

# Scalable Computing: Practice and Experience

---

Scientific International Journal  
for Parallel and Distributed Computing

ISSN: 1895-1767



Volume 16(4)

December 2015

---

EDITOR-IN-CHIEF

**Dana Petcu**

Computer Science Department  
West University of Timisoara  
and Institute e-Austria Timisoara  
B-dul Vasile Parvan 4, 300223  
Timisoara, Romania  
petcu@info.uvt.ro

MANAGING AND  
TEXNICAL EDITOR

**Marc Eduard Frîncu**

Computer Science Department  
West University of Timisoara  
and Institute e-Austria Timisoara  
B-dul Vasile Parvan 4, 300223  
Timisoara, Romania  
mfrincu@info.uvt.ro

BOOK REVIEW EDITOR

**Shahram Rahimi**

Department of Computer Science  
Southern Illinois University  
Mailcode 4511, Carbondale  
Illinois 62901-4511  
rahimi@cs.siu.edu

SOFTWARE REVIEW EDITOR

**Hong Shen**

School of Computer Science  
The University of Adelaide  
Adelaide, SA 5005  
Australia  
hong@cs.adelaide.edu.au

**Domenico Talia**

DEIS  
University of Calabria  
Via P. Bucci 41c  
87036 Rende, Italy  
talia@deis.unical.it

EDITORIAL BOARD

**Peter Arbenz**, Swiss Federal Institute of Technology, Zürich,  
arbenz@inf.ethz.ch

**Dorothy Bollman**, University of Puerto Rico,  
bollman@cs.uprm.edu

**Luigi Brugnano**, Università di Firenze,  
brugnano@math.unifi.it

**Giacomo Cabri**, University of Modena and Reggio Emilia,  
giacomo.cabri@unimore.it

**Bogdan Czejdo**, Fayetteville State University,  
bczejdo@uncfsu.edu

**Frederic Desprez**, LIP ENS Lyon, frederic.desprez@inria.fr

**Yakov Fet**, Novosibirsk Computing Center, fet@ssd.sscs.ru

**Giancarlo Fortino**, University of Calabria,  
g.fortino@unical.it

**Andrzej Goscinski**, Deakin University, ang@deakin.edu.au

**Frederic Loulergue**, Orleans University,  
frederic.loulergue@univ-orleans.fr

**Thomas Ludwig**, German Climate Computing Center and Uni-  
versity of Hamburg, t.ludwig@computer.org

**Svetozar D. Margenov**, Institute for Parallel Processing and  
Bulgarian Academy of Science, margenov@parallel.bas.bg

**Viorel Negru**, West University of Timisoara,  
vnegru@info.uvt.ro

**Moussa Ouedraogo**, CRP Henri Tudor Luxembourg,  
moussa.ouedraogo@tudor.lu

**Marcin Paprzycki**, Systems Research Institute of the Polish  
Academy of Sciences, marcin.paprzycki@ibspan.waw.pl

**Roman Trobec**, Jozef Stefan Institute, roman.trobec@ijs.si

**Marian Vajtersic**, University of Salzburg,  
marian@cosy.sbg.ac.at

**Lonnie R. Welch**, Ohio University, welch@ohio.edu

**Janusz Zalewski**, Florida Gulf Coast University,  
zalewski@fgcu.edu

---

SUBSCRIPTION INFORMATION: please visit <http://www.scpe.org>

# Scalable Computing: Practice and Experience

Volume 16, Number 4, December 2015

---

## TABLE OF CONTENTS

### SPECIAL ISSUE ON PRINCIPLES AND PRACTICES IN MULTI-AGENT SYSTEMS:

<b>Introduction to the Special Issue</b>	iii
<b>Combining PosoMAS Method Content with Scrum: Agile Software Engineering for Open Self-Organising Systems</b>	333
<i>Jan-Philipp Steghöfer, Hella Seebach, Benedikt Eberhardinger, Michael Hübschmann and Wolfgang Reif</i>	
<b>Modelling Dynamic Normative Understanding in Agent Societies</b>	355
<i>Christopher Konstantin Frantz, Martin K. Purvis, Bastin Tony Roy Savarimuthu and Mariusz Nowostawski</i>	
<b>A Multi-Agent Approach for Trust-based Service Discovery and Selection in Social Networks</b>	381
<i>Amine Louati, Joyce El Haddad and Suzanne Pinson</i>	
<b>Multi-Objective Distributed Constraint Optimization using Semi-Rings</b>	403
<i>Graham Billiau, Chee Fon Chang and Aditya Ghose</i>	

### REGULAR PAPERS:

<b>Scaling Beyond One Rack and Sizing of Hadoop Platform</b>	423
<i>Wiesława Litke and Marcin Budka</i>	
<b>Energy Efficiency of Parallel Multicore Programs</b>	437
<i>Davor Davidović, Matjaž Depolli, Tomislav Lipić, Karolj Skala and Roman Trobec</i>	
<b>An Energy-Aware Algorithm for Large Scale Foraging Systems</b>	449
<i>Ouarda Zedadra, Hamid Seridi, Nicolas Jouandeau and Giancarlo Fortino</i>	

### OVERVIEW PAPERS:

<b>On Processing Extreme Data</b>	467
<i>Dana Petcu, Gabriel Iuhasz, Daniel Pop, Domenico Talia, Jesus Carretero, Radu Prodan, Thomas Fahringer, Ivan Grasso, Ramón Doallo, María J. Martín, Basilio B. Fraguera, Roman Trobec, Matjaž Depolli, Francisco Almeida Rodriguez, Francisco de Sande, Georges Da Costa, Jean-Marc Pierson, Stergios Anastasiadis, Aristides Bartzokas, Christos Lolis, Pedro Gonçalves, Fabrice Brito, Nick Brown</i>	





## INTRODUCTION TO THE SPECIAL ISSUE ON PRINCIPLES AND PRACTICES IN MULTI-AGENT SYSTEMS

Agent-based Computing addresses the challenges in managing distributed computing systems and networks through monitoring, communication, consensus-based decision-making and coordinated actuation. As a result, intelligent agents and multi-agent systems have demonstrated the capability to use intelligence, knowledge representation and reasoning, and other social metaphors like 'trust', 'game' and 'institution', to not only address real-world problems in a human-like way but to transcend human performance. This has had a transformative impact on many application domains, particularly e-commerce, but also on planning, logistics, manufacturing, robotics, decision support, transportation, entertainment, emergency relief & disaster management, and data mining & analytics. As one of the largest and still growing research fields of Computer Science, agent-based computing today remains a unique enabler of inter-, multi- and trans-disciplinary research.

This special issue provides a selection of papers concerning the state-of-the-art research in multi-agent systems. Although the idea was initiated at 17th International Conference on Principles and Practice of Multi-Agent Systems, an open call allowed any researcher working on related topics to submit a paper for review.

This special issue features four articles:

- The article entitled "Combining PosoMAS Method Content with Scrum: Agile Software Engineering for Open Self-Organising Systems" by Jan-Philipp Steghöfer, Hella Seebach, Benedikt Eberhardinger, Michael Hübschmann, Wolfgang Reif proposes PosoMAS-Scrum, an agile agent-oriented software engineering process for developing large-scale open self-organising systems. The authors also demonstrate how this method can be applied in a development effort and compare it with existing approaches.
- The article entitled "Modelling Dynamic Normative Understanding in Agent Societies" by Christopher Konstantin Frantz, Martin K. Purvis, Bastin Tony Roy Savarimuthu, Mariusz Nowostawski proposes an approach to build up normative understanding from the bottom up without using any prior knowledge. Their approach combines both existing institution representations (the structure) with a norm identification process
- The article entitled "A Multi-Agent Approach for Trust-based Service Discovery and Selection in Social Networks" by Amine Louati, Joyce El Haddad, Suzanne Pinson proposes an approach to use multi-agent systems to model the service discovery and selection process. The authors present a trust model for social networks which supports agents in determining trustworthy service providers and allows agents to reason about trust in their distributed decision-making process.
- The article entitled "Multi-Objective Distributed Constraint Optimization using Semi-Rings" by Graham Billiau, Chee Fon Chang and Aditya Ghose proposes an extended Support Based Distributed Optimization algorithm to support Multi-Objective Distributed Constraint Optimization problem. The authors also demonstrate that by building a new DCOP definition using an idempotent semiring to measure the cost/utility of a solution, this approach is able to solve multiple objectives without a total pre-order over the set of solutions.

We would like to thank the editorial board of SCPE for the chance of arranging this special issue, and all the reviewers for their hard work.

Hoa Khanh Dam, Jeremy Pitt, Guido Governatori, Takayuki Ito, Yang Xu.





## COMBINING POSOMAS METHOD CONTENT WITH SCRUM: AGILE SOFTWARE ENGINEERING FOR OPEN SELF-ORGANISING SYSTEMS

JAN-PHILIPP STEGHÖFER\* AND HELLA SEEBACH, BENEDIKT EBERHARDINGER, MICHAEL HÜBSCHMANN, WOLFGANG REIF†

**Abstract.** In this paper we discuss how to combine the method content from PosoMAS, the Process for open, self-organising Multi-Agent Systems, with the agile iterative-incremental life cycle of Scrum. The result is an agile software engineering methodology tailored to open self-organising systems. We show how the methodology has been applied in a development project and discuss the lessons learned. Finally, we compare the Scrum version of PosoMAS to other agile agent-oriented software engineering methodologies and address the selection of a suitable process.

**Key words:** Agent-oriented Software Engineering, Self-Organising Systems, Software Engineering Processes

**AMS subject classifications.** 68T42, 68N30

**1. Challenges of Agent-oriented Software Engineering Processes.** The fact that multi-agent systems (MAS) and self-organisation have not yet arrived in the software engineering mainstream is a pity, especially since the potential of these technologies with regard to robustness, adaptivity, and scalability has been demonstrated (see, e.g., [22, 27, 28]). There are a number of reasons for this situation, not the least of which is that discussion on these topics takes place mostly in academia and very rarely involves actual software companies. Another reason might be that there is a plethora of approaches, often requiring specialised modelling tools and languages, and in general ways of thinking about the systems under construction different from “traditional” software engineering, or depending on a certain runtime infrastructure.

Interestingly, these “traditional” processes make no or very little assumption about which kind of software is developed with them. They are agnostic of the framework used, the tool, modelling languages, programming paradigm, and deployment platform. A process like OpenUP [20] is just as useful in building a game for an Android phone than it is for building a scientific application. Arguably, this agnosticism is possible due to the fact that the guidance provided by these processes is on such an abstract level. It also considers the management of the project much more than the actual technical execution. On the other hand, these processes had a long time to mature and grow with constant feedback from industry and academia.

Agent-oriented methodologies in general follow a different philosophy: instead of focusing on issues of project management and providing structure for the different technical activities, they describe the way to a technical solution in great detail. They are thus much more specific to the domain and often to a certain architecture, tool, or framework. Of course, this takes a lot of the guesswork out of building a multi-agent system and especially allows inexperienced developers to come up with a solution that uses the somewhat unique or at least unusual paradigm for a developer familiar with object-oriented programming.

While this philosophy doubtlessly has its merits, it also prevents using the method content developed in the different approaches to be interchanged and hinders the tailoring of the processes. If we look at the method content of INGENIAS [18] or ASPECS [10], e.g., we can see that many of the activities are specific to the meta-model used and are not compatible with other processes using no or a different meta-model. This is arguably an impediment to cross-fertilisation and convergence towards common standards in the community.

PosoMAS has adopted a different philosophy. As outlined in our previous paper on the process [40] and in Sect. 2, it has been created to respond to a number of requirements, including extensibility and customisability as well as independence from architectures or tools. By following the example of OpenUP and defining independent practices, the method content is highly adaptable, amenable to tailoring, and can be re-used in different contexts. We therefore consider PosoMAS to be more of a collection of reusable assets than a process in and of itself.

\*Chalmers Technical University — University of Gothenburg, Software Engineering Division, Gothenburg, Sweden ([jan-philipp.steghofer@cse.gu.se](mailto:jan-philipp.steghofer@cse.gu.se))

†Augsburg University, Institute for Software & Systems Engineering, Augsburg, Germany ([firstname.lastname@informatik.uni-augsburg.de](mailto:{firstname.lastname}@informatik.uni-augsburg.de), [michaelhuebschmann@hotmail.de](mailto:michaelhuebschmann@hotmail.de))

The management aspects of the process are provided by a framework process and lifecycle. In this regard, PosoMAS has similarities to O-MaSE [14] but does not enforce the use of a specific tool for process tailoring and modelling.

At the same time, PosoMAS' technical practices address the needs of a specific subset of MAS that have so far been somewhat neglected. If a system has to be open and has to exhibit self-organisation, principled software engineering techniques become even more important. For instance, in such cases, the benevolence assumption, i.e., the assumption that the individual agents contribute to reaching an overall system goal, can no longer be maintained. The dynamics of self-organisation and the potential negative emergent effects are thus coupled with self-interested, erratic, and even potentially malevolent agents that still have to be integrated in the system. Examples for domains that exhibit such effects are energy management [41] and open grid computing [6]. Arguably, some of the practices dealing with the specifics of the system class introduce specific modelling elements or suggest certain notation — but by no means is the developer forced to adopt these practices or to comply to a meta-model for the entire project.

Our previous scientific contributions (refer to, e.g., [41, 43, 17, 42]) have dealt with these issues without being embedded in a methodology for the principled design of such systems. While conceptual and algorithmic solutions for such problems are often the focus of research, they are rarely embedded in a methodology for the principled design of such systems, a shortcoming that we aim to remedy with the PosoMAS method content.

This paper combines the method content of PosoMAS with the project management practices of Scrum and the Agile System Development life-cycle (SDLC) that embeds Scrum sprints in an iterative framework. It introduces the requirements that motivate the development of PosoMAS (Sect. 2), outlines the most important practices of PosoMAS (Sect. 3), shows how they are embedded in the life cycle (Sect. 4) and demonstrates the way the resulting process can be applied in the development of a MAS (Sect. 5). We also put our work in the context of other agent-oriented software engineering approaches and in particular compare the PosoMAS method content and its application to Scrum with Prometheus [32], ASPECS, and with the Scrum version of INGENIAS in Sect. 6. Finally, we discuss benefits, limitations, and lessons learned in our development efforts (Sect. 7).

The present work extends our previous paper on PosoMAS [40] in several ways: it offers a guideline of how the method content can be combined with different life cycles and project management styles based on situational method engineering and exemplifies the guideline with Scrum; it provides an example showing how the process can be applied in practice; and it discusses the similarities and differences with INGENIAS-Scrum, a process that has not been part of the analysis before. Since the format of a research paper is insufficient to describe a comprehensive methodology in full detail, the reader is advised to peruse the detailed process description at <http://posomas.isse.de>. The website also offers the method content for use in the EPF Composer and additional information on the comparison of AOSE processes.

**2. Requirements for a Process for Large-Scale Open Self-Organising Systems.** There are two main themes that define the requirements we have identified for the design of PosoMAS: the ability to use the method as readily as standard object-oriented methodologies and the ability to deal with characteristics of open self-organising systems. The individual requirements listed below address those themes and are the basis for the solution that has been developed. The first four requirements address the need to create an open, flexible, and extensible process. As discussed in Sect. 1 and 6, other MAS methodologies lack this flexibility at this point. The requirements listed here are the result of an analysis of existing agent-oriented software engineering approaches and reflections of our own experience with processes and engineering of self-organising system (see, e.g., [38, 43]). While they have guided the development of PosoMAS, we consider them work in progress. As we gain more experience and confidence in applying the process, we expect to understand the needs better and consequently refine these requirements.

R1: Accessibility to “traditional” software engineers. We strive to create a process that incorporates elements of agent-oriented software engineering approaches without alienating software engineers that have previously worked with “traditional” systems, such as service-oriented or regular object-oriented systems. One of the driving factors for this requirement is to allow designers with a software engineering background to use tools that they know and understand and not overwhelm them with agent-oriented specifics from the beginning. This means, e.g., that the process allows the use of any notation, including standards such as UML, and



thus standard modelling tools. It also means that the process has to be as adaptable and customisable as methodologies used for object-oriented software engineering.

R2: Architecture and tool agnostic The internal architecture of the agents (such as BDI) should play a little role in the high-level design part of the process as the implementation platform on which the agent system will run. Object-oriented methodologies such as OpenUP or the V-Model are defined on a level of abstraction that enables this agnosticism. The methodology should be applicable regardless of the concrete architecture and implementation platform used to allow applicability to a wide array of scenarios.

R3: Level of detail. The process must contain support for all relevant activities in the design process. It must make clear which knowledge it assumes the designer to have and point to additional material that can be used to extend the level of understanding. The methodology must contain sufficient guidance and templates for the artefacts that must be created. The methodology should also cover the entire life cycle of a software engineering methodology, including deployment of the system.

R4: Extensibility and customisability. The methodology must be extendible and it must be possible to combine it with different process models and to customise it for specific situations as part of a situational method engineering process. This means that it must be possible to use the method chunks put forward in an agile context (e.g., by using it in a specialised Scrum process as described in this paper) as well as in a heavy-weight context (e.g., using the still pervasive waterfall method), or to embed it in the risk/value life cycle provided by the OpenUP (as described in [40]). It must also be possible to apply situational method engineering [21] to the process to come up with a methodology suitable for the project, the team, and the environment it will be used in.

The second set of requirements deals more directly with the needs present in open self-organising systems and address their openness, their scale, and the aspect of self-organisation.

R5: Clear separation of different architecture domains. Especially in open systems, development of the individual agents might not be in the hand of the system designer. In the example of an autonomous power grid [41], the agents representing the power plants are not designed by the same people that design their interaction in the system and set up the infrastructure. Instead, the system designer has to define interfaces, data models, and interactions so that other development teams know how the agents should behave in the system, interact with other agents, and with the system as a whole. Even if the system and the individual agents are implemented by the same company, different teams within the organisation can be responsible for the implementations.

R6: Special focus on interactions between agents and agent organisations. The dynamics of an open self-organising multi-agent system are defined by the interactions between agents within organisations under uncertainty. The behaviour of the individual agent within an organisation plays an important role for the fitness for purpose of the organisation and of its ability to reach its goal within the system. Organisations and their structure also play an important role in terms of the scalability of the final system. Different system structures of organisations—among them hierarchical ones—must be supported by the design activities as well as requirements elicitation and analysis.

R7: Top-down design vs. bottom-up functionality. While a systems engineering methodology is necessarily top-down, starting from overall system goals, self-organisation processes and coordinated processes within multi-agent systems provide this striven for functionality in a bottom-up way [43]. A methodology that is suitable for self-organising systems must take this change of perspective into account and provide appropriate tools for the design, test, and implementation of bottom-up processes.

In addition to these requirements, we adopt the principles of standard software engineering methods such as OpenUP, that promote reuse, evolutionary design, shared vision, and others. These principles are documented, e.g., in [25] for the Rational Unified Process, a commercial software engineering methodology that introduced many of the features that are present in modern processes such as OpenUP.

**3. PosoMAS in a Nutshell.** The technical practices for PosoMAS, compiled in a *practice library*, cover the disciplines requirements, architecture, and development. Testing and deployment are the focus of ongoing work (see, e.g., [16]) since both disciplines are very important in MAS and have not been dealt with sufficiently

Table 3.1: Simplified description of important process modelling concepts.

Concept	Description
Practice	A collection of method content that addresses a specific issue or allows to achieve a specific goal. Used by EPF (and PosoMAS) to structure method content. Practices will be printed in <b>bold font</b> in the following.
Task	Describes a unit of work. A task can create or transform a work product and can be assigned to a certain role. It can contain individual steps that have to be performed as part of carrying out the task. Guidances can be provided, e.g., to give guidelines or checklists. Tasks can be subsumed in activities. They will be printed in <i>italics</i> in the following.
Activity	Groups other elements such as tasks, milestones, or other activities. The order of elements within the activity is denoted as the <i>work breakdown structure</i> and is established by defining predecessors for the elements in the structure. Activities will be printed in <b><i>bold italics</i></b> .
Work Product	Documents, models, code, or other tangible elements that are produced, consumed, and modified by tasks. Responsibilities for work products can be assigned to roles.
Work Product Slot	Define an abstract work product that can be instantiated with a concrete one. Play an important role in the definition of work products that are exchanged between practices. As an example, requirements can be captured in a number of concrete work products, e.g., in a use-case model, in user stories, or in a systems goal model. Using the more generic work product slot [Requirements Model] allows specifying that requirements are used by a practice but does not prescribe which kind of requirements are necessary. Work product slots are fulfilled with concrete work products in the assembly of the process. To differentiate a work product slot from a work product, the former is always enclosed in square brackets.
Role	Denotes an individual or a group of individuals with a certain set of skills, competencies, and responsibilities required in the process. Different roles can be filled by different people during the process and an individual can fill several roles if required.
Process	Defines the sequence of activities and tasks, phases, and milestones to get to the final product. Within a process, concrete roles, tasks, work products, etc. are defined. A tailored process for a specific project is modelled as a <i>Delivery Process</i> . In EPF, partial processes are captured in <i>Capability Patterns</i> .
Guidance	Provides additional information about the elements in the method content. Different kinds of guidances are possible: guidelines, templates, checklists, tool mentors, supporting materials, reports, concepts, examples, and others.

as of yet. It is possible, however, to use practices from other processes for these issues as illustrated in Sect. 4.2. All PosoMAS method content is specified using SPEM<sup>1</sup>. The most important SPEM concepts used in the following are detailed in Table 3.1. Furthermore, PosoMAS makes use of EPF<sup>2</sup>. EPF provides a common baseline for process development by providing a usable version of SPEM as well as a tool to define processes, the EPF Composer. In addition, it provides process content in the form of method libraries, such as a model of OpenUP. The EPF method libraries introduce a number of commonly used concepts, such as pre-defined roles for developers and architects. PosoMAS makes use of these common concepts instead of re-defining them, extends them if necessary and adds many specific elements that are not covered in the standard libraries.

<sup>1</sup>Software & Systems Process Engineering Metamodel (<http://www.omg.org/spec/SPEM/2.0/>), defined by the Object Management Group (OMG).

<sup>2</sup>Eclipse Process Framework (EPF): <http://epf.eclipse.org/>

**3.1. Rationale and Structure of PosoMAS.** We adopt the notion of situational method engineering [21]: while we define method content (i.e., tasks, activities, work products, guidance, etc.) and in some aspect also the order in which this method content should be applied, the content is formulated in such a way that a process engineer can use it to construct a specific instance of a process tailored to the development effort at hand. This means that the method content (collected in *practices* that address specific needs and purposes) is combined with a specific life cycle and selections are made, how the content is used, who is going to fill the roles, and which work products are created and used. The creation of a specific process instance from existing method content is known as *process tailoring*. Allowing this flexibility and adaptability addresses requirement R4: Extensibility and customisability.

The practices that contain the method content in PosoMAS introduce techniques for the principled design of individual agents, organisations, their interactions, as well as the overall system and the environment. The categorisation of these techniques is an important aspect of the design of the process and addresses the requirement for R5: Clear separation of different architecture domains:

**Agent Architecture:** the design of the *individual agents*, separate for each type of agent relevant in the system.

**Agent Organisation:** the specification of *organisational paradigms* that will structure the agent population at runtime.

**Agent Interaction:** the definition of *interfaces and protocols* used by agents to exchange information, delegate control, and change their organisational structure.

**System Architecture:** the design of the *entire system*, including the relationship between the different types of agents, the supporting infrastructure, and external components as well as the environment.

The PosoMAS method content is connected by the use of work product slots to exchange information between the activities and tasks specified for each practice. As an example for exchange within PosoMAS, consider **Practice: Agent Environment Design**. It contains tasks that describe how a work product slot [Requirements Model] is used as the basis for identification of the necessary infrastructure to support the MAS under construction (e.g., external services that must be used, relevant actors that require an interface to the system). The identified infrastructure, which interfaces are necessary, and what these interfaces look like is captured in the Multi-Agent System Architecture work product. This work product is used by other practices, such as **Practice: Evolutionary Agent Design** or **Practice: Organisational Design** as an input for their own design decisions. The flow of work products thus defines how the practices and activities within PosoMAS are connected.

These work products are also the interface to method content from other processes. INGENIAS, e.g., offers method content for the design of BDI agents. If a concrete process instance for a specific project wants to make use of this method content, it can, e.g., use the activity *Generate Agent Model* [18] from INGENIAS. This activity creates a concrete instantiation of the work product slot [Agent Architecture], as defined in PosoMAS. Since all practices in PosoMAS are independent of the concrete instantiation of this work product slot, but rather require abstract properties (the instantiation should be a description of the internal architecture of an agent), the content from different processes can be readily combined. In this way, the work product slots act comparably to interfaces in object-oriented programming.

PosoMAS does not prescribe a specific modelling language or a certain tool chain. Instead, it suggests the use of UML and gives the developers support in that by providing a corresponding UML profile for the definition of agent concepts. This addresses R1: Accessibility to “traditional” software engineers and R2: Architecture and tool agnostic.

**3.2. Overview of PosoMAS practices.** As PosoMAS is targeted at open systems, the architectural tasks are aimed at providing standardisation, separation of concerns, and interoperability. The applicability to a wide range of target systems has also been a concern. Therefore, even though some content of the practices is specific to open self-organising MAS, they do not require the use of a specific meta-model or agent architecture, again addressing R2: Architecture and tool agnostic. The concrete practices are also tailored to address R6: Special focus on interactions between agents and agent organisations, a requirement that has greatly influenced the practice **Practice: Organisational Design**, and R7: Top-down design vs. bottom-up functionality which is evident, e.g., in **Practice: Goal-driven Requirements Elicitation** and the interplay between **Practice:**

**Evolutionary Agent Design and Practice: Organisational Design.** The practice library provides the practices described briefly below. Missing from the content here is **Practice: Trust-based Interaction Design**, as it has not been applied in the case study. It encompasses the design and implementation of a trust and reputation system to deal with agents for which the benevolence assumption does not hold. Please note that rather than stating the concrete outputs of the practices below, we state the work product slots that the outputs can fill, in order to show how the practices can be combined.

Practice: **Goal-driven Requirements Elicitation**  
 Description: Operationalises the technique for requirements elicitation based on KAOS [26] and the work of Cheng et al. [9]. The purpose of this practise is to provide an iterative process to successively refine the goal model until a complete model of the system requirements is gained. Beside the system goal model, a conceptual domain model as well as a glossary of the domain are outputs of this practice. The approach is ideally suited for adaptive systems since uncertainties and their mitigation can be directly modelled in the requirements. This allows the stakeholders to reason about countermeasures and identify risks early on. The practice is easily embedded in iterative-incremental processes. System goals can be elaborated in different iterations, with a preference to elaborate those first that have the greatest potential impact and risk. Guidelines detail the application of the practice in an agile environment and how to capture process support requirements. We demonstrate in Sect. 5 how this practice can be integrated with the backlogs used in Scrum.

Main Input: Vision Document  
 Main Output: Requirements Model

Practice: **Pattern-driven MAS Design**  
 Description: Provides guidance to design a MAS based on existing architectural, behavioural, and interaction patterns and reference architectures. These three types of patterns correspond to the system architecture, agent architecture, and agent interaction areas. The practice enables reuse, avoids making mistakes twice, and allows tapping into the knowledge that has been created elsewhere for a cleaner, leaner, and more flexible design.

Main Input: [Agent Architecture], [Interaction Model], [Multi-Agent System Architecture], [Requirements Model]  
 Main Output: [Agent Architecture], [Interaction Model], [Multi-Agent System Architecture], Architectural Style Notebook

Practice: **Evolutionary Agent Design**  
 Description: Describes an approach to design agents and their architecture in an evolutionary way that enhances the design over time while requirements become clearer and development progresses. During the development process, the agent types, their capabilities and behaviour, their internal architecture, and their interactions become clearer as the requirements mature and development progresses towards a shippable build. To allow the product to mature this way, the design of the agents has to adapt to new knowledge continuously and become more specific by refinement when necessary and incorporating changes in the requirements or the system environment.

Main Input: [Requirements Model]  
 Main Output: [Agent Architecture], [Interaction Model], [Multi-Agent System Architecture]

- Practice: **Agent Environment Design**  
 Description: Outlines how the system the agents are embedded in is designed and how the agents interact with it. This pertains to the *System Architecture* aspect. A MAS not only consists of autonomous agents but also incorporates a multitude of additional often grounded infrastructure, external actors, interfaces, hardware, and environmental factors. These can have a significant impact on the overall system design and should be regarded early on. The practice provides tasks to identify these factors and incorporate them in the design of the overall system. This includes the identification and design of necessary interfaces between the agents and to external components in the system's environment as well as the identification of uncertainty factors in the environment.
- Main Input: [Interaction Model], [Requirements Model]  
 Main Output: [Multi-Agent System Architecture], [System Environment Description], [Interaction Model]
- Practice: **Organisational Design**  
 Description: Describes the design of the organisation [23] the agents will interact in, thus addressing the *Agent Organisation* aspect. Multi-agent systems with many interacting agents require a form of structure or organisation imposed on the population. Sometimes, this structure is permanent, such as a hierarchy that determines the delegation of control and propagation of information, or transient, such as a coalition in which agents interact until a certain common goal is reached. The system designer has to decide which organisations are suitable for the system to reach the stated goals and implement mechanisms that allow the formation of these organisational structures at runtime. If this process is driven from within the system, "self-organisation" is present.
- Main Input: [Multi-Agent System Architecture], [Requirements Model]  
 Main Output: [Agent Organisation Definition]  
 Guidance: Bryan Horling and Victor Lesser – A Survey of Multi-Agent Organizational Paradigms (Whitepaper) [23]
- Practice: **Model-driven Observer Synthesis**  
 Description: Describes how observer implementations can be synthesized from constraints specified in the requirements documents as described in [17]. In adaptive systems, it is necessary to observe the system and react if the system enters an undesirable state or shows unwanted behaviour. For this purpose, feedback loops, operationalised as observer/controllers can be employed [36]. Therefore, this practice supports the developer on the automatic transformation of specified constraints into observers that monitor these constraints at runtime. A prerequisite of this practice is that constraints have been captured during requirements analysis. The process can be repeated after the requirements or the domain model have changed, according to a model-driven design (MDD) approach. Changed parts of the system models and implementation will be re-generated while existing models and code are preserved.
- Main Input: [Agent Architecture], [Interaction Model], [Multi-Agent System Architecture], [Requirements Model]  
 Main Output: Observation Model, Implementation  
 Guidance: How to adopt the Model-driven Observer Synthesis practice (Roadmap), Observation Model (Concept), Observer/Controller Architecture (Concept), Benedikt Eberhardinger et al. – Model-driven Synthesis of Monitoring Infrastructure for Reliable Adaptive Multi-Agent Systems (Whitepaper) [17]

Each practice is defined by an appropriate guidance in EPF that states the purpose of the practice, gives a description, and provides a brief instruction on how the elements of the practice relate to each other and in which order they should be read. The practice usually references a roadmap that describes how a novice should approach adopting this practice, a list of key concepts and white papers, and a set of helpful material in the form of guidances, thus addressing the requirement to have the necessary R3: Level of Detail. A practice also

takes one or several work products (or work product slots) as inputs and outputs.

For use within a process, tasks from different practices are combined in activities. These activities are often addressing a common theme. For PosoMAS-Scrum, e.g., the activity Develop Agent Architecture combines tasks from **Practice: Pattern-driven MAS Design** and **Practice: Evolutionary Agent Design**. Activities and tasks can in turn be combined in capability patterns (nested activities, so to speak) such as Design Architecture Components. These patterns are then arranged within the lifecycle as demonstrated in Sect. 4.2.

The detailed practice descriptions and the models for use in EPF are available at <http://posomas.isse.de>. We thus provide a repository for method content and make reusable assets available for combination with method content from other processes, fulfilling the appeal of the IEEE FIPA Design Process Documentation and Fragmentation Working Group and many authors (e.g., [39, 11]).

**4. The PosoMAS-Scrum Life Cycle.** The process life cycle determines the progression of a product under development in the context of the process, the stakeholders, and the environment. A well-defined life cycle provides guidance w.r.t. the order of activities the Scrum Team has to perform, the project milestones and deliverables, and the progress of the product. The advancement of a product development effort can thus be measured based on the planned and the actual progress within the life cycle. Scrum is an example of a light-weight process framework that embraces the Agile Manifesto [5]. It consists of a number of rules that prescribe how roles, events, and artefacts have to be combined for a *Scrum Team* to manage a complex software development project and create value for the customer [37]. Within these boundaries it is possible to apply custom development practices. Scrum has been modelled in the EPF Composer by Mountain Goat Software<sup>3</sup> and a method plugin containing the method content is available. The customisation is based on a significant extension of this method content.

**4.1. Structure of Scrum.** At the core of Scrum is the insight that it is impossible to conclusively define requirements and that it is therefore necessary to include the client in all phases of the development and be able to react to changes in the requirements quickly. A change request is thus not an exceptional event but something rather normal, making it very easy to incorporate changes into the development process. The decisions of the project team are always based on what is currently known about the project, a principle called *empiricism* [37]. This makes it necessary to form decisions transparent for the stakeholders, inspect past decisions based on new data regularly, and adapt if the circumstances have changed.

The other principle is the focus on a self-organising Scrum Team. While different roles still exist, Scrum promotes the notion that different members of the Scrum Team assume these roles of their own accord. The Scrum Team decides internally how the work is split among the team members and is involved in all important decisions, including assessment of the effort required to perform certain tasks. A *Scrum Master* is designated in each team who ensures that the Scrum rules are adhered to, but also acts as a spokesperson for the Scrum Team and coordinates communication with external stakeholders. Importantly, a *Product Owner*, ideally a representative of the client with the authority to make decisions about the product and embedded in the Scrum Team, defines the requirements and prioritises them by importance. She is also available to the Scrum Team to answer questions and relay issues that come up during development to the client organisations. The Product Owner has, however, no authority over the Scrum Team [37].

The most important communication device between the Scrum Team and the Product Owner is the *Product Backlog*. It contains all currently known and open requirements for the product, including features and non-functional requirements [37]. While Scrum does not prescribe the form in which requirements are represented in the product backlog, they are often captured in the form of *user stories* (see, e.g., [31]). A user story describes *who* wants to achieve *what* and *why*. Regardless of the form the requirements take, they are ordered in the backlog according to their risk, customer value, complexity, or any other criteria the Product Owner deems reasonable.

The Scrum Team estimates the effort required to realise the requirements. As part of a “grooming” process, the Product Owner and the Scrum Team together refine the requirements, re-order them and adapt estimates. As part of a *Sprint Planning Meeting*, the requirements that will be tackled in the next development iteration —

<sup>3</sup>The corresponding content can be found in a human-readable form at <http://epf.eclipse.org/wikis/scrum/>, made available under the Eclipse Public License v1.0.

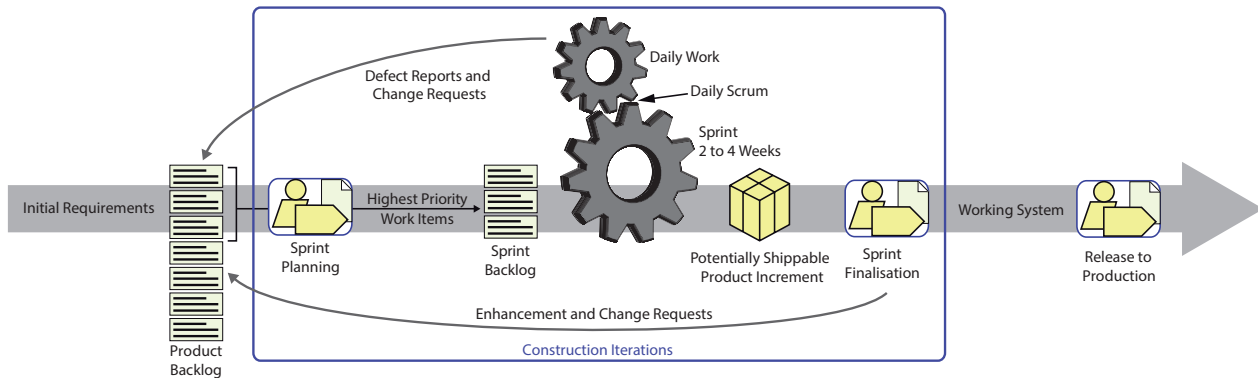

Fig. 4.1: Ambler et al.’s Agile System Development life-cycle (SDLC) [3] as used for PosoMAS-Scrum. SDLC is an extension of the standard Scrum sprint life cycle with iterations and consideration of preparatory as well as release activities. Initial requirements are captured in a *Product Backlog*. An iteration consists of *Sprint Planning*, in which the backlog is prioritised and the work items for the sprint are selected. The sprint itself consists of small increments of *Daily Work*, initiated by a *Daily Scrum*. After the 2 to 4 weeks of the sprint are completed, a *Potentially Shippable Product Increment* has been created. The *Sprint Review*, which together with the *Sprint Retrospective* constitutes the *Sprint Finalisation*, gives all stakeholders the opportunity for feedback. After construction is complete, the working system is released to production. The product backlog can be changed or augmented by the stakeholders at any time during or after a sprint.

called a *Sprint*—are picked and transferred into the *Sprint Backlog*. During the sprint, the Scrum Team creates a complete *Potentially Shippable Product Increment* that realises the picked requirements (the *Sprint Goal*) over a time horizon of a month. The Product Owner can cancel the sprint if the Sprint Goal no longer aligns with the client organisation goals.

During a sprint, daily structured meetings are performed to further communicate between the Scrum Team members and to assess the progress of the sprint. These *Daily Scrums*—also called *Standup Meetings* since they are usually held with all participants standing—are 15-minute meetings in which the progress, the planned work, and any issues are discussed [37]. In larger projects, a *Scrum of Scrums* can be used with similar rules to coordinate between different Scrum Teams. Scrum promotes co-location of all team-members, meaning that it is easy to communicate directly with other members of the team, to exchange information, and to help each other with technical difficulties. When the sprint is concluded, the Scrum Team presents the Potentially Shippable Product Increment to the Product Owner during the *Sprint Review* and fulfilment of the Sprint Goal as well as future requirements and necessary changes are discussed. Finally, the *Sprint Retrospective* gives the Scrum Team a chance to reflect on the last sprint and discuss possible improvements.

**4.2. Embedding PosoMAS practices in Scrum.** The description above does not include concrete development practices. Indeed, Scrum is seen as a framework, defining rules and an environment, in which concrete development practices can be applied. Scrum does not per se include a process life-cycle in which the method content can be embedded. It introduces the notion of a sprint but there are no defined places for the preparatory and release work. Therefore, we use a variant of the “Agile System Development life-cycle (SDLC)” [3], that embeds the elements Scrum provides. It contains a framework for the individual sprints, including project setup and initial requirements and deployment and operation. Sprints are embedded in iterations which contain sprint planning and review. The version of the life-cycle used here is shown in Fig. 4.1.

The PosoMAS practices are used within a sprint embedded within an iteration of the SDLC. An iteration, depicted in Fig. 4.2 embeds the activities defined in the PosoMAS practices library in a Scrum sprint. The Scrum Team decides which activities, sub-activities and tasks it has to tackle each given day. This gives them a flexible structure within which to work. All guidances, work products, and other method content defined in the PosoMAS practices are at their disposal. In general, Scrum puts less focus on documentation. Therefore,

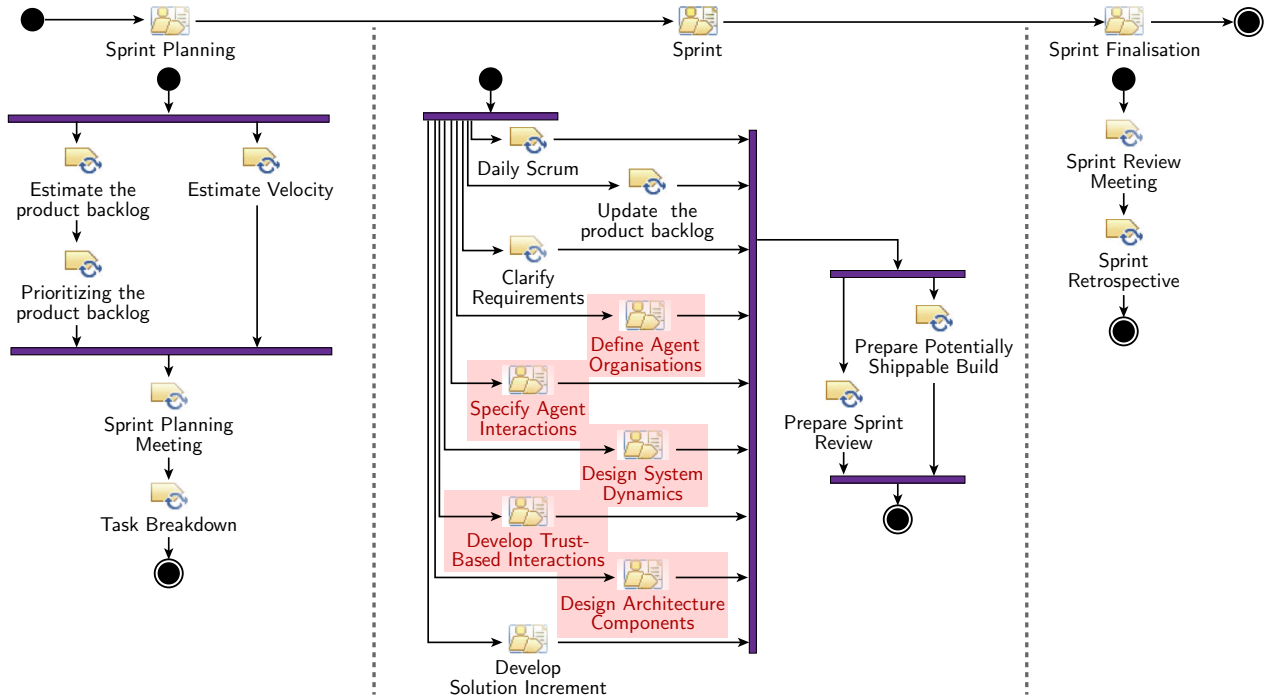

Fig. 4.2: Structure of an iteration in PosoMAS-Scrum, combining method content from PosoMAS, Scrum, and OpenUP. An iteration is started by preparatory activities to produce a new version of the product backlog and select requirements for the sprint. During the sprint, the activities from PosoMAS (highlighted) are performed as required during the daily work. The sprint ends after a certain time or when all backlog items have been tackled with a Sprint Review and a Sprint Retrospective.

a Scrum Team can decide to create less models or combine models suggested by PosoMAS activities and tasks. Since most of the management documents have been defined in the OpenUP and are not present in the PosoMAS-Scrum method configuration, no additional customisation has to be performed in this regard.

PosoMAS adds most of its method content in the design activities and replaces use cases with system goals as the main model to capture requirements. Therefore, PosoMAS-Scrum has requirements engineering activities in parallel to the ongoing development work, performed mostly by the Product Owner. The Scrum Team estimates requirements whenever necessary. The sprint backlog that contains those requirements that will be tackled in a sprint is created from the Product Backlog during the Sprint Planning Meeting. Initial requirements are captured in the release planning stage, before the sprints are begun, a task similar to the *Initiate Project* activity described for the OpenUP earlier [40]. The product backlog is refined by new requirements that are created during sprints or come up during the Sprint Review. PosoMAS-Scrum does not prescribe the way requirements are captured and the example in the next section shows how goal-oriented requirements engineering can be used in this context. This is an example of process tailoring where the generic process has been adapted to suit the needs of the development effort.

PosoMAS-Scrum also encompasses activities to prepare the release of the product. For this purpose, method content from the OpenUP practice *Production Release* has been embedded at the end of the life cycle to provide guidance for the eventual rollout of the finished product. The use of this practice from a different process also illustrates the modularity of PosoMAS and OpenUP and how their elements can be combined beneficially.

**5. Sprint Example.** We present how PosoMAS-Scrum is applied in a case study that shows an excerpt of the development of a highly dynamic, self-organising material handling and order fulfilment system constituting a self-organising warehouse system inspired by the Kiva System [24]. The system has been developed in collab-



oration with students applying PosoMAS-Scrum and now serves as a proving ground for new self-optimisation and self-adaptation mechanisms. In its current form, it consists of a sophisticated simulation environment with a visualisation. It is based on the Jadex multi-agent platform [34], providing a distributed implementation of the agents and an implementation of the environment the agents interact in, including a mock enterprise resource planning system.

The case study demonstrates the strengths of PosoMAS-Scrum, illustrates the interplay of Scrum management techniques and PosoMAS technical method content, exemplifies how development progresses in PosoMAS-Scrum, and documents the use of different process activities and tasks supporting the development. While the previous description of the practices does not go down to the task level, we have included the tasks in the description to indicate which PosoMAS method content is concretely applied.

In the following, we first introduce the vision of the system to be developed before diving into the second sprint of the development process. We then discuss briefly how Posomas-Scrum has been tailored for that specific development effort before we introduce the status of the product after the first iteration. Based on this, we detail how PosoMAS-Scrum has been applied in the second sprint.

**5.1. Automated Material Handling and Order Fulfilment System.** An Automated Material Handling and Order Fulfilment System (AMHOFS) includes the “chaotic” storage of goods on shelves, the replenishment of these shelves, as well as packing parcels in “pack stations”. In the warehouse no human intervention is needed as the AMHOFS manages itself. AMHOFS are usually regarded as black boxes, i.e., the activities of the system and information such as the current place of an item or which robot does what are irrelevant to the order management system or the enterprise resource planning (ERP) system. Of course, interfaces exist so that orders generated by an ERP system are fulfilled by the AMHOFS and packed parcels are registered in the ordering system.

An AMHOFS consists of movable shelves which are transported by mobile robots to pack stations within a warehouse. Five to ten of such battery-powered robots serve one pack station to guarantee a continuous supply of shelves. At the pack station humans put goods from arriving shelves into parcels. This can be done in parallel for several parcels. The robots visit charging or repair stations from time to time. They find their path by the use of markings embedded in the ground. The control of the robots is mainly performed by a central dispatch server which registers obstacles and accordingly calculates the routes. The shelves offer a variety of rack bays, so that different product types can be placed from piece-goods to bulk-goods. They are placed in a special arrangement within the warehouse, so that shelves with highly demanded, popular goods are placed close to the relevant pack stations. The number of shelves carrying the same products, currently pending orders, and order history are included in the calculation of the arrangement. During operation the robots steadily take the appropriate shelves to the stations where goods are removed or replenished and afterwards move the shelf to a newly calculated best slot.

While the original Kiva system [24] uses a centralised dispatch system that orders the robots to fulfil certain tasks, the development effort described here implements a system in which the robots negotiate which tasks they take on and make autonomous decisions about routes and shelf placement, i.e., without control from the outside. The overall aim is to make the system more robust to failures and more scalable in the number of robots, shelves, and orders.

**5.2. Tailoring PosoMAS-Scrum for the Development Effort.** Before the start of the development effort, PosoMAS-Scrum has been tailored for the necessities expected by the Scrum Team. Since the vision of the system indicates that it is based on trustworthy individual components, the activity *Develop Trust-Based Interactions* has been excluded. Likewise, agent organisations seem to play a minor role and the associated activity is not used at this point in time. Please note that the necessities can change while the project runs and the developers can re-visit the method content at any point in time to reintroduce tasks and activities that have so far been left out.

Apart from these omissions, the Scrum Team and the Product Owner decided that they wanted to use goal-driven requirements engineering in the project. There is corresponding method content in the PosoMAS method library (cf. Sect. 3.2). Since the original method content was not written with a backlog in mind, some adaptations are necessary. The team discussed how a product and a sprint backlog can be used in conjunction with the goal models and settled on a solution in which elements from the goal model become part of the

product backlog. The transfer happens during the Sprint Planning Meetings. The Scrum Team therefore only has to deal with the backlog while the Product Owner is free to work with the goal model. During the Sprint Review, the Product Owner can check whether the goals have been fulfilled as intended and update the goal model accordingly. If the goal model has changed during the sprint, it can be synchronised with the backlog again during the Sprint Planning Meeting<sup>4</sup>.

**5.3. Status Quo after Sprint 1.** We have chosen sprint 2 as an example, because it includes several PosoMAS specific activities and tasks and is representative for a typical development sprint. Since this sprint is not the first in the development process, we briefly summarise the current status of the project.

Within sprint 1 the relevant environment of the AMHOFS system has been identified as the ERP system, that delivers the input for replenishment as well as fulfilment orders to AMHOFS (*PosoMAS-Task: Identify System Environment* from **Practice: Agent Environment Design**). The orders from the ERP—in an initial setting predefined by the developer—are processed by a dispatch server which was implemented to orchestrate the robots, shelves, pack stations, and replenishment stations. Prior to the first designs and implementations a choice has been made regarding the architecture of the agents (*PosoMAS-Task: Apply Architectural Style* from **Practice: Pattern-driven MAS Design**). The BDI architecture was chosen because of the preferences of the Scrum Team and the familiarity with the MAS framework Jadex [35]. A corresponding meta-model for this architecture is defined as a UML profile and used as the basis for the design models (*PosoMAS-Task: Apply Patterns to Agent Architecture* from **Practice: Pattern-driven MAS Design**). This flexibility is one of the advantages of PosoMAS, because the process is not restricted to any specific architecture. A first version of a general protocol for the interaction between the participants of AMHOFS has been developed. It is capable of selecting participants for several duties in the order fulfilment process (*PosoMAS-Task: Design Agent Interactions* from **Practice: Evolutionary Agent Design**). The selection is performed in a simple first come first serve manner, but the protocol has been designed to be extensible for more complex selection procedures. The output of the system is shown on a console that prints the states of all agents in the system during execution. In the current version only one instance of each agent type (robot, shelf, pack station, etc.) is used for evaluation.

**5.4. Sprint 2: Graphical Representation and Smart Shelf Placement.** Based on the current development status, the Product Owner and the Scrum Team agreed on the following two aspects for the Sprint Goal: (1) extend the representation of the system by a graphical user interface and (2) add smarter decision processes in the generic interaction protocol. The backlog has been extended appropriately (*PosoMAS-Task: Identify System Goals* and *PosoMAS-Task: Refine System Goals to Requirements* from **Practice: Goal-driven Requirements Elicitation**). The entries relevant for this sprint are shown in the goal diagram in Fig. 5.1. They are summarised by the following extensions which are also used for sprint planning:

- Graphical Interface for representation of the system (display representations of robots, shelves, and pack stations)
- Enable user input for orders (provide interface to interact with simulation)
- Tracking shelf usage for smart placement of shelves on slots (determine where to place shelves that need to be slotted, track shelf usage)
- More mobility for the robots. (move shelf to slot)
- Multiple agents per type, i.e., multiple shelves and robots in the system (no explicit goal but necessary for evaluation purposes)

The product backlog is the starting point for the Scrum Team for discussing the topics and estimating the effort of the requirements. The following shows an excerpt of the activities that have been tackled in the second sprint.

**5.4.1. Sprint Planning.** The Scrum activity “Sprint Planning” includes estimating the prioritised goals on the product backlog. Thus, the first step is the description of the highest priority backlog items by the Product Owner. If the Scrum Team has asked enough questions concerning the items to be confident to make appropriate estimations of their development effort, they start defining the goal for the sprint and estimating

<sup>4</sup>A more systematic way to connect the goal model with the various backlogs and how these artefacts are coupled is the subject of ongoing investigations.

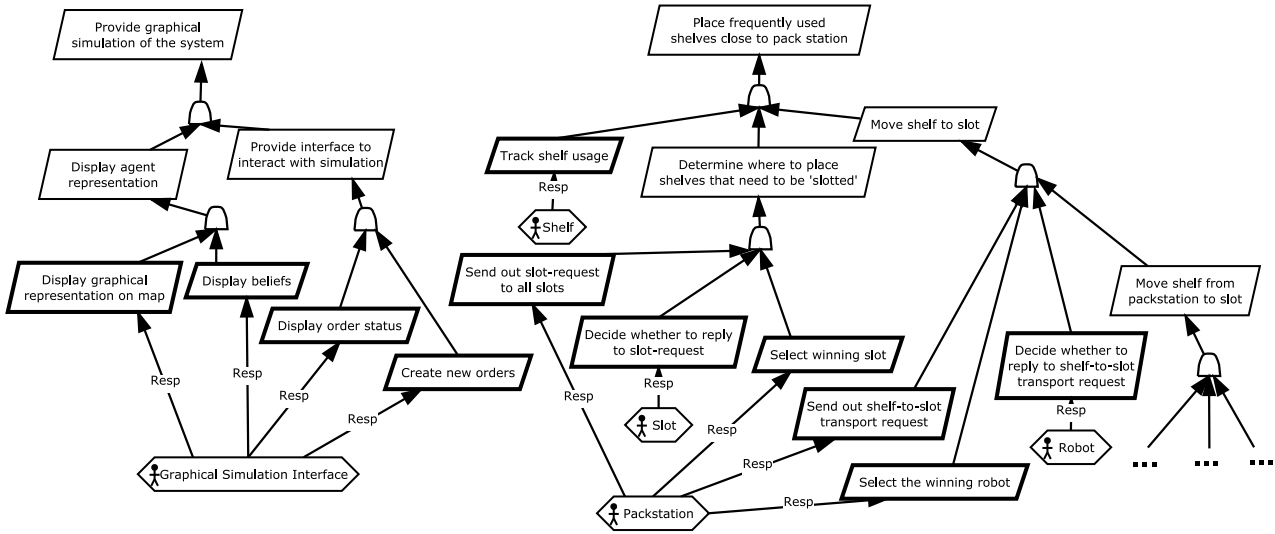

Fig. 5.1: Excerpt of the goal diagram which defines backlog items on the product backlog. After the “Task Breakdown” the goal diagram is extended by the newly defined task on the sprint backlog. Slanted rectangles are goals, slanted rectangles with a thick border are requirements. Connections between goals as well as goals and requirements indicate a refinement translation. Hexagons represent agent types and connections annotated with “Resp” indicate that the agent type is responsible for the fulfilment of the requirement.

the items subsequently. For this purpose, the Scrum Team used the planning poker technique [30] where each team member proposes an estimate at the same time using numbered cards, the estimates are discussed, and the process is iterated until a consensus is reached.

After the estimation of all product backlog entries, the requirements with the highest priority have been selected for the sprint respecting the overall velocity of the Scrum Team. The velocity of a Scrum Team is estimated by the team itself (*PosoMAS-Task* “*Estimate Velocity*”). It determines how much work the Scrum Team can take on in that iteration. Each of the requirements has been broken down into tasks according to the *PosoMAS-Task* “*Task Breakdown*”. Tasks are finer grained units of work for a requirement and are also estimated. While some tasks have been taken verbatim from the goal model (e.g., “Select winning slot”), some new tasks have been added. These are necessary to break down large requirements into manageable chunks for the sprint backlog. In AMHOFS the goal “display agent representation” has been divided into eight tasks which can not be found in the goal model but are represented on the task board. The complete sprint backlog of the current sprint is shown in Fig. 5.2.

**5.4.2. Sprint Activities.** During the sprint the Scrum Team performed several PosoMAS-Activities in order to achieve the requirements in the sprint backlog.

**Activity: Design System Dynamics** The main aim in the current sprint is to implement a graphical representation of the system and improve the movement of the robots and the shelves.

*PosoMAS-Task: Design Agent Interactions* from **Practice: Evolutionary Agent Design:** A generic protocol implementing a bidding mechanism for negotiating which agents take on which orders respectively tasks has been specified. This protocol is used for example in order to find a position for a shelf that has already been unloaded at a pack station. To place a shelf on a suitable slot, all slots receive a request from the pack station and reply whether the slot is free and suitable. The best offer of the slots is selected, i.e., based on the optimal distance to the pack station depending on the loaded goods and anticipated future orders. The robot that has to transport the shelf to the selected slot is also selected using the same generic protocol. Selection criteria for the robot include shortest distance to the shelf or battery load.

Priority	Requirement	Todo	In Progress	Done
1	40 Display agent representation	Display goods stored in shelves 5 Display road network 5 Display dispatch server 2 Display pack station 3 Display workload on agents 5 Display slots 5 Display shelves 2 Display moving robots and shelves 8		
2	13 Provide interface to interact with simulation	Display orders and their status 5 Provide GUI to add new orders from existing goods to dispatch server queue 8		
3	13 Move shelf to slot	Pickup shelf and place shelf 3 Select the winning robot 1 Decide whether to reply to a shelf-to-slot request 2 Find path to slot 5 Send out shelf-to-slot request 2 Move one step from slot neighbour slot 3		
4	5 Determine where to place shelves that need to be slotted	Send out slot-requests to all slots 1 Decide whether to reply to slot request 2 Select winning slot 2		
5	5 Track shelf usage	Remember number of visits at each pack station for each shelf 2 Save history of stored goods for each shelf 2		

Fig. 5.2: Sprint backlog/task board at the beginning of sprint 2. Requirements have been estimated using planning poker first. Then they have been broken down into tasks which have been estimated in turn. This ensures that the original estimate was sensible. Note that task estimates must not necessarily add up to the estimate of the requirement.

*PosoMAS-Task: Define Agent Capabilities and Behaviour* from **Practice: Evolutionary Agent Design:** All AMHOFS agents inherit from an abstract class called `BaseAgentBDI`. This class implements the basic functionalities for AMHOFS agents, e.g., the generic interaction protocol. Each specific agent type, e.g., the robot (responsible for transporting the shelves from point A to B), extends this base agent by specific functionality and a graphical representation. The capabilities and behaviours of the robot agent defined and implemented in the current sprint encompass the movement from a start to an end position. This movement could be carried out with or without a shelf on top. The outcome of the definition of the capabilities is shown in Fig. 5.3 as a BDI agent model for the robot. In a nutshell, a movement of a robot is triggered by some external event (change of a belief) that leads to a new goal, i.e., a `MoveGoal`. This goal in turn triggers a plan that is executed until the robot has reached the desired point. For implementing the plan the movement is fragmented into steps that in turn are realized as goals with regarding plans.

The Scrum Team made the design decision that each agent is responsible for its graphical representation and that it is always up to date. PosoMAS does not prescribe to use a specific framework to implement the application but is open for the usage of such one. In our case study we use JADEX, a MAS framework [35]. Within this framework it is easy to add a graphical representation to an agent by adding a reusable building bloc, a capability called avatar, which enables the developer to define the appearance of the agent and to update its believes in the graphical user interface. This capability is added to the generic `BaseAgentBDI` and automatically all types of agents inherit the link to their environment and only have to specify their concrete appearance properties.

**Activity: Develop Solution Increment** The aim of the activity is to build the control centre for AMHOFS, that is responsible to simulate the external ERP system and provide the necessary inputs. In

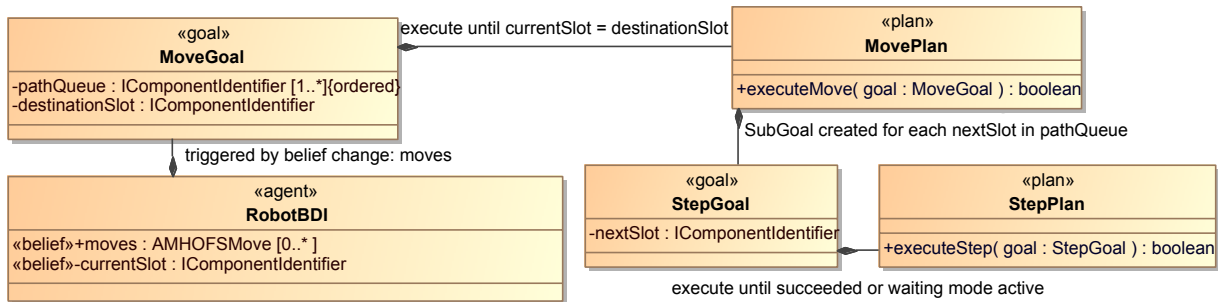

Fig. 5.3: Design of the movement capability of a robot agent as a UML diagram annotated by stereotypes. These stem from an ad-hoc BDI meta-model realised as a UML profile.

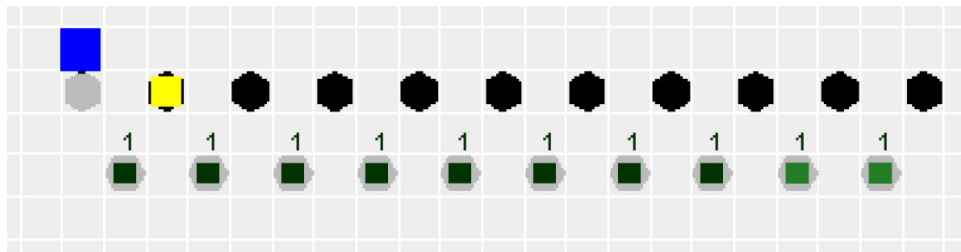

Fig. 5.4: The slots form a road network. A robot may move horizontally and vertically between the slots. The grey hexagons represent slots that are available for shelves while the black hexagons are reserved parking spaces for idle robots. Yellow squares represent robots. The shelves are shown as smaller black squares with numbers that display the number of goods placed on that particular shelf. The pack station is represented by a blue square.

addition the extensions of the generic protocol must be implemented.

*Task: Implement Solution* from the EPF base method content: To fulfil the assumption that all orders in the AMHOFS system are satisfiable the user must be prevented from creating invalid orders and assign them to the system. Therefore, a pre-defined list of available goods has been defined. The “ERP system” simulated by the user is consequently not able to demand any good that is not available. In addition, the shelves are assigned with an initial set of goods. An order is processed by the dispatch server that handles the order and distributes tasks to the shelves.

The generic interaction protocol has been adapted for the smart placement of shelves after being used at a pack station. Therefore, the decision parameters were added as defined in the *PosoMAS-Task: Design Agent Interactions*.

**5.4.3. Sprint Review.** During the review a deadlock between two moving robots has been detected that is a result of missing fallback procedures in the road network. The bug has been added to the product backlog with a rather low priority, because the overall impact of the bug is categorized as low. Furthermore, the review led to new requirements on the backlog: the graphical representation of the shelf, robot, and slot should be enriched with more details viewable in a context menu. As the outcome of sprint 2 is a shippable build of the graphical representation (see Fig. 5.4) and more flexible robots, the sprint was accepted by the Product Owner.

**5.4.4. Sprint Retrospective.** Reflecting the sprint the Scrum Team identified a major concern in the delays that were mainly caused by difficulties with the available tools and techniques for quality assurance, i.e., systematically testing and debugging the application. Especially interleaved and nested plans and goals—as necessary for the movement of the robots—are hard to debug. Furthermore, failures that occurred once are hard to reproduce, since during runtime pack stations create tasks at random and the placement of the agents

at initialisation is also randomised. As a consequence the team agreed on putting more effort in designing test scenarios for the requirements on the sprint backlog to improve the test process. Furthermore, the effort of testing has to be taken into account during the task estimation process. One of the successes of the sprint has been the use of the generic interaction protocol. The effort for designing this protocol for the agents paid off during the development of further interaction mechanisms.

**5.5. Lessons Learned.** The development of PosoMAS and PosoMAS-Scrum and the accompanying validation provided a number of lessons that have been integrated in the process and its documentation. First and foremost, the distinction of *architecture areas* is vital for the creation of a modular, flexible design. Many of the problems with the initial system design in early iterations were caused by misunderstandings about which parts of the design were on the agent level, which on the system level and in the environment, and which are part of the organisation design. Our observations with developers being rather inexperienced with agent systems and a rather coarse division of the architectural areas showed a tendency to develop a centralised system structure as in an object-oriented approach. That made it difficult to assign responsibilities to agents and to identify necessary communication flows. In contrast, an early and clear distinction, as we outlined it, helps guide the developers during the first iterations and leads to better results in forming a suitable agent-oriented system architecture. These areas have thus been discriminated more thoroughly and according tasks and guidance have been disentangled. This not only leads to a better separation of concerns in the resulting design, but in the method content as well.

Second, the concept of *scope* and thus of the system boundary has been overhauled and extended from the guidance provided by existing AOSE processes. Essentially, everything outside the scope the system has to interact with can not simply be ignored but assumptions must be captured and the environment has to be modelled accordingly. This can, at least partially, be done in the requirements engineering activities, but also impacts the design of the system. The **Practice: Agent Environment Design** has been updated in response to these necessities. Miller et al. [29] advocate—based on their own experiences—to delay the decisions of defining system boundary as long as possible and at least to wait until the stakeholders have formed a shared understanding of the problem. PosoMAS-Scrum supports delaying the decision. As long as the requirements and the necessary design documents contain the vital model elements, the point in time where the decision regarding the system boundary is made is fully up to the developers. Nevertheless, since the system boundary directly influences the project scope and thus development time and costs our experiences indicate that delaying the decision is not always beneficial.

Finally, a specialised UML profile containing stereotypes for agents, methods that are part of an agent's interface, and external components was introduced to mark specific concepts in the agent and system models, thus clarifying the semantics of the modelling elements.

Third, the combination of goal-driven requirements engineering and Scrum warrants a more detailed discussion. While the approach described here worked well enough in the context it was used, there are a number of challenges that were discovered. One aspect is that coming to an initial version of the goal model that can be used as the source for the first product backlog is challenging. The life cycle we chose allows for an initialisation phase that can contain a longer initial requirements engineering effort. How long this takes in practice was, however, underestimated. Furthermore, when elements from the goal model are transferred to the Sprint Backlog, they should be locked in the goal model. If not, the Product Owner might change the goals that the team is currently working on and this change can go undetected until the next Sprint Planning session when the artefacts are synchronised. As mentioned before, this area is subject of future work.

**6. Related Work and Comparison.** This section introduces the most relevant existing AOSE methodologies and then compares a selection of these to PosoMAS-Scrum. A more in-depth comparison and additional information about these other processes can be found at <http://posomas.isse.de>.

**6.1. Characteristics of Existing AOSE Methodologies.** There are a number of AOSE methodologies and this section aims at pointing out their unique characteristics. Apart from the original papers on the methodologies, we also use content provided by attempts to compare methodologies. Such comparative studies (e.g., [45]) are, however, to be taken with a grain of salt, since the set of evaluation criteria used are not necessarily agreed-upon standards. Since such standards are missing, however, these studies currently provide the only

reference point for comparing AOSE methodologies. The processes selected below have been mainly chosen due to the currentness of the published method content. A recent overview of agent-oriented design processes is presented in [12] where a number of processes are cast in the IEEE FIPA Process Documentation Template but the book offers no significant *new* method content or a qualitative comparison of the methodologies.

In the following, we refer to the requirements defined in Sect. 2. As discussed there, these requirements make sense for many circumstances but we make no claim for their generality for specific development efforts. They aim at providing flexible method content and support for the system class we are concerned with. If these requirements are relevant for a specific development effort must be checked before a decision for a process is made.

The **Prometheus** methodology [32] combines specification, design, and implementation in a detailed process and is commonly accepted as one of the most mature AOSE approaches (cf. [44, 2, 13]). Prometheus uses a bottom-up approach for the development of multi-agent systems with BDI agents. While the focus on BDI is often lauded [2, 13], some authors criticise that this constitutes a restriction of application domains [44]. According to [32], however, only a subset of Prometheus is specific to BDI. Still, *independence* is thus limited. The process has no notion of agent organisation and focuses solely on *interactions* between the agents. This also limits the *separation of architecture domains*. A main feature are detailed guidelines that support the development steps, as well as support for validation, code generation, consistency checks, testing and debugging. These guidelines promote *extensibility* but it is unclear how the process can be adapted to different process lifecycles.

**ADELFE** has been specifically developed for the design of adaptive multi-agent systems (AMAS) with emergent functionality [7]. The methodology follows the Rational Unified Process (RUP) closely and uses UML and AUML, an extension of the UML meta-model with agent-specific concepts [4]. The method content for ADELFE is provided in SPEM format, making it *extensible* and reusable. It follows principles from the AMAS theory as well as classical object-oriented approaches. Adherence to the AMAS theory is also the main criteria when assessing the applicability of ADELFE for a specific system: it should have a certain complexity and should be open. Additionally, the development of algorithmic solutions to the core problems is an integral part of the process and therefore, the approach is mainly suitable when the algorithms are not known yet. This severely limits the methodology's *independence*. If an agent reaches a certain complexity in ADELFE, it is treated as a separate AMAS, thus providing a focus on *interaction* between agents and agent organisations. This also provides some separation of *architecture domains*, but the process does not provide guidelines on the separate, principled modelling of these domains.

**ASPECS** focuses on complex systems with an emphasis on holonic organisations [10] based on the PASSI methodology. A holon is here defined as “[...] self-similar structure composed of holons as sub-structures”. The organisation into holons is captured in a meta-model that is used for the definition of the system structure. An important principle leveraged in ASPECS is the possibility of stepwise refinement of the holons. Like ADELFE, the methodology therefore has drawbacks w.r.t. *independence* and, in addition, relies on a specific meta-model. It is, however, extensible since the method content is available online. Both *separation of architecture domains* and a focus on *interactions* are ensured.

The *Multiagent Systems Engineering* methodology **MaSE** includes a development life cycle starting from the initial system specification and including implementation and deployment [15, 2, 13]. It has been applied in several research projects and has been lauded for its comprehensibility [44]. MaSE is *independent* of a specific agent architecture and can therefore be applied to heterogeneous systems [2]. A strength of the methodology is the way agent interactions and protocols are defined. Drawbacks are the complex description of concurrent tasks, the absence of models for the environment and agent behaviour, and missing specification tools for agent adaptivity [1, 13]. In addition, the methodology was difficult to customise and organisational factors were not considered [14]. Based on this criticism, **O-MaSE** and “agentTool”<sup>5</sup> have been developed [14]. They provide a method engineering framework with which method fragments specified as SPEM<sup>1</sup> activities can be composed. The method content is based on a common meta-model and focuses mainly on analysis, design, and implementation. Organisations and the environment are now explicitly considered. *Extensibility* and *independence* are limited due to the specialised tool required and due to the meta-model. O-MaSE provides no

<sup>5</sup><http://agenttool.cis.ksu.edu/>

overall system design activities, thus reducing the *separation of architecture domains*.

**INGENIAS** [33] aims at the development of organisational multi-agent systems and is the descendant of MESSAGE [8]. It uses meta-models to describe the relevant concepts in different aspects or “viewpoints” of a MAS, including organisation, agent, goals/tasks, interactions, and environment [33]. Relationships between the concepts for the different viewpoints are exploited to ensure consistency of the modelling. Meta-models are described in a specialised modelling language. The agents are based on BDI. INGENIAS is supported by specialised tools for modelling and process customisation. While this limits the *extensibility* and *independence* of the methodology, it offers full support for *separation of architecture domains* and for *interactions* between agents and agent organisations. The methodology is supported by specialised tools, the “INGENIAS Development Kit (IDK)” and the “INGENIAS Editor”<sup>6</sup>. INGENIAS originally uses the life cycle of the Unified Process, allowing an iterative and incremental development, but a version using Scrum as a framework has been suggested [19]. Similar to PosoMAS-Scrum, the method content is embedded in the iterative-incremental lifecycle and supplemented by typical Scrum activities.

From the remarks above, it becomes clear that all AOSE methodologies support a different set of requirements and apply to different types of systems. A more detailed comparison between PosoMAS-Scrum, Prometheus, ADELFE, and INGENIAS-Scrum is shown below. However, it must be noted that not all requirements apply to all development situations. For some teams, it might be helpful to have a meta-model available or support by a dedicated tool. Others do not require support for agent organisations since the scale of the system under development is low or more complex organisational structures are not needed. In such situations, PosoMAS may not be an ideal candidate and one of the other methodologies may be better suited. It is thus important to consider the actual requirements of the development effort before choosing a process [21].

**6.2. Comparison between AOSE Processes.** The validation of a software engineering process is difficult from a methodical point of view. Ideally, the process is tested in a productive environment for the creation of a software product with an experienced team of software engineers and developers who can compare the effort to previous experiences with other methodologies. Such an approach, however, is not feasible in the scope in which AOSE methodologies are created at the moment. Instead, we rely on qualitative evaluation and validation criteria. Tran et al. [45, 44] have introduced a catalogue of criteria that are used in Table 6.1 to show the characteristics of PosoMAS and to compare it to other approaches. These criteria are related to the support the methodologies give in different areas. To ensure that all relevant aspects of the development process are covered, Tran et al. identified 19 commonly used development steps that were confirmed to be necessary by a survey conducted among experts. The set of criteria can therefore be considered quite exhaustive.

It should be noted that such a comparison is not suitable to make a statement about which methodology is “better” in general, but rather serves as an aid in deciding which of the methodologies is suitable in a specific development project. If such a project, e.g., requires explicit support for proactivity, Prometheus, ASPECS, or INGENIAS-Scrum might be more suitable than PosoMAS-Scrum. On the other hand, if the focus is on the development of an open system, PosoMAS-Scrum has advantages. Likewise, while Table 6.1 might give the impression that ASPECS covers more criteria and is therefore suitable in all situations in which PosoMAS-Scrum can be applied, this is not actually true since ASPECS prescribes the use of holons and a specific meta-model that is not suitable to all projects. Ideally, a situational method engineering approach (cf. Sect. 3.1) would identify method content from different methodologies that fits the project and combine it. Unfortunately, this is difficult since most processes lack a readily available machine-readable standardised process description.

Table 6.1 only captures if a process has explicit supporting content for a certain criterion. It is, e.g., possible to build proactive systems with PosoMAS even though the process does not include specific support for them. The process website contains a detailed description of the criteria and comparisons under different aspects and for additional methodologies.

The basis for the evaluation of PosoMAS-Scrum is the development effort described in Sect. 5. The OpenUP-based version of PosoMAS has been evaluated with two simulated case studies, one of which — a power management example — is available online along with a detailed description and a selection of artefacts. Information about the other processes has been extracted from the relevant literature. We present the characteristics of

<sup>6</sup><http://ingenias.sourceforge.net/>



Table 6.1: Characteristics of PosoMAS-Scrum, Prometheus, ASPECS, and INGENIAS-Scrum based on [45, 44, 32, 10, 19, 18, 12]. More details on criteria and values on <http://posomas.isse.de>.

Criteria	PosoMAS-Scrum	Prometheus	ASPECS	INGENIAS-Scrum
Process-Related Criteria				
Development lifecycle	Iterative-incremental life cycle	Iterative across all phases	Iterative-incremental life cycle	Iterative-incremental life cycle
Coverage of the lifecycle	Requirements, Analysis, Design, Management	Analysis, Design	Analysis, Design, Test, Deployment	Analysis, Design, Implementation, Deployment, Management
Development perspectives	Hybrid	Bottom-Up	Top-Down	Top-Down
Application Domain	Any	Any	Any	Any
Size of MAS	Not Specified	Not Specified	Not Specified	Not Specified
Agent paradigm	Heterogeneous	BDI	Holonic	BDI
Model Validation	Yes	Consistency and completeness	No	Yes
Refinability	Yes	Yes	Yes	Yes
Approach towards MAS development	Object-Oriented, Non-Role-Based	Object-Oriented, Non-Role-Based	Role-Based, Knowledge Engineering	Goal-Oriented, Role-Based
Meta-model based	No	No	Yes	Yes
Model-Related Criteria				
Syntax and Semantics	Medium	High	High	High
Model transformations	Yes	Yes	Yes	Yes
Consistency	Yes	Yes	Yes	Yes
Modularity	Yes	Yes	Yes	Yes
Abstraction	Yes	Yes	Yes	Yes
Autonomy	Yes	Yes	Yes	Yes
Adaptability	No	No	Yes	Yes
Cooperation	Yes	Yes	Yes	Yes
Inferential capability	No	Yes	No	No
Communication	Yes	Yes	Yes	Yes
Reactivity	Yes	Yes	Yes	Yes
Proactivity	No	Yes	Yes	Yes
Concurrency	No	No	No	No
Model Reuse	Yes	Yes	Yes	Yes
Supportive Feature Criteria				
Software and methodological support	Yes	Yes	Yes	Yes
Open systems and scalability	Yes	No	Yes	No
Dynamic structure	Yes	No	Yes	No
Performance and robustness	Yes	Yes	Yes	No
Support for conventional objects	Yes	Yes	Yes	Yes
Support for self-interested agents	Yes	No	Yes	No
Support for ontologies	No	No	Yes	No

PosoMAS-Scrum, Prometheus, ASPECS, and INGENIAS-Scrum in Table 6.1. These processes have been chosen due to their pervasiveness (Prometheus), their currentness (ASPECS), and their use of the same development framework (INGENIAS-Scrum). Comparisons with other processes, including O-MaSE, Gaia, and Tropos can be found at <http://posomas.isse.de>.

**7. Discussion and Future Work.** This paper introduced PosoMAS-Scrum, an agile agent-oriented software engineering process for the class of large-scale open self-organising systems. We demonstrate how it can be applied in a development effort and show how it compares with existing approaches. We also demonstrate how easy it is to combine it with method content from other processes and to tailor it to the specific needs of a development effort or the predilections of the developers.

We are not claiming that PosoMAS-Scrum or its OpenUP-based cousin PosoMAS will be suitable in all circumstances or are in general “better” than existing AOSE approaches. Most of these methodologies are very

concrete and prescribe solution approaches, techniques, and models in great detail. Such an approach excels when a system fits the assumptions made by giving much more hands-on support. However, it is rare that a product fits the assumptions perfectly. PosoMAS and PosoMAS-Scrum try to find a middle ground between these extremes by providing guidance without forcing adherence to a special paradigm and by formulating method content in a way that lends itself to process customisation and tailoring. The comparisons in Table 6.1 can provide indications of the strength and weaknesses of the different processes and a starting point for selecting a suitable process for a given project.

Most processes impose a certain way of thinking about the system under construction. Prometheus enforces the use of BDI-agents, O-MaSE puts the focus on organisations, and ASPECS forces developers to think in terms of ontologies and holarchies. PosoMAS has been designed to be independent of most of these factors but still contains elements that favour certain solutions, e.g., using the Observer/Controller architectural pattern as the basis for adaptation. When choosing a process, the development team has to make sure that the perspective taken by the process is compatible with the product.

Our main initiative for future work is to apply PosoMAS-Scrum in an industrial project to validate and refine it according to the needs of an industrial partner. Additional future work includes the creation and integration of additional method content, especially w.r.t. testing of self-organising systems. A more in-depth comparison of agent-oriented software engineering approaches is also under development. In addition, a stronger and more principled combination of goal-driven requirements engineering with the different backlogs used in Scrum will be developed. Our hope, however, is that by making PosoMAS and all method content available as a repository at <http://posomas.isse.de> both in browsable form and as EPF source code, other researchers and practitioners will start using the practices and the framework they provide to adapt the process, create new methodologies, and enrich the content with their own ideas and concepts<sup>7</sup>.

#### REFERENCES

- [1] T. ABDELAZIZ, M. ELAMMARI, AND R. UNLAND, *A Framework for the Evaluation of Agent-Oriented Methodologies*, in 4th Int. Conf. on Innovations in Information Technology. IIT '07., November 2007, pp. 491–495.
- [2] EBRAHIM AL-HASHEL, BALA BALACHANDRAN, AND DHARMENDRA SHARMA, *A Comparison of Three Agent-Oriented Software Development Methodologies: ROADMAP, Prometheus, and MaSE*, in Knowledge-Based Intelligent Information and Engineering Systems, Bruno Apolloni, Robert Howlett, and Lakshmi Jain, eds., vol. 4694 of LNCS, Springer, Berlin, Heidelberg, 2007, pp. 909–916.
- [3] SCOTT W. AMBLER, *The agile system development life cycle (sdic)*. Ambyssoft Inc. Website, 2012.
- [4] BERNHARD BAUER, JÖRG P. MÜLLER, AND JAMES ODELL, *Agent UML: a formalism for specifying multiagent software systems*, in AOSE 2000, Secaucus, NJ, USA, 2001, Springer, pp. 91–103.
- [5] KENT BECK, MIKE BEEDLE, ARIE VAN BENNEKUM, ALISTAIR COCKBURN, WARD CUNNINGHAM, MARTIN FOWLER, JAMES GRENNING, JIM HIGHSMITH, ANDREW HUNT, RON JEFFRIES, ET AL., *The agile manifesto*, 2001.
- [6] YVONNE BERNARD, LUKAS KLEJNOWSKI, CHRISTIAN MÜLLER-SCHLOER, JEREMY PITT, AND JULIA SCHAUMEIER, *Enduring institutions and self-organising trust-adaptive systems for an open grid computing infrastructure*, in Proc. of the 2012 Sixth IEEE Int. Conf. on Self-Adaptive and Self-Organizing Systems Workshop (SASOW), IEEE, 2012, pp. 47–52.
- [7] CAROLE BERNON, MARIE-PIERRE GLEIZES, SYLVAIN PEYRUQUEOU, AND GAUTHIER PICARD, *ADELFE: a methodology for adaptive multi-agent systems engineering*, in Proc. of the 3rd Int. Conf. on Engineering Societies in the Agents World III, ESAW'02, Berlin, Heidelberg, 2003, Springer, pp. 156–169.
- [8] GIOVANNI CAIRE, WIM COULIER, FRANCISCO GARIJO, JORGE GOMEZ, JUAN PAVON, FRANCISCO LEAL, PAULO CHAINHO, PAUL KEARNEY, JAMIE STARK, RICHARD EVANS, AND PHILIPPE MASSONET, *Agent oriented analysis using message/uml*, in Agent-Oriented Software Engineering II, Michael J. Wooldridge, Gerhard Weiß, and Paolo Ciancarini, eds., vol. 2222 of LNCS, Springer, Berlin, Heidelberg, 2002, pp. 119–135.
- [9] BETTY CHENG, PETE SAWYER, NELLY BENCOMO, AND JON WHITTLE, *A goal-based modeling approach to develop requirements of an adaptive system with environmental uncertainty*, in Model Driven Engineering Languages and Systems, vol. 5795 of LNCS, Springer, Berlin, Heidelberg, 2009, pp. 468–483.
- [10] MASSIMO COSSENTINO, NICOLAS GAUD, VINCENT HILAIRE, STÉPHANE GALLAND, AND ABDERRAFIÂA KOUKAM, *ASPECS: an agent-oriented software process for engineering complex systems*, Autonomous Agents and Multi-Agent Systems, 20 (2010), pp. 260–304.
- [11] MASSIMO COSSENTINO, MARIE-PIERRE GLEIZES, AMBRA MOLESINI, AND ANDREA OMICINI, *Processes engineering and AOSE*, in Proc. of the 10th Int. Conf. on Agent-oriented Software Engineering (AOSE'09), vol. 6038 of LNCS, Berlin, Heidelberg, 2011, Springer, pp. 191–212.

<sup>7</sup>All content is made available under the Creative Commons–Attribution-ShareAlike License v3.0 (<http://creativecommons.org/licenses/by-sa/3.0/>).

- [12] MASSIMO COSENTINO, VINCENT HILAIRE, AMBRA MOLESINI, AND VALERIA SEIDITA, eds., *Handbook on Agent-Oriented Design Processes*, Springer Berlin Heidelberg, 2014.
- [13] KHANH HOA DAM AND MICHAEL WINIKOFF, *Comparing Agent-Oriented Methodologies*, in Proc. of the 5th Int. Bi-Conf. Workshop on Agent-Oriented Information Systems, Paolo Giorgini and Michael Winikoff, eds., Melbourne, Australia, 2003, pp. 52–59.
- [14] SCOTT A. DELOACH AND JUAN CARLOS GARCIA-OJEDA, *O-MaSE – a customisable approach to designing and building complex, adaptive multi-agent systems*, IJAOSE, 4 (2010), pp. 244–280.
- [15] SCOTT A. DELOACH, MARK F. WOOD, AND CLINT H. SPARKMAN, *Multiagent Systems Engineering*, IJSEKE, 11 (2001), pp. 231–258.
- [16] BENEDIKT EBERHARDINGER, HELLA SEEBACH, ALEXANDER KNAPP, AND WOLFGANG REIF, *Towards testing self-organizing, adaptive systems*, in ICTSS 2014, Mercedes G. Merayo and Edgardo Montes de Oca, eds., vol. 8763 of LNCS, Springer, Berlin, Heidelberg, 2014, pp. 180–185.
- [17] BENEDIKT EBERHARDINGER, JAN-PHILIPP STEGHÖFER, FLORIAN NAFZ, AND WOLFGANG REIF, *Model-driven Synthesis of Monitoring Infrastructure for Reliable Adaptive Multi-Agent Systems*, in Proc. of the 24th IEEE Int. Symposium on Software Reliability Engineering (ISSRE 2013), Washington, D.C., November 2013, IEEE Computer Society.
- [18] ALMA GÓMEZ-RODRÍGUEZ, RUBÉN FUENTES-FERNÁNDEZ, JUAN C. GONZÁLEZ-MORENO, AND FRANCISCO J. RODRÍGUEZ-MARTÍNEZ, *Ingenias with the unified development process*, in Handbook on Agent-Oriented Design Processes, Massimo Cossentino, Vincent Hilaire, Ambra Molesini, and Valeria Seidita, eds., Springer Berlin Heidelberg, 2014, pp. 371–405.
- [19] JUAN C. GONZÁLEZ-MORENO, ALMA GÓMEZ-RODRÍGUEZ, RUBÉN FUENTES-FERNÁNDEZ, AND DAVID RAMOS-VALCÁRCCEL, *Ingenias-scrum*, in Handbook on Agent-Oriented Design Processes, Massimo Cossentino, Vincent Hilaire, Ambra Molesini, and Valeria Seidita, eds., Springer Berlin Heidelberg, 2014, pp. 219–251.
- [20] BJORN GUSTAFSSON, *OpenUP – The Best of Two Worlds, Methods & Tools*, (2008).
- [21] BRIAN HENDERSON-SELLERS AND JOLITA RALYTÉ, *Situational method engineering: State-of-the-art review*, Journal of Universal Computer Science, 16 (2010), pp. 424–478.
- [22] JON HIMOFF, PETR SKOBELEV, AND MICHAEL WOOLDRIDGE, *Magenta technology: Multi-agent systems for industrial logistics*, in Proc. of the Fourth Int. Joint Conf. on Autonomous Agents and Multiagent Systems, AAMAS '05, ACM, 2005, pp. 60–66.
- [23] BRYAN HORLING AND VICTOR LESSER, *A survey of multi-agent organizational paradigms*, The Knowledge Engineering Review, 19 (2004), pp. 281–316.
- [24] KIVA SYSTEMS, *Defying the Laws of Fulfillment – The Kiva Mobile Fulfillment System*. <http://www.kivasystems.com/media/45933/kiva%20systems%20brochure%20-%20defying%20the%20laws%20of%20fulfillment.pdf>, accessed March 24th, 2015.
- [25] PER KROLL AND PHILIPPE KRUCHTEN, *The Rational Unified Process Made Easy—A Practitioner’s Guide to the RUP*, Addison-Wesley Professional, 2003.
- [26] AXEL LAMSWEERDE AND EMMANUEL LETIER, *From object orientation to goal orientation: A paradigm shift for requirements engineering*, in Radical Innovations of Software and Systems Engineering in the Future, vol. 2941 of LNCS, Springer, Berlin, Heidelberg, 2004, pp. 325–340.
- [27] P. LEITAO, V. MARIK, AND P. VRBA, *Past, present, and future of industrial agent applications*, Industrial Informatics, IEEE Transactions on, 9 (2013), pp. 2360–2372.
- [28] V. MARIK AND D. MCFARLANE, *Industrial adoption of agent-based technologies*, Intelligent Systems, IEEE, 20 (2005), pp. 27–35.
- [29] T. MILLER, BIN LU, L. STERLING, G. BEYDOUN, AND K. TAVETER, *Requirements elicitation and specification using the agent paradigm: The case study of an aircraft turnaround simulator*, Software Engineering, IEEE Transactions on, 40 (2014), pp. 1007–1024.
- [30] KJETIL MOLOKKEN-ØSTVOLD, NILS CHRISTIAN HAUGEN, AND HANS CHRISTIAN BENESTAD, *Using planning poker for combining expert estimates in software projects*, Journal of Systems and Software, 81 (2008), pp. 2106–2117.
- [31] RICHARD MOORE, KELLY REFF, JAMES GRAHAM, AND BRIAN HACKERSON, *Scrum at a fortune 500 manufacturing company*, in Agile Conf. (AGILE), 2007, IEEE, 2007, pp. 175–180.
- [32] LIN PADGHAM AND MICHAEL WINIKOFF, *Developing Intelligent Agent Systems*, John Wiley & Sons, Ltd, 2005.
- [33] JUAN PAVÓN AND JORGE GÓMEZ-SANZ, *Agent oriented software engineering with INGENIAS*, in CEEMAS'03, LNCS, Berlin, Heidelberg, 2003, Springer, pp. 394–403.
- [34] ALEXANDER POKAHR AND LARS BRAUBACH, *From a research to an industrial-strength agent platform: Jaded v2*, in Business Services: Konzepte, Technologien, Anwendungen – 9. Internationale Tagung Wirtschaftsinformatik (WI 2009), Hans-Georg Fill Hans Robert Hansen, Dimitris Karagiannis, ed., Österreichische Computer Gesellschaft, 2 2009, pp. 769–778.
- [35] ALEXANDER POKAHR, LARS BRAUBACH, CHRISTOPHER HAUBECK, AND JAN LADIGES, *Programming BDI agents with pure java*, in Multiagent System Technologies - 12th German Conference, MATES 2014, Stuttgart, Germany, September 23-25, 2014. Proceedings, 2014, pp. 216–233.
- [36] URBAN RICHTER, MOEZ MNIF, JÜRGEN BRANKE, CHRISTIAN MÜLLER-SCHLOER, AND HARTMUT SCHMECK, *Towards a generic observer/controller architecture for Organic Computing*, in 36. Jahrestagung der GI, vol. 93 of LNI, GI, 2006, pp. 112–119.
- [37] KEN SCHWABER AND JEFF SUTHERLAND, *The scrum guide—the definitive guide to scrum: The rules of the game*, Scrum.org, (2011).
- [38] HELLA SEEBACH, FLORIAN NAFZ, JAN-PHILIPP STEGHÖFER, AND WOLFGANG REIF, *A software engineering guideline for self-organizing resource-flow systems*, in IEEE International Conference on Self-Adaptive and Self-Organizing System (SASO), Budapest, Hungary, 2010, IEEE Computer Society, Washington, D.C., pp. 194–203.
- [39] VALERIA SEIDITA, MASSIMO COSENTINO, AND SALVATORE GAGLIO, *A repository of fragments for agent systems design*, in Proc. Of the Workshop on Objects and Agents (WOA06), Catania, Italy, September 2006, pp. 130–137.

- [40] JAN-PHILIPP STEGHÖFER, HELLA SEEBACH, BENEDIKT EBERHARDINGER, AND WOLFGANG REIF, *Posomas: An extensible, modular se process for open self-organising systems*, in PRIMA 2014: Principles and Practice of Multi-Agent Systems, HoaKhanh Dam, Jeremy Pitt, Yang Xu, Guido Governatori, and Takayuki Ito, eds., vol. 8861 of Lecture Notes in Computer Science, Springer International Publishing, 2014, pp. 1–17.
- [41] JAN-PHILIPP STEGHÖFER, GERRIT ANDERS, FLORIAN SIEFERT, AND WOLFGANG REIF, *A system of systems approach to the evolutionary transformation of power management systems*, in Proc. of INFORMATIK 2013 – Workshop on “Smart Grids”, vol. P-220 of LNI, Bonner Köllen Verlag, 2013.
- [42] JAN-PHILIPP STEGHÖFER, PASCAL BEHRMANN, GERRIT ANDERS, FLORIAN SIEFERT, AND WOLFGANG REIF, *HiSPADA: Self-Organising Hierarchies for Large-Scale Multi-Agent Systems*, in ICAS 2013, 9th Int. Conf. on Autonomic and Autonomous Systems, Lisbon, Portugal, March 2013, IARIA, pp. 71–76.
- [43] JAN SUDEIKAT, JAN-PHILIPP STEGHÖFER, HELLA SEEBACH, WOLFGANG REIF, WOLFGANG RENZ, THOMAS PREISLER, AND PETER SALCHOW, *On the combination of top-down and bottom-up methodologies for the design of coordination mechanisms in self-organising systems*, Information and Software Technology, 54 (2012), pp. 593–607.
- [44] QUYNH-NHU NUMI TRAN, GRAHAM LOW, AND MARY-ANNE WILLIAMS, *A preliminary comparative feature analysis of multi-agent systems development methodologies*, in Proc. of the 6th Int. Conf. on Agent-Oriented Information Systems II, AOIS’04, Berlin, Heidelberg, 2005, Springer, pp. 157–168.
- [45] QUYNH-NHU NUMI TRAN AND GRAHAM C LOW, *Agent-oriented methodologies*, Idea Group, Hershey, PA, 2005, ch. Comparison of ten agent-oriented methodologies, pp. 341–367.

*Edited by:* Hoa Dam

*Received:* April 15, 2015

*Accepted:* January 13, 2016



## MODELLING DYNAMIC NORMATIVE UNDERSTANDING IN AGENT SOCIETIES

CHRISTOPHER K. FRANTZ\*, MARTIN K. PURVIS, BASTIN TONY ROY SAVARIMUTHU† and MARIUSZ NOWOSTAWSKI‡

**Abstract.** Agent-based Modelling appears as a promising analytical tool when it comes to a lasting question: in how far did different institutions affect the social and economic outcomes of societies? Taking an incremental step to address this question, we present a refined approach that combines existing institution representations (the *structure*) with a norm identification *process* to systematically ‘grow’ normative understanding from the bottom up without relying on any prior knowledge. The proposed mechanism provides agents with the ability a) to detect complex normative behaviour by developing and differentiating stereotypes of social actors, and b) to generalise behaviour beyond observed social entities, giving agents the ability to develop normative understanding as a potential precursor for predicting newcomers’ behaviours. We exemplify this approach using a simulated prototypical trader scenario that is evaluated with respect to behavioural diversity (different compositions of non-/cooperative agents) as well as structural diversity (different types of agents). Using the simulation results, we showcase the explanatory power of the derived normative understanding beyond the interpretation of quantitative results, and finally discuss the generalisability of the proposed approach.

**Key words:** Norms, Institutions, Institutional Grammar, Norm Generalisation, Norm Synthesis, Nested ADICO, nADICO, Dynamic Deontics, Normative Understanding, Maghribi Traders Coalition, Social Simulation, Agent-Based Modelling, Agent-Based Institutional Modelling

**AMS subject classifications.** 68T42, 68U20

**1. Introduction.** Institutional modelling has received increasing attention in the area of multi-agent systems, and multi-agent-based simulation, such as in [17, 2, 45]. One central driver is the continued interest in explaining socio-economic development based on the institutional environment that either fostered or restrained economic development, which is a key theme of the area of New Institutional Economics [48]. Agent-based modelling is particularly useful in this context, since it can model human interaction on multiple levels of social organisation (micro, meso, macro) and provide insight into the emergence of behavioural regularities.

This work contributes to this discussion by proposing mechanisms that allow us to ‘grow’ institutional understanding using the very individuals that are subject to the established institutions. In this context, we interpret institutions from a behavioural perspective as *manifestations of social behaviour* that transcend the individuals that constitute them and exist in the form of conventions (e.g. use of left or right road side), social norms (e.g. littering in the park), or formal laws and rules (e.g. contracts, traffic rules). The proposed mechanism is an extension of the approach previously introduced in [15] and attempts to make bottom-up emergence processes accessible using a human-readable structural representation (introduced in previous work [13, 14]) that captures the institutional spectrum. The concrete contribution includes a systematic formalisation of the individual norm generalisation steps, along with proposing a novel approach to multi-level norm generalisation based on social structures.

Doing so, this work attempts to integrate ‘structure’ and ‘process’ to provide a generalisable framework that allows for an accessible representation of institutional emergence, with particular focus on social norms. In the area of normative modelling, this work bears relationships to two research areas, namely institution representations as well as norm synthesis.

In the following Section 2 we lay out the motivation in more detail in the light of existing work from the area of normative modelling. In Section 3 we introduce the utilised structural and conceptual representations, before moving towards the description of the proposed norm generalisation process in Section 4. In Sections 5 and 6 we apply this mechanism to a prototypical scenario that models economic cooperation based on informal institutions to show the process’ inner workings as well as its explanatory value. We conclude our work with a discussion of the contribution and its potential applications in Section 7.

\*College of Enterprise and Development, Otago Polytechnic, New Zealand ([christopher.frantz@op.ac.nz](mailto:christopher.frantz@op.ac.nz))

†Department of Information Science, University of Otago, New Zealand ([martin.purvis, tony.savarimuthu}@otago.ac.nz](mailto:{martin.purvis, tony.savarimuthu}@otago.ac.nz))

‡Faculty of Computer Science and Media Technology, Gjøvik University College, Norway ([mariusz.nowostawski@hig.no](mailto:mariusz.nowostawski@hig.no))

**2. Background, Related Work & Motivation.** Coordination in human societies is increasingly recognised as important, if not decisive, to set societies on a path towards prosperity [19, 1]. Realistic artificial models of human societies thus afford mechanisms that are able to replicate behaviour leading to the emergence of different forms of stabilising behavioural manifestations, or institutions. Even though this challenge is not novel in the context of computational modelling but goes back to the pioneering works on norm synthesis by Shoham and Tennenholtz [38, 40], recent works have made promising advances in the context of online norm synthesis, thus inferring normative behaviour at runtime, as opposed to identifying norms *ex post* (offline detection). Recent works in this area specifically include Morales et al. [28, 29, 27] and Riveret et al. [37] that put emphasis on learning-centred bottom-up inference of norms.

Morales et al. [27] propose a framework that identifies and selects norms based on their effectiveness and efficiency. It does so using a central monitor that observes behaviours and performs the balancing act of proposing the greatest possible generalisation while avoiding overregulation. Their model applies case-based reasoning to inform future action choices and uses the concept of a *Normative Network* to represent the interrelationships between systems of norms and to resolve norm conflicts. The efficiency of their system is described in the context of traffic scenario inspired by Shoham and Tennenholtz [39].

Riveret et al. [37] propose a transfiguration mechanism in which agents learn norms from the bottom up and use collective action to arrive at a consensus about the normative content, before enforcing this agreed-upon prescription collectively. The authors' intent is to retrace the establishment of self-governing systems by marrying bottom-up and top-down perspective on institutions, which they operationalise using stochastic games.

In contrast to the previous works the approach proposed in this work is not primarily informed from a technological perspective that yields towards the engineering of efficient normative outcomes. Instead of controlling norm emergence with top-down processes, we emphasise the sociological perspective, with the intent to remodel characteristics typical for actual human societies, including complex behaviour that produces undesirable or even seemingly inconsistent results. We further tolerate the establishment of inefficient norms (see e.g. [6]) that the regulatory artefacts of the mentioned works prevent by design.

We entertain a comparatively broad understanding of institutions [31, 19], interpreting institutions as 'manifestations of social behaviour'. Though being concise, this understanding captures the essence of institutions, which includes a) their grounding in interaction among individuals and/or groups, and b) their stability characteristics that allows institutions to potentially survive the circumstances (and thus purpose) that brought them about (see e.g. [35]). This understanding captures a broad range of institution types that reach from self-enforcing conventions, via decentrally enforced (informal) social norms, to centrally enforced (formal) rules. For this reason in this work we seek to operationalise a general representation for institutions, such as that found in Crawford and Ostrom's Grammar of Institutions [11], whose specification has previously been refined in [13]. For our purposes the effectiveness of the 'grammar' lies in its accessible human-readable interpretation, consideration of social structures (e.g. actors) as well as actions, along with its cross-disciplinary applicability (see e.g. [42, 41, 17]). In the context of social simulation, we can thus use it as an expressive interface between the experimenter and the observed artificial society.

The present work continues the refinement of this structural representation (building on [13] and [14]) and the associated systematic process (initially introduced in [15]) that describes how individuals can develop normative understanding based on generalised experience and observations.

The essential contribution of this work is firstly to provide a systematic formalisation of the individual norm generalisation steps, and secondly, to introduce a notion of multi-level generalisation of social structures, the latter of which provides the foundation to generalise behaviour beyond the observed social entities and potentially enabling the prediction of newcomers' behaviours. The introduced example further showcases how this generated normative understanding can support the interpretation of emerging behaviour, a challenge that is particularly prevalent in complex social scenarios.

This process is driven by three key themes, that is a) the inherent decentralised nature without central coordinating entity, b) the strong generalisability by making minimal assumptions about cognitive capabilities of agents as well as absence of a priori knowledge about actions or social structures, and c) the accessibility to the human experimenter.

To illustrate our present work, we invoke the metaphor of a long-distance trading scenario inspired by the Maghribi Traders Coalition [19] that operated around the 10th century along the North African coast. This scenario describes a collective that relied informal trade arrangements: traders delegated the transport and sale of goods to fellow traders in remote locations under the promise to reciprocate that service, an aspect that allowed them to expand the geographic range of their operations. The essential aspect for our scenario is the reliance on mutual compliance to assure a functioning economic system; individuals that were suspected of embezzling profits, i.e. cheating, faced exclusion from trade. At a later stage, we will complement that society with a counterpart that had to rely on formal institutions to govern compliance, the Genoese traders. They could not rely on a trust network to assure cooperation, but had to resort to contracts in order to sustain a functioning economy. We operationalise those scenarios to provide an accessible evaluation scenario with prototypical institutional configurations, but do not claim to recreate those societies accurately.

In our prototypical societies traders can at the same time adopt two roles: 1) *sender*, and 2) *operator*. Senders send goods to other operators who then facilitate the actual sale (and potentially cheat), and return the realised profits to the sender.

### 3. Norm Representation.

**3.1. Nested ADICO (nADICO).** The concept of Nested ADICO (nADICO) [13] builds on the essential purpose of the original institutional grammar [11] to represent conventions (or shared strategies), norms and rules in the form of *institutional statements*. It consists of five components (with the acronym ADICO), and is briefly explained in the following.

- **Attributes (A)** – describe the characteristics of individuals or groups of individuals that are subject to an institution;
- **Deontic (D)** – indicates whether the institutional statement is of prescriptive or permissive nature. The grammar relies on deontic primitives (e.g. may, must, must not) [46] to express the normative or discretionary nature of a statement. The
- **AI/m (I)** – describes an action or outcome associated with the institutional statement;
- **Conditions (C)** – describe the circumstances under which a statement applies, which can include spatial, temporal and procedural aspects. If unspecified, the applicability is unconstrained and thus implies “at all times and in all places” [11]. Finally, the
- **Or else (O)** – specifies the consequences or sanctions [36] that follow non-compliance with a statement specified by the previous four components. In the nADICO interpretation, consequences can both be attached to social norms and formal rules, whereas the original concept only permits the specification for consequences for rules. The ‘Or else’ itself can be a nested institutional statement.

This grammar allows for the expression of statements of varying nature and strength, representing different institution types, while allowing a straightforward transformation from natural language.

A convention, for example, can be adequately expressed using the components AIC, e.g.:<sup>1</sup> **Traders (A) trade fair (I) when being observed (C)**. Adding the *Deontic* component to the (then ADIC) statement extends it to a sanction-less norm statement: **Traders (A) must (D) trade fair (I) when being observed (C)**. Finally, adding a consequence (*Or else*), constitutes a norm or a rule [13]:<sup>2</sup>

**Traders (A<sub>0</sub>) must (D<sub>0</sub>) trade fair (I<sub>0</sub>) when being observed (C<sub>0</sub>), or else observers**

**(A<sub>1</sub>) must (D<sub>1</sub>) report this (I<sub>1</sub>) in any case (C<sub>1</sub>).**

Institutional statements can be *nested vertically* (as shown above), in which a *consequential statement* (Level 1 on the previous example) backs a statement it monitors (above: ADIC(ADIC)) (here the *monitored statement* on Level 0 in the example). This allows the representation of institutional regress, i.e. the backing of institutions by more deeply embedded institutions that describe monitors’ duties and potential consequences for their non-compliance. In contrast to the original institutional grammar, in nADICO both norms and rules can have specified sanctions. This conception follows the understanding that norms and rules are not so much differentiated by the absence of sanctions, but rather by sanction characteristics. In the case of rule sanctions, prescribed actions, monitoring entities, and enforcers are explicitly specified (i.e. formally appointed). For

<sup>1</sup>In the examples we use parenthesised letters to define the relationship of natural language expressions with the respective grammar component, such as ‘Traders (A)’ referring to the *Attributes* component.

<sup>2</sup>We use indices on statement components to indicate nesting levels (0 being the top level, 1 being the first nested level, etc.).

norms, in contrast, sanctions are characterised by varying/unknown actions as well as fuzzy (and potentially conflated) conceptions of private monitors and enforcers [35].<sup>3</sup>

Ideally this enables the modelling of comprehensive chains of responsibility. Beyond this, institutional statements can be *horizontally nested*, i.e. combined by logical operators that describe their co-occurrence (e.g. ADIC *and* ADIC) or alternative occurrence (inclusive or: ADIC *or* ADIC; exclusive or: ADIC *xor* ADIC). In addition to that, statements can be negated using the *not* operator. *Horizontal Nesting*, as we refer to such co-occurrences, can be used both in the leading monitored statement and trailing consequential statement of a nested institutional statement. The syntax (in the Extended Backus-Naur Form [24]) is defined in Figure 3.1.

```

attributes = "A" ;
deontic    = "D" ;
aim        = "I" ;
conditions = "C" ;
aic        = attributes , aim , conditions ;
adic       = attributes , deontic , aim , conditions ;
and        = "and" ; (* Conjunction *)
or         = "or" ; (* Inclusive Disjunction *)
xor        = "xor" ; (* Exclusive Disjunction *)
not        = "not" ; (* Negation *)
ws         = " " ; (* Whitespace *)
LB         = "(" ;
RB         = ")" ;
nadico     = adic | (* Individual Norm Statement without Sanction *)
            [ not , LB , ( nadico | aic ) , RB ] | (* Negation *)
            [ nadico [ , LB , ( nadico | aic ) , RB ] ] | (* Vertical Nesting *)
            [ LB , ( nadico | aic ) , ws , ( and | or | xor ) ,
              ws , ( nadico | aic ) , RB ] ; (* Horizontal Nesting *)
statement  = aic | nadico ; (* nADICO Statement (including Top-Level Conventions) *)

```

Fig. 3.1: nADICO Grammar Syntax Specification

In nADICO, vertical nesting represents notions of *structural institutional regress*, i.e. the activation of one or more consequential norms upon violation of monitored norm(s).<sup>4</sup> Complementing this, horizontal nesting enables the representation of institutional complexity on a given nesting level. Combining both nesting approaches enables the comprehensive description of individual institutions.

The concept of nested institution levels has previously been discussed by Grossi et al. [20] with focus on the specification of interdependent norm types based on *substantive norms* that are decomposed into *check norms* (that monitor behaviour) and *reaction norms* (that prescribe sanctions associated with violations). López y López et al. [26] propose a similar approach to manage the interdependency between norms. Similar to Grossi et al. they separate norms into primary and secondary norms, but interlock those. The violation of normative goals of secondary norms activates the corresponding primary norms. The nADICO grammar affords the expression of such dependencies in a single comprehensive structural representation. The function of the norm is relative to its nesting level in an institutional statement, guarding a statement on a lower nesting level (i.e. being a consequential statement), while at the same time being guarded by statements on a higher nesting level (i.e. being a monitored statement).

To facilitate the derivation of normative understanding from behavioural feedback, we further utilise a continuous conception of deontics (as opposed to discrete deontic primitives) to reflect the evolution of normative understanding over time and integrate it with the institutional grammar.

<sup>3</sup>This is discussed in greater detail in [13], [14], and [16].

<sup>4</sup>The conventional understanding of institutional regress (as used by Aoki [3] and Hodgson [22]) emphasises the path-dependent formation of institutions over time, an aspect we label as *temporal institutional regress*, in contrast to the structural dependency highlighted by the institutional grammar.



**3.2. Dynamic Deontics.** In place of the institutional grammar’s use of conventional discrete deontic primitives to signify prohibitions, permissions, and obligations, we apply a continuous notion of deontics, previously introduced as Dynamic Deontics [14], which we briefly introduce at this stage. The essential intuitions of this approach are shown in Figure 3.2 and explored in the following.

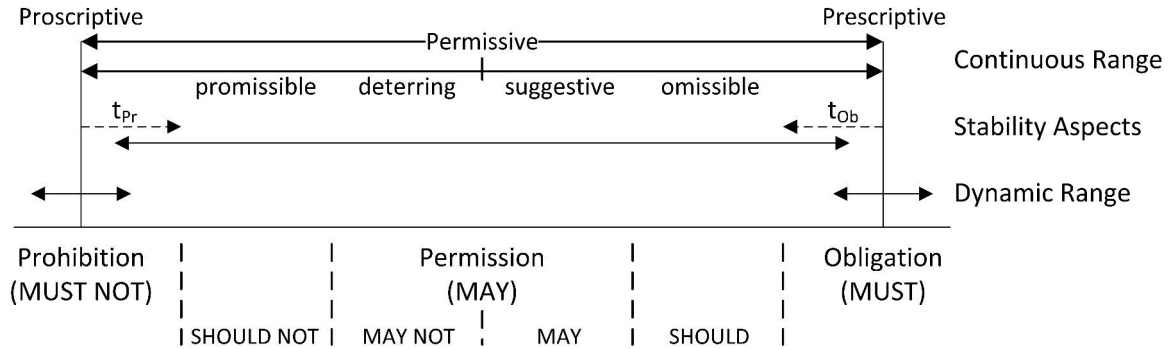

Fig. 3.2: Dynamic Deontic Range

Instead of relying on a simplified discretised representation of normative states, a continuous representation of deontics bridges the gaps between the extremal prohibitions and obligations, reflecting gradual evolving normative understanding over time. Similarly, a continuous conception can reflect the varying notions of oughtness associated with specific prescriptions [7]. Along the continuum between prohibition and obligation, what we conceive as deontic range, we can allocate deontic terms, or *deontics*. The original deontic primitives occupy the extremes and centre point (deontic centre) of the deontic range. To establish basic categories, the deontic range is composed from deontic compartments that carry labels such as *must* and *may*, and indicate relative levels of prescriptiveness,<sup>5</sup> as shown in the ‘omissible’ (obligations that can be foregone) or ‘promissible’ (prohibitions that can be ignored). The range itself is dynamic and determined by the individual’s experience, a possible mapping being the direct association of the most positive and the most negative experiences with the respective ends of the deontic range.

To operationalise this approach, we rely on reinforcement learning, or more specifically, Q-Learning [47]. It offers the direct representation of extremal reinforcements (highest and lowest Q-values) as well as discounting of reinforcements over time, operationalising features such as the expansion and contraction of the deontic range.

In the context of this work, Dynamic Deontics are used to develop normative associations with specific actions (e.g. developing the understanding that one is *obliged to trade fair* and *prohibited from cheating*). Along with this, we maintain sliding windows of past extremal (i.e. positive and negative) reinforcements to smooth the dynamics of the deontic range, from which deontic compartments are dynamically derived. For a detailed account on the involved operational steps refer to [16].

**4. From Experiences to Institutions.** Although conventions and norms surround us, we are often barely conscious of their existence and origin. Generally, norms implicitly emerge on the basis of experiential [33] and social [4] learning in the contexts of existing institutions [49], whereas rules are explicitly specified [32], which allows their unambiguous communication and adoption.

To model the subconscious processes of evolving institutional understanding, we employ a data-driven approach that utilises the data structures we have described to facilitate agents’ understanding of the normative environment involving a minimal amount of explicit reasoning. In addition, the operationalisation proposed here aims to be generalisable, operates decentralised (i.e. without a central coordinating entity), and relies on a minimal amount of prior information. To achieve this, in Subsection 4.1 we operationalise an institution

<sup>5</sup>Note that the choice of intermediate deontic terms for this example is not systematically grounded but is chosen with analogy to other fields, such as the keywords for requirements specification in *Request for Comment* (RFC) documents [8] by the Internet Engineering Task Force.

representation that has the descriptive power to capture individual actions (action instances) as well as higher-level institutions. Based on those principles, we present a systematic process that describes the transition and derivation of institutional statements from individual observations (Subsection 4.2 onwards).

**4.1. Action Representation.** To operationalise actions, we use the syntax of the nADICO grammar’s AIC component that augments an action definition ( $AI_m$ ) with the subject ( $Attributes$ ) and context/conditions ( $Conditions$ ). Utilising the term **act** to identify an individual action instance (as opposed to an institutional statement of the form **aic**), an *action statement* is thus **act(attributes, aim, conditions)**, where **aim** represents the action definition.

*Attributes.* Operationalising the  $Attributes$  component, we assume that individuals carry observable properties reflecting the notion of social markers individuals display in real life [43], such as name, ethnic background, gender, etc. Such markers can be of individual nature (i.e. attached to the personal identity) and social character (i.e. one’s social identity), and be temporary and/or modifiable (e.g. clothing, situational role), or permanent (e.g. physical features). For the context of this work we represent attributes as two sets, with the first set  $i$  representing individual characteristics and the second one ( $s$ ) highlighting group features [21], providing the generic structure **attributes(i, s)**. To facilitate the differentiated treatment of attributes as part of the generalisation process, we assume that individuals are able to categorise social markers by their natural kind, such as ‘role’, ‘occupation’, ‘origin’, as opposed to treating those as unstructured tags as done in previous work [15]. The essential advantage of categorising markers is the ability to account for asymmetric sets of markers, but also to permit refined characterisations by permitting combinations of markers (e.g. multiple occupations).

Individual and social markers are represented as key-value pairs  $\langle k, v \rangle$ , where the key  $k$  represents a unique label<sup>6</sup> that describes a relevant category (e.g. **occupation**), and the value  $v$  is the set of associated markers (e.g. **trader**). Consequently, individual and social markers are sets of such pairs, as exemplified in the Figure 4.1.<sup>7</sup>

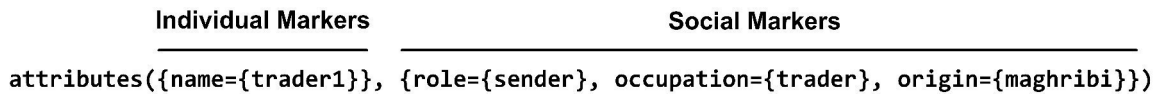

Fig. 4.1: Attributes Structure

*Actions.* To establish unambiguous symbolic references to an action and its properties, we require a structured action specification. We define actions using a label  $a$  and an associated set of properties  $p$ , the set of which depends on the nature of the action. Substituting the  $AI_m$  component of the institutional grammar, we can thus say **aim(a, p)**. Taking an example from our scenario, the central properties of the action ‘send goods to trader’ are the *object* that is dispatched (‘goods’), as well as the destined *target* (‘trader’). This *action definition* can thus be represented as **aim(send, {object, target})**, and instantiated as **aim(send, {goods, trader})**. Note that the representation shown here simplifies the  $Attributes$  component by substituting the trader’s complete attribute specification with the token ‘trader’.

*Conditions.* In addition, we tailor the  $Conditions$  component to capture the context of action execution by allowing the specification of a potentially related preceding action (e.g. as a reaction to a previous action) as the first element in order to represent action sequences, or behavioural regularities that can be precursors for identified institutions.

Table 4.1 provides an overview of the operationalised component specifications.<sup>8</sup>

**4.2. Generalisation.** Individuals generally and unintentionally engage in processes of ‘implicit social cognition’ [18], one of which is the social generalisation process of ‘stereotyping’. Stereotyping attributes individual observations of behaviour or features to social structures generalised from observation instances. As such this

<sup>6</sup>Note that the label does not need to carry any semantic weight other than uniquely identifying a given category.

<sup>7</sup>For the sake of brevity the value sets in our example only contain individual values.

<sup>8</sup>To keep expressions concise, for given examples the complete attributes specification of agents (i.e. their social markers) is substituted with their name (e.g. **trader1**).

Table 4.1: Component Specifications

Component	Structure	Example/Instance
Attributes	<code>attributes(i, s)</code> , with <code>i/s</code> being sets of individual/social marker pairs	<code>attributes({name={trader1}}, {role={sender}}, occupation={trader}, ethnicity={maghribi})</code>
Action Definition	<code>aim(a, p)</code> , with <code>a</code> being a natural language action descriptor, and <code>p</code> being a set of action properties	<code>aim(send, {object, target})</code>
Conditions	<code>conditions(act, c)</code> , with <code>act</code> being a preceding action, and <code>c</code> being a set of further conditions	<code>act(trader2, aim(trade, {goods}), conditions(act(trader1, aim(send, {goods, trader2}), *)))</code>
Action Statement	<code>act(attributes, aim, conditions)</code>	<code>act(trader1, aim(send, {goods, trader2}), *)</code>

process bears similarities to inductive reasoning, but in contrast to the latter, stereotyping occurs subconsciously and does not consider explicit probabilistic reasoning. Notwithstanding the disputed underlying causes for its existence and attributed oversimplification in social contexts, this process can lead to uncertainty reduction and efficiency enhancement, effects that are characteristic for institutions [31, 50]. Since stereotyping builds on the assumption that actors repeat previously displayed behaviour, it enables individuals to develop predictors to anticipate others' behaviours and to call upon previously executed successful reactions. This specific aspect makes consideration of stereotyping important when modelling institutional evolution, since it provides the mechanism that links agents' minds with their environment, shaping *beliefs* from presumed *habits*, or as Peirce [34] put it: “[the] essence of belief is the establishment of habit.” In a similar vein, Castelfranchi links these conceptions by suggesting that minds themselves are social institutions [9].

Apart from the resemblance of human behaviour in agents, adopting this approach for artificial agents minimises the cognitive load for agents, limiting the need for complex agent architectures, and, along with this, potentially the demand for computational resources.

Following this understanding, the proposed mechanism operates entirely based on collected action instances as specified above. As highlighted in the individual transitions in Figure 4.2, the collected action instances are generalised into *descriptive norms* (or conventions), before aggregating associated experience to produce *valenced expressions*, which are used to generate *injunctive norms*.<sup>9</sup> In the following we provide a detailed description of these individual steps.

Modelling subconscious generalisation processes shifts the perspective from the observation of *individual behaviour instances* to the inference of *social behavioural regularities*, narrowing the gap to what we perceive as institutions. We thus perform an aggregation of individual action statements to form generalised AIC statements, which we consider equivalent to observed conventions, or, in this case, *descriptive norms*. Operationally we achieve this by grouping the observed action statements based on their individual components.

To explore this generalisation process, let us use a running example, a trade action instance. `trader2` trades goods in the role of an `operator`, after having been sent goods by another fellow trader `trader1` (in the role of a `sender`):

<sup>9</sup>*Descriptive norms* describe how norm participants behave, whereas *injunctive norms* specify how norm participants should behave [10].

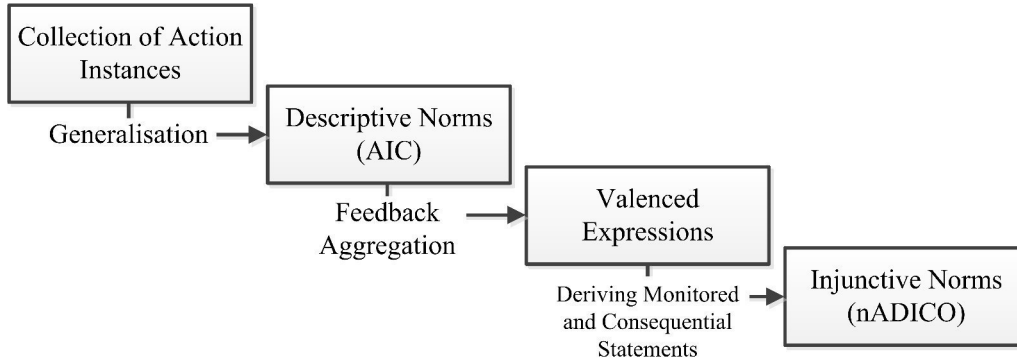

Fig. 4.2: Generalisation Process

```

act(attributes({name={trader2}}, {role={operator}, occupation={trader},
              ethnicity={maghribi}}),
    aim(trade, {goods}),
    conditions(act(attributes({name={trader1}}, {role={sender},
                            occupation={trader}, ethnicity={maghribi}}),
                  aim(send, {goods, attributes({name={trader2}},
                                                {role={operator}, occupation={trader},
                                                ethnicity={maghribi}})}),
                  conditions(*))))
  
```

Focal statement components with relevance for the generalisation of behavioural conventions or norms from individual observations include the *actor* (**attributes** component) and the *action* (**aim** component).

In an initial step, all observations are grouped by the action descriptor, ignoring additional action properties. In our running example this resolves to the action **trade**. In the resulting action statements we ignore the individual markers but concentrate on the aggregation based on social markers, i.e. markers that are shared among multiple individuals/groups.

The generalisation of grouped action statements can be attacked from two perspectives, one being the identification of *differences* among individual action instances in order to infer behavioural regularities that are specific to particular roles as described in [15].

An alternative is to approach generalisation from a bottom-up perspective by concentrating on *similar features* to identify behavioural regularities on different social aggregation levels. Let us exemplify this approach using a more realistic set of individual observations shown in Figure 4.3.

```

attributes(*, {role={sender},    occupation={trader},    origin={maghribi}})
attributes(*, {role={sender},    occupation={trader},    origin={maghribi}})
attributes(*, {role={operator},  occupation={trader},    origin={maghribi}})
attributes(*, {role={sender},    occupation={trader},    origin={genoese}})
attributes(*, {role={potter},    occupation={artisan},   origin={maghribi}})
  
```

Fig. 4.3: Observation Samples for Hierarchical Generalisation

To model more complex multi-level generalisation processes, we are inspired by agglomerative hierarchical clustering [25], i.e. the generation of clusters of decreasing granularity by incrementally increasing permissible distances of clustered elements. For the context of our work, we group individual observations based on their shared attribute categories/features, before incrementally reducing the number of shared categories to establish more coarse-grained generalisations that cluster wider ranges of observations.

The initial grouping of observations operates on all attributes features of given observations. We refer to this as **Level 0 Generalisation**, since it does not permit deviating attribute values in aggregated statements. Using the observation samples listed in Figure 4.3 we can group two observations on **Level 0**,<sup>10</sup> with all other observations being unique with respect to their attribute sets as shown in Figure 4.4. For the sake of conciseness we only show combinations with at least two matching statements.

<b>Level 2</b>	<b>{role=*, occupation={trader}, origin=*} (4),</b> <b>{role=*, occupation=*, origin={maghribi}} (4),</b> <b>{role={sender}, occupation=*, origin=*} (3)</b>
<b>Level 1</b>	<b>{role=*, occupation={trader}, origin={maghribi}} (3),</b> <b>{role={sender}, occupation={trader}, origin=*} (3),</b> <b>{role={sender}, occupation=*, origin={maghribi}} (2)</b>
<b>Level 0</b>	<b>{role={sender}, occupation={trader}, origin={maghribi}} (2)</b>

Fig. 4.4: Hierarchical Generalisation

To model higher-level generalisations, we permit an increasing distance of observations. We operationalise the distance between observations as number of deviating category values, since our action representation operates based on nominal features. A **Level 5 Generalisation** would thus capture observations in which five features differ. A scenario consisting of  $n$  attribute categories thus permits a maximum generalisation level of  $n - 1$ , i.e. requiring at least one shared feature. In a scenario with six features the **Level 5 Generalisation** would represent the most coarse-grained generalisation.

Shifting to **Level 1**, we consequently permit a single deviating feature between attributes of statements considered for generalisation. From the sample set of five observations, **Level 1 Generalisation** results in three generalised attribute sets, one capturing all *Maghribi traders* and the second one describing *traders that operate as senders (of goods)*, as well as *Maghribi senders*.

Permitting **Level 2 Generalisation**, we cluster observations that showcase two deviating features. For our sample case, we extract three generalised attribute sets, *traders*, *Maghribis*, and *senders*.

Even though a uniform characterisation of attributes appears desirable, the established generalisations do not conflict, but reflect multiple possible perspectives of generalisation. The relevance of whose can potentially be determined by the number of observations captured, as well as the aggregated reinforcements of the associated actions that indicate the salience of behaviour (i.e. the extent to which all observations associated with this generalisation actually describe uniform behaviour), an aspect discussed in the upcoming Subsection 4.3.

Returning from the generalisation of attributes to the extraction of generalised observations, let us summarise the involved individual steps.

With  $S_{acts}$  being the collection of all individual observation action statements,  $S_{aims}$  being the individual aims, and the functions

- $attr(act)$  extracting a given action statement's ( $act$ ) attributes, or all attribute components from a set of action statements, and
- $aim(act)$  extracting a given action statement's aim,

we can formalise the generalisation process as shown in Algorithm 1.

Initially all observations are grouped by the action they describe (**aim**), followed by the generalisation process that identifies intersections of attributes on different aggregation levels. The data structures keep track of the number of observations that back a generalised statement. This generalisation process operates across all attributes occurrences in observation statements, including attributes of preceding actions in the **conditions** component of an action statement.

This generalisation process marks the initial step of deriving normative understanding from individual observations in the form of descriptive norms, or conventions (AIC statements in nADICO (see Subsection 3.1).

<sup>10</sup>The number of captured observations per generalised attribute set is shown in parentheses.

**Algorithm 1** Hierarchical Generalisation Algorithm

---

```

1: Initialise set Obs (observations grouped by aim);
2: Initialise set  $Gen_{(aim,level)}$  (generalised observations for aim aim and level level);
3: // Group action statements by aim
4: for aim in  $S_{aims}$  do
5:   for act in  $S_{acts}$  do
6:     if  $aim(act) == aim$  then
7:       Add act to set  $Obs_{aim}$  (Observations related to aim aim) contained in Obs;
8:     end if
9:   end for
10: end for
11: // Generalise grouped observations
12: for  $Obs_{aim}$  in Obs do
13:   Remove individual markers;
14:   // Determine maximum cluster distance based on number of attribute categories for observations
   grouped by action aim
15:    $maxDist = \max(attr(Obs_{aim})) - 1$ ;
16:   // Determine generalised statements for all feature distances
17:   for distance in  $maxDist$  do
18:      $level = maxDist - distance$ ;
19:     // Identify intersections of size level among attributes of grouped observations for action aim
     and save generalised statements
20:      $Gen_{(aim,level)} = \{x \in attr(Obs_{aim}), length(x) = level\}$ ;
21:   end for
22: end for
23: // At this stage  $Gen_{(aim,level)}$  contains generalised observations for all aims and all levels

```

---

From the perspective of the observing agent, this generalised understanding describes *how* agents in his social environment behave – independent of how they *should* behave.

Recalling the example provided at the outset of this subsection the generalisation process produces the following aic statement:

```

aic(attributes({role={operator}, occupation={trader}, ethnicity={maghribi}}),
  aim({action={trade}}, {object={goods}}),
  conditions(aic(attributes(*, {role={sender},
    occupation={trader}, ethnicity={maghribi}}),
    aim({action={send}, {object={goods}, target={
      attributes(
        {role={operator}, occupation={trader},
          ethnicity={maghribi}})})),
    conditions(*))))

```

From a normative perspective this translates into the understanding that ‘Maghribi traders in operator roles trade goods after having been sent goods by Maghribi traders acting as senders’.

In order to develop more complex institutional statements, beyond conventions or objectified descriptive norms, we need to assume that agents receive and associate feedback with individual action instances as part of their experiential learning process. This is not only important to develop a understanding of ‘oughtness’, as introduced in conjunction with the Dynamic Deontics conception (see Subsection 3.2), but also to support the evaluation of generalisation outcomes with respect to their contextual relevance as discussed in this subsection.

Any such feedback serves as input for a second aggregation process that converts the feedback into normative understanding. The conceptualisation and implementation of feedback naturally depends on the application scenario.

**4.3. Feedback Aggregation.** The central purpose of the feedback aggregation process is to build up information used for an agent’s overall understanding of a generalised convention. This is not to be confused with its attitude towards that convention, but instead represents the result of cyclic internalisation and socialisation processes that make agents experiential learners and shape their normative understanding, while, by means of

Table 4.2: Exemplified Action Instances with Valences

Simplified Action Example	Feedback
<code>act(attributes({name={trader1}}, {...}), aim(action={trade}), ...)</code>	30
<code>act(attributes({name={trader2}}, {...}), aim(action={trade}), ...)</code>	10
<code>act(attributes({name={trader3}}, {...}), aim(action={trade}), ...)</code>	-20
<code>act(attributes({name={trader4}}, {...}), aim(action={trade}), ...)</code>	20

conforming to normative behaviour, becoming enforcers in their own right. This aggregation operates on the action instances associated with a corresponding AIC statement as introduced in the previous Subsection 4.2. Table 4.2 shows (simplified) action instance observations for the action `trade`, along with hypothetical feedback values.

To derive an aggregated feedback, or *deontic value*, that is to be attached to the generalised institutional statement, we consider various *aggregation strategies*.

Since the purpose of this work is centred around the process of deriving institutional understanding from behaviour, as opposed to applying it to a specific scenario or types of agents, we concentrate on the rational strategy. The *rational aggregation strategy* is the purest analytical approach to deriving normative understanding, since it is based on the mean of all input values to determine a rationally expected feedback for future occurrences of a given action. Applying the rational deontic aggregation strategy, the exemplified observation sample in Table 4.2 would result in an aggregate feedback value (or *deontic value*) of 10. Recalling the deontic range conceptualisation discussed in Subsection 3.2, we can map this numeric value into an obligation, prohibition or permission that the individual associates with the evaluated action.

A (non-exhaustive) set of alternative possible strategies include the *opportunistic strategy*, in which individuals focus on extremal accounts of the most desirable or feared outcome (resolving to 30 for the sample in Table 4.2), as well as *optimistic* and *pessimistic* strategies that emphasise a bias towards best possible or worst possible outcomes (i.e. resolving to 30 and -20 respectively). The informed choice of those strategies can be used to express personal characteristics, such as a positivity or negativity bias [5] of individuals, but also to reflect cultural predispositions such as risk avoidance [23] when evaluating normative behaviour. The operationalisation of the mentioned alternative aggregation strategies is described in [16].

In preparation for the final step of this process of norm identification, the aggregated value – determined based on strategies discussed in this subsection – is associated with the generalised AIC statement as a precursor for the development of nADICO statements. For this purpose we rely on the concept of Dynamic Deontics to operationalise nADICO’s *Deontic* component.

**4.4. Deriving nADICO Expressions.** To derive higher-level nADICO expressions from AIC statements, we revisit the developed action sequences that not only reflect an individual’s actions but also multi-party actions. Actors can be generalised based on their social markers, such as roles (e.g. sender of goods, recipient, etc.). Consequently, agents do not only generate behavioural conventions that consider themselves or only of roles they play. In principle, individuals can form an institutional understanding about any role (or, more precisely, set of social markers) they observe, and use this knowledge predict unknown individuals’ behaviours based on their social markers. This satisfies an important purpose of institutions, the reduction of uncertainty [31], based on the ability to predict normative behaviour using the stereotypes attached to the observed individual. The data-driven mechanism to develop normative understanding introduced up to this stage gives agents the ability to generalise and abstractly observe different role perspectives, both of which are precursors for applying cognitive empathy [12], such as the ability to perform perspective taking.

However, to translate observed action instances from a mere descriptive (AIC statements) to a prescriptive perspective (ADIC/nADICO statements), we require the transformation of action sequences by *separating* those into *monitored statements* and *consequential statements* (see Subsection 3.1) as well as the assignment of deontic values.

In the following we describe the elementary steps involved in deriving nADICO statements, which include:

- Identification of monitored and consequential statements
- Assigning the deontic value to the monitored statement
- Inverting the deontic value and assigning it to the consequential statement

*Identifying Monitored and Consequential Statements.* In the course of their interaction, individuals collect action sequences, i.e. actions along with preceding actions, expressed as **act** statements with a subsequent **act** statement's **conditions** component (see Subsection 4.1). These action sequences represent action/reaction pairs that describe a 'because of', or 'on the grounds of' relationship, reflecting a direct causal dependency between both actions. Using our running example we would then arrive at the interpretation: "The Maghribi operator trades goods *because* he has been sent goods by the Maghribi sender.", which represents the descriptive norm perspective directly derived from observed behaviour. However, to represent an injunctive perspective that highlights an individual's perception of its duties [10], we require the transformation into '*Or else*' relationships for cases in which multiple actions occur in sequence. An example of such generalised action sequence is the initial statement '*Sender* sending goods', followed by '*Operator* trading goods.'. To reflect the injunctive nature of the '*Or else*', we attach textual representations of perceived duty (deontics) to the individual statements and *invert* the derived consequential statement's deontic ('Senders *have to* send goods, or else Operators *will NOT* trade goods.'). As discussed in Subsection 3.2, note that the deontic terms associated with the deontic range (*may, should, must*) may not precisely reflect this understanding, but they capture the intuition of varying levels of duty.

To proceed along these lines, it is necessary to identify action sequences that involve one's social environment, i.e. multi-party interactions. Operationally, starting from the last element in the action sequence (i.e. the most recent action), the agent iterates backwards through the action sequence and identifies the first action statement whose attributes (i.e. generalised social markers) differ from the final action statement's attributes. The subsequence of all remaining action statements is then treated as *monitored statement* (i.e. the statement whose compliance is monitored), whereas the sequence of all parsed action statements is interpreted as *consequential statement*. Let us use the following example to explore these mechanics: '*Senders* send goods', followed by '*Operators* cheating', followed by '*Senders* firing them'. Working our way backwards from the last statement ('*Senders* firing them'), we find that the second last statement has a differing generalised actor (*Operators*), leaving us with the monitored statement '*Operators* cheat after *Senders* sending goods' and the consequential statement '*Senders* firing them'.

If an action sequence *does not* include multiple parties, i.e. all actions are performed by a single individual (or multiple individuals carrying identical social markers), the last elementary action is then interpreted as the previous action's consequence and treated as *consequential statement*, with the preceding action statements being the corresponding *monitored statement*.

*Assigning Deontic Value to Monitored Statement.* To give the statements normative value, we utilise the aggregated deontic value for the entire action sequence derived as part of the previously described feedback aggregation step (Subsection 4.3) and assign it to the identified monitored statement's *Deontic* component.

*Assigning the Inverted Deontic Value to the Consequential Statement.* Finally, to establish a deontic term's corresponding counterpart (e.g. *should* vs. *should not*), we rely on the individual's existing deontic range to invert the aggregated value. The inversion involves the proportional mapping of deontic values along the individual's deontic range to the inverted deontic compartment. The resulting deontic value is assigned to the consequential statement to express the presumed consequence for the violation of the inferred monitored statement. For example, assuming a deontic range with midpoint value of 0, a value of 5 – possibly mapping to *should* – is inverted to its opposite scale value and deontic term (*should not*) as schematically visualised in Figure 4.5. Note that the assumption of a symmetric deontic range is an exemplary simplification.<sup>11</sup>

<sup>11</sup>Alternative configurations are discussed in [16].



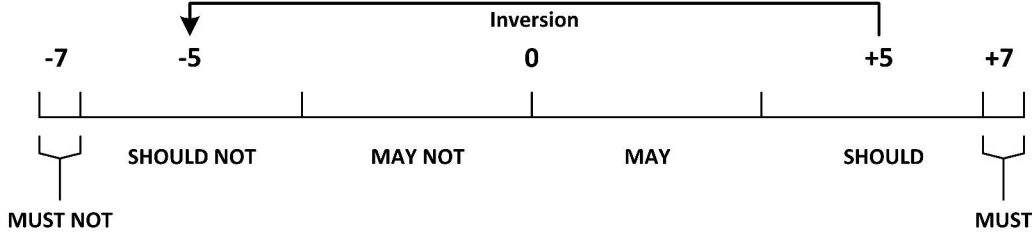

Fig. 4.5: Exemplified Deontic Inversion Process

Applying the deontic inversion to our running example, the corresponding nADICO statement reads:

```
adico(attributes({role={sender}, occupation={trader}}),
  deontic(5),
  aim(action={send}, {object={goods}, target={attributes(
    {role={operator}, occupation={trader}})})),
  conditions(*),
  orElse(adico(attributes({role={operator}, occupation={trader}}),
    deontic(-5),
    aim(action={trade}, {object={goods}}),
    conditions(*))))
```

Let us summarise the individual steps in algorithmic form.

Using  $adic_k$  to describe an individual action statement at the  $k$ -th position within a sequence of statements  $(adic_k)_{k=1}^{max}$  (with the first statement being the last performed action and  $max$  indicating the total number of action statements in the sequence), we can derive the corresponding nADICO statement  $nadico$  and define the associated monitored statement (Function  $nadic(nadico)$ ) and consequential statement (Function  $o(nadico)$ ) as described in Algorithm 2.

In the context of the derivation of nADICO statements, it is important to highlight a special case. This derivation approach does not establish a consequential statement if no previous action has been observed, generating an injunctive norm without specified consequences, e.g. an obligation or prohibition without consequence. This corresponds to an ADIC statement in the nADICO syntax.

At this stage, the derived nADICO statements provide the experimenter with a comprehensive insight into individuals' experience-based normative understanding. The derived statements can be further generalised based on individual grammar components, such as

- *actions (Aims)* – by inferring an overall normative understanding of actions from aggregated nADICO statements – and
- *social structures (Attributes)* – by generalising normative behaviour for specific actor stereotypes (e.g. roles) on multiple generalisation levels (e.g. by occupation, by origin, etc.).

However, as in reality, this mechanism can only operate on action sequences known to an agent, i.e. actions an agent actually perceived. To afford the representation of deceitful behaviour and the associated information asymmetry, we assume that some actions are performed internally without being directly accessible to outside observers. Agent can thus perform more actions than can be perceived by observers. An example is the action of cheating, which may well be internalised by the cheating party, but will not be visible to the subject of cheating. Operationally, agents achieve this by internally maintaining action sequences that include the private actions they performed in addition to the publicly visible ones. The generalisation process itself is indifferent about the public or private nature of action statements in action sequences and operates on whichever statements have been perceived by the individual agent, potentially leading to an information asymmetry between the cheater (who knows he cheated) and the unknowing observer.

At this stage we will explore the introduced mechanism using the simulation scenario described at the outset of this article.

**Algorithm 2** nADICO Statement Derivation Algorithm

---

```

1: // 1 is last (i.e. latest) statement in sequence, max is first (oldest)
2:  $k = 1$ ;
3: if  $max == 1$  then
4:   // Only one statement in sequence
5:   // Assign monitored statement
6:    $nadic(nadico) = adic_1$ ;
7:   // Assign aggregated feedback value (see Subsection 4.3) as monitored statement's deontic
8:    $d(nadic(nadico)) = d((adic_k)_{k=1}^{max})$ ;
9: else
10:  // More than one statement in sequence
11:  // Iterate backwards until attributes in statements differ
12:  while  $a(adick) == a(adick_{k+1})$  &  $k < max$  do
13:     $k++$ ;
14:  end while
15:  if  $k == max$  then
16:    // Make last statement consequential statement if no deviating attributes found
17:     $k = 1$ ;
18:  end if
19:  // Assign subsequence from last (i.e. most recent) action statement to action statement k as
    consequential statement
20:   $o(nadico) = (adic_l)_{l=1}^k$ ;
21:  // Assign all other action statements as monitored statement
22:   $nadic(nadico) = (adic_l)_{l=k+1}^{max}$ ;
23:  // Assign aggregated feedback value (see Subsection 4.3) as monitored statement's deontic
24:   $d(nadic(nadico)) = d((adic_k)_{k=1}^{max})$ ;
25:  // Assign the inverted deontic to consequential statement
26:   $d(o(nadico)) = inv(d(nadic(nadico)))$ ;
27: end if

```

---

**5. Simulating Normative Understanding amongst Maghribi Traders.** The Maghribi trader society highlighted in the beginning of this article provides an example of a medieval society that flourished based on informal cooperation – without the use of existing centrally enforceable institutional instruments (such as contracts). The mechanism described in this work thus bears characteristics that are compatible with this prototypical scenario, that is the decentralised nature, the informal normative perspective, and the purist approach towards inference of norms from experience and observation. We use this scenario to highlight the features of this approach, specifically the ability to inspect agents' minds individually, but also to develop an understanding of the collective normative landscape. Instead of exploring the test scenario comprehensively, we explore distributions of non-/cooperative behaviour under which general economic cooperation can be sustained, but more importantly, how it is reflected in the emerging normative understanding.

Traders, potentially acting as **sender** and **operator** establish a maximum number (*maxRelationships*) of mutual trade relationships to other traders based on random requests, to which they then send goods. The receiver trades those goods at a profit that is determined by a fixed factor *profitFactor*.<sup>12</sup> If initialised as cheater, the trader cheats by embezzling a fraction of the profit (as described below) and returns the remainder to the original sender. Sending agents memorise a parameterised number of last returned profits (as action feedback), which they can query for specific individuals or across all their partners in order to decide on the correctness of the returned profit. In cases of presumed cheating, traders can fire the suspect and memorise it as a cheater, or reward it with *wageFactor* of the generated profit. The interactions represent actions of the structure introduced in Subsection 4.1, with preceding actions stored in the *Conditions* component, successively building up action sequences that represent the comprehensive transactions between individual agents.

To reflect the ongoing trade relationship, rewards are represented as the accumulated profit from previous interactions with the rewarding party (i.e. the profits a respective trader had generated for the service provider over time). If the operator's cheating was not detected, the cheater adds the embezzled fraction as part of his

---

<sup>12</sup>We use a fixed factor since it simplifies the detection of cheating. The focus of this work does not lie in the evaluation of an agent's ability to detect cheating, but to understand the impact of cheating on the emerging normative understanding produced by the generalisation process.

reward from a trade interaction. In the case of firing, the fired trader memorises the inverted trade value and associates it with the action sequence.

For each transaction agents generate corresponding action sequences. To represent deceitful actions, agents maintain private actions which they include in their internalised action sequences in addition to the overtly observable actions, as alluded to in Subsection 4.4. If an operator cheats, he internalises the action ‘cheating’ (in addition to ‘trading’) but merely indicate that he traded the goods. He can then monitor this action sequence and internalise if his cheating (in combination with trading) was successful. Another case is the suspected cheating (from the perspective of the original sender of the goods). If suspecting cheating by an observed agent, the original sender can add the private action ‘cheating’ to his internalised action sequence of the observed individual without sharing this suspicion.

Based on their experience agents derive normative statements as outlined in the previous sections. Traders can query the derived statements to guide their decisions whether to continue sending goods by aggregating deontic values for given actions (e.g. sending goods) across one’s overall experience. Given our characterisation of norms as continua, agents stop committing to actions such as ‘sending goods’ as soon as those actions appear undesirable from a normative perspective. Using the labels of the prototypical deontic range (see Subsection 3.2), this would be the case if such actions are associated with the deontic compartments *may not*, *should not*, or *must not*. However, instead of having agents rigidly act according to those compartments, we introduce an element of randomness. To achieve this all deontic values are normalised across the deontic range (i.e. lowest deontic value to 0 (*must not*), deontic centre as 0.5 (neutral), and highest deontic value as 1 (*must*)). Those normalised values are then used as input probabilities for the random number generator to determine whether the behaviour is performed (and economic transactions sustained). Defecting from performing such actions naturally limits market interactions if they are deemed normatively undesirable. In consequence, this affects the overall economic performance, with the best possible case being complete market participation, and the worst case being the breakdown of any market activity. The notion of normalised deontic values is likewise used to determine the fraction of embezzled profits – the embezzled fraction increases with the internalised normative desirability of cheating.

Algorithm 3 outlines the agents’ execution cycles described in the previous paragraphs; Algorithm 4 specifies agents’ reactions to possible types of incoming requests (which are marked as different ‘cases’).

---

### Algorithm 3 Agent Execution Cycle

---

```

1: if < maxRelationships relationships to other traders then
2:   Pick random another trader this agent does not have relationship with and send relationship
   request;
3:   if request is accepted then
4:     Add accepting trader to set of relationships;
5:   end if
6: end if
7: if agent has relationships to other traders then
8:   Pick random fellow trader from set of relationships;
9:   Determine random Boolean to decide whether to send goods (using normalised deontic
   value for action ‘send goods’ as probability);
10:  if sending goods then
11:    Send goods to selected trader and await return of profit;
12:    if profit < 0 and mean value of memorised past transactions from trader is < 0 then
13:      Extend received action statement with action cheat;
14:      Memorise trader as cheater;
15:      Fire trader;
16:    else
17:      Reward trader by paying a reward of wageFactor * profit;
18:    end if
19:    Memorise action statement in association with profit;
20:  end if
21: end if
22: Derive nADICO statements from memory;

```

---

**Algorithm 4** Agent Reactions

---

```

1: Initialisation: Initialise agent as cheater with probability  $p_{cheater}$ ;
2: Case 1: Receipt of Relationship Request
3: if requester is not memorised as cheater and  $< maxRelationships$  relationships then
4:   Accept request and add requester to relationships;
5: else
6:   Reject request;
7: end if
8: Case 2: Receipt of Trade Request
9: Perform market transaction (goods' value *  $profitFactor$ );
10: if initialised as cheater then
11:   Determine fraction  $f$  of profit to embezzle as normalised deontic value for action 'cheating'
      ( $0 < f \leq 1$ );
12:   Create private copy of action statement and add action cheat;
13:   Memorise extended action sequence;
14: end if
15: Return (remaining) profit to sender;
16: Case 3: Receipt of Firing Notification
17: Remove sender from own relationships;
18: Mark sender as cheater;

```

---

**6. Evaluation.** Turning to the evaluation, we develop a baseline scenario (Subsection 6.1) in order to understand how the generalisation mechanism can be operationalised. Following this, we modify the parameter set of the base model by introducing cheating (Subsection 6.2) and analyse how this affects the overall simulation outcome. As a third step, we change the composition of the artificial society to see the impact of changing social structures on the emerging normative understanding (Subsection 6.3), before exploring the generalisation of norms beyond the observed actor characteristics as a precursor for predictive capabilities (Subsection 6.4).

**6.1. Establishing Normative Understanding in the Base Scenario.** We initialise the simulation with the base parameter set outlined in Table 6.1, one of which we vary in the course of the evaluation. Since our intent is to measure economic cooperation, we use the number of performed transactions per round as a target variable to indicate overall economic performance. With the exception of the  $wageFactor$  that is derived from documented profit distributions in commenda relationships [44], the chosen parameter set has not been empirically explored. Instead it is initialised to produce return for both sender and operator in the case of cooperative interaction to show how such outcomes are reflected in the generated normative understanding, without assuming an accurate representation of historical happenstance.

Table 6.1: Simulation Parameters

Parameter	Default Value	Variation in Section
Number of Agents	50	
$maxRelationships$	20	
$profitFactor$ (Factor of Goods' Value)	1.3	
$wageFactor$ (Factor of Total Profit)	0.33	
$p_{cheater}$ (Fraction of Cheaters)	0	Subsection 6.2
Deontic Aggregation Strategy	Rational	
Number of Profit Memory Entries	100	
Number of Cheater Memory Entries	10	

Running a base scenario without any cheating we can establish the maximum level of cooperation, that is 100 transactions per simulation round. In this scenario each agent is involved twice per round, once for sending goods to initiate trade by another agent, and once for returning goods to the original sender. For all simulation runs we evaluate the emerging normative understanding after 1000 rounds, a period after which behaviour stabilised in all simulation scenarios.

In the base scenario the absence of cheaters offers limited surprise. However, it is a good starting point to identify how our generalisation mechanism translates individual agents' observations into normative understanding at large. Inspecting an individual's traces in Figure 6.1, we can identify the situational deontic range boundaries as well as the generated nADICO statements.

		<b>Situational Deontic Range</b>
MUST NOT: -13.730727; SHOULD NOT: to -6.8653636; MAY NOT: to -0.6865364 INDIFFERENT: to 1.405492 MAY: to 14.054919; SHOULD: to 28.109838; MUST: 28.109838		
<b>1</b>	L0: A=A(*, {ROLE=[ <b>OPERATOR</b> ], ORIGIN=[MAGHRIBI], OCCUPATION=[TRADER]}), D=13.750001 ( <b>MAY</b> ), I=I( <b>RETURN_PROFIT</b> , *), C=C({PREVIOUS_ACTION=L0: A=A(*, {ROLE=[ <b>OPERATOR</b> ], ORIGIN=[MAGHRIBI], OCCUPATION=[TRADER]}), I=I( <b>TRADE</b> , *), C=C({PREVIOUS_ACTION=L0: A=A(*, {ROLE=[ <b>SENDER</b> ], ORIGIN=[MAGHRIBI], OCCUPATION=[TRADER]}), I=I( <b>SEND_GOODS</b> , *), C=C(*), O=(null)), O=(null)), O=(L1: A=A(*, {ROLE=[ <b>SENDER</b> ], ORIGIN=[MAGHRIBI], OCCUPATION=[TRADER]}), D=-6.716421 (inv) ( <b>MUST NOT</b> ), I=I( <b>REWARD</b> , *), C=C(*), O=(null))	
<b>2</b>	L0: A=A(*, {ROLE=[ <b>SENDER</b> ], ORIGIN=[MAGHRIBI], OCCUPATION=[TRADER]}), D=27.916664 ( <b>MUST</b> ), I=I( <b>SEND_GOODS</b> , *), C=C(*), O=(L1: A=A(*, {ROLE=[ <b>OPERATOR</b> ], ORIGIN=[MAGHRIBI], OCCUPATION=[TRADER]}), D=-13.636368 (inv) ( <b>MUST NOT</b> ), I=I( <b>RETURN_PROFIT</b> , *), C=C({PREVIOUS_ACTION=NADicoAction [A=A(*, {ROLE=[ <b>OPERATOR</b> ], ORIGIN=[MAGHRIBI], OCCUPATION=[TRADER]}), I=I( <b>TRADE</b> , *), C=C(*))}, O=(null))	

Fig. 6.1: Situational nADICO Statements for Individual Agent in Baseline Scenario

For this particular agent, the deontic range spreads from around -13.73 to +28.11, with the deontic centre lying at 0. The subranges from centre to proscriptive end, and from centre to prescriptive end are divided into equally-sized deontic compartments within the respective subranges.

Based on its experience this particular agent has inferred two nADICO statements, both of which are identified by indices. The essential features, such as actor attributes, deontic, and actions (aim) are highlighted to ease the interpretation. The statements consist of monitored statements on nesting level 0 (L0) that includes all preceding actions, as well as consequential statements, nested on Level 1 (L1), that attach an experientially derived presumed sanction for non-compliance. Translating the first statement into natural language, we can read 'Operators may want to return profit (Line 1 of Statement 1), after having been sent goods by senders (Line 3) and traded those (Line 2), or else senders must not reward operators (Line 4).' As noted before, the preceding actions leading to the monitored action are stored in the *Conditions* component of a nADICO statement on a given nesting level and may carry preceding actions on their own, as found in this example.

The second statement concerns the action 'sending goods' and reads: 'Senders must send goods (Line 1 of Statement 2), or else operators must not return profit (Line 2) after having traded those (Line 3).'

Both statements manage to capture the complexity of the interactions and role associations, while being accessible for human interpretation. However, even though both statements describe inferred obligations their deontic strength varies, with strong inclinations for sending goods (Statement 2) and initiating trade interactions themselves, while the return of profit (Statement 1) is of lesser priority. This is associated with the varying levels of reinforcement both actions experience based on the internalised feedback.

This aspect is better reflected when observing the normative understanding on the macro-level. For this purpose we rely on a Kiviat-inspired chart that shows distributions across adjacent ordinally scaled values, such as deontic terms associated with the individual deontic compartments. Figure 6.2 shows the distribution of normative understanding for identified nADICO statements, with focus on the monitored statements' *Attributes* component (in our case 'Operator' or 'Sender' and further social markers), followed by the action sequence (to be read in reverse order similar to the individual statements above, with the last action being the guarded action in the monitored statement; the consequential statement's action is omitted).

Observing the aggregated overview, we can see that the vast majority of agents (82%) feels obliged to send goods, with a minor fraction of 18% perceiving it as omissible (generally obligatory, but exceptionally foregone). Returning profit finds more moderate reinforcement, with 70% only feeling mildly inclined to do so, mostly because of the lesser feedback compared to the aggregated feedback from sending goods (which includes the incurred profit). However, in all cases the normative understanding suggests economic cooperation. This example highlights the relationship between reinforcement and the salience of a given norm for our generalisation mechanism, thus offering a possible approach to model the prioritisation of conflicting or alternative norms.

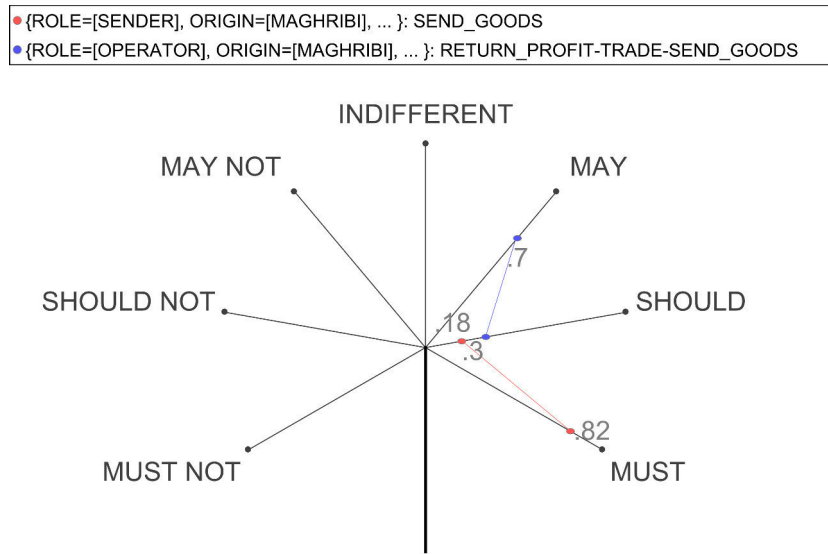

Fig. 6.2: Distribution of Normative Understanding for Baseline Scenario

With this baseline in mind, we can introduce different levels of cheating into the social composition and observe how this is reflected in the level of cooperation, as well as individuals' normative understandings.

**6.2. Modifying Behaviour: Introducing Cheating.** To analyse the effect of cheating on the artificial society, we incrementally increase  $p_{cheater}$ , i.e. the fraction of all agents that involve in cheating.

Introducing a fraction of 25% as cheaters, the society can still sustain nearly full cooperation (as shown in Table 6.2). This implies that the modelled society can sustain a moderate amount of cheating. However, to gain insight into what exactly facilitates this, we can inspect the normative understanding shown in Figure 6.3, which, in addition to the previous figure, includes an additional third action sequence, reflecting experience of cheating (to be read as 'returning profit after having been sent goods, traded, as well as cheated').

Observing the traces in the radar chart, we can see that the majority of agents has a stronger inclination to trade fair (the blue trace) than to cheat. This dominant commitment to honour the operator's obligation to return goods over cheating ensures the continued sending of goods (red trace), even though to a slightly lesser extent than in the baseline case (see Figure 6.2 in Subsection 6.1).

Only for higher levels of cheating we notice an incremental breakdown of market operations, with mean transactions counts for selected cheater fractions shown in Table 6.2. All statistical values are based on 30 simulation runs per configuration.

Table 6.2: Transaction Counts for Different Cheater Fractions

Cheater Fraction	Mean	Std. dev.
0	98.873	5.164
0.25	99.805	0.565
0.5	84.378	5.338
0.75	35.428	5.544
1	11.442	4.485

More interesting than the breakdown of market cooperation are the means by which we can retrace this

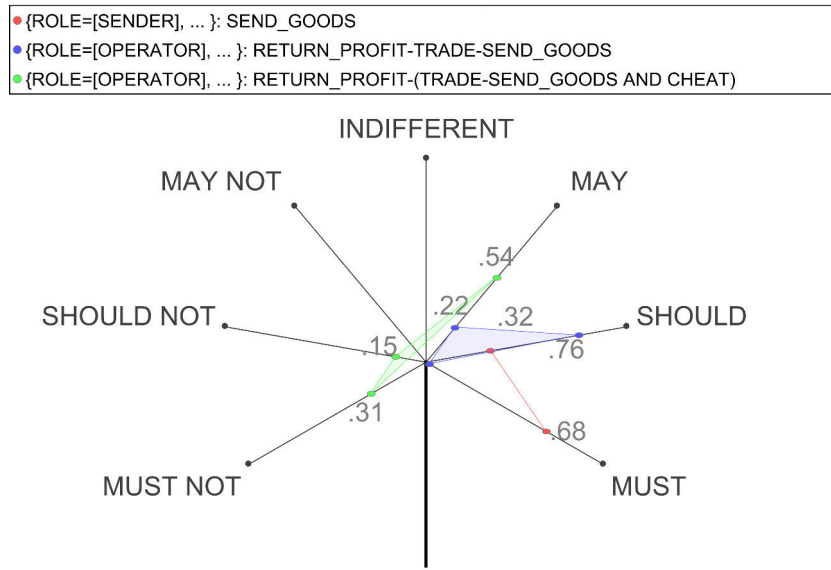

Fig. 6.3: Distribution of Normative Understanding for a Cheater Fraction of 25%

shift in normative understanding. While cheating levels up to 0.5 only affect the prioritisation of actions on the prescriptive part of the deontic range (see Figure 6.4(a)), higher levels afford a shift of the action ‘send goods’ into the proscriptive range, thus promoting the undesirability of that action (red trace) as shown for a cheater fraction of 75% in Figure 6.4(b). This shift is based on the declining revenue for initiating trades in the light of increasing levels of cheating (note the desirability of cheating (green trace) over honest trading (blue trace)) and thus the incremental breakdown of cooperation.

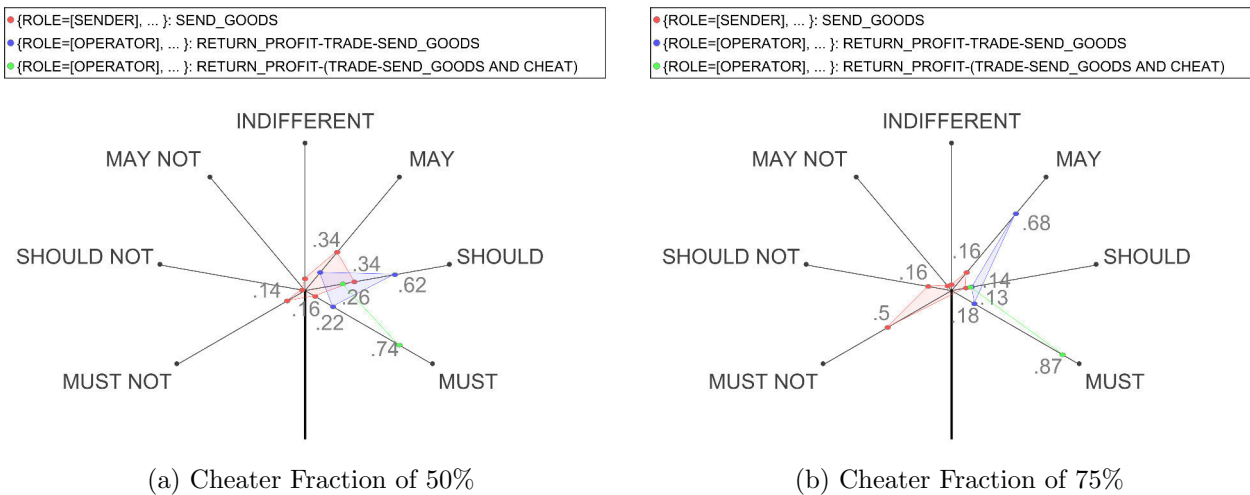

Fig. 6.4: Distribution of Normative Understanding for Different Cheater Fractions

To get a better understanding of an individual agent’s motivation to adjust its behaviour, we can observe the generated statements for an individual trader in a scenario with a cheater fraction of 75% as shown in Figure 6.5.

In this example, the agent has generated three nADICO statements, with the first one highlighting the *desirability of cheating*, the second one indicating the *undesirability of sending goods*, and the third one indi-

```

LO: A=A(*, {ROLE=[OPERATOR], ORIGIN=[MAGHRIBI], OCCUPATION=[TRADER]}), D=30.12369 (MUST), I=I(RETURN_PROFIT, *), C=C({PREVIOUS_ACTION=
  (LO: A=A(*, {ROLE=[OPERATOR], ORIGIN=[MAGHRIBI], OCCUPATION=[TRADER]}), I=I(TRADE, *), C=C({PREVIOUS_ACTION=
    LO: A=A(*, {ROLE=[SENDER], ORIGIN=[MAGHRIBI], OCCUPATION=[TRADER]}), I=I(SEND_GOODS, *), C=C(*), O=(null))), O=(null)) AND
    (LO: A=A(*, {ROLE=[OPERATOR], ORIGIN=[MAGHRIBI], OCCUPATION=[TRADER]}), I=I(CHEAT, *), C=C(*), O=(null))),
  O=(L1: A=A(*, {ROLE=[SENDER], ORIGIN=[MAGHRIBI], OCCUPATION=[TRADER]}), D=-0.4248632 (inv) (MUST NOT), I=I(FIRE, *), C=C(*), O=(null))

LO: A=A(*, {ROLE=[SENDER], ORIGIN=[MAGHRIBI], OCCUPATION=[TRADER]}), D=-0.64500105 (MUST NOT), I=I(SEND_GOODS, *), C=C(*),
O=(L1: A=A(*, {ROLE=[OPERATOR], ORIGIN=[MAGHRIBI], OCCUPATION=[TRADER]}), D=45.731926 (inv) (MUST), I=I(RETURN_PROFIT, *),
  C=C({PREVIOUS_ACTION=NADicoAction [A=A(*, {ROLE=[OPERATOR], ORIGIN=[MAGHRIBI], OCCUPATION=[TRADER]}), I=I(TRADE, *), C=C(*)]}), O=(null))

LO: A=A(*, {ROLE=[OPERATOR], ORIGIN=[MAGHRIBI], OCCUPATION=[TRADER]}), D=16.916664 (SHOULD), I=I(RETURN_PROFIT, *), C=C({PREVIOUS_ACTION=
  LO: A=A(*, {ROLE=[OPERATOR], ORIGIN=[MAGHRIBI], OCCUPATION=[TRADER]}), I=I(TRADE, *), C=C({PREVIOUS_ACTION=
    LO: A=A(*, {ROLE=[SENDER], ORIGIN=[MAGHRIBI], OCCUPATION=[TRADER]}), I=I(SEND_GOODS, *), C=C(*), O=(null))), O=(null))),
  O=(L1: A=A(*, {ROLE=[SENDER], ORIGIN=[MAGHRIBI], OCCUPATION=[TRADER]}), D=-0.23859188 (inv) (SHOULD NOT), I=I(REWARD, *), C=C(*), O=(null))

```

Fig. 6.5: Situational nADICO Statements for Individual Agent in Scenario with a Cheater Level of 75%

cating a *moderate inclination to trade fair*. We highlighted the essential *Attributes* components and actions for monitored and consequential statements. To emphasise the composite nature of the first statement (specifically in contrast to the third one), we additionally emphasised the horizontal nesting of the composite action ‘trade and cheat’ that precedes the returning of goods.

While the second and third statement bear limited novel insights, the first one clarifies the motivation as to why cheating is desirable. Interpreted literally, the agent presumes that ‘operators must trade, cheat and return the profit, or otherwise they are not fired’. This essentially reflects the inferred expectation of being fired as a result of cheating. However, even though the agent identifies this norm, it does not have any prior conception of what ‘cheating’ or ‘returning profits’ entails, but infers this based on long-term reinforcement. In this case the accumulated net pay-off of cheating and potentially being fired afterwards exceeds the pay-off received from trading fair (third statement), which makes cheating a profitable option. This interpretation shows that agents are able to identify the normative behaviour, while their actions choices remain utilitarian.

This collective shift in normative understanding with increasing penetration of cheating highlights the conditions under which cooperation can be sustained in this agent society, and beyond the quantitative evaluation of the dependent variable ‘transaction count’, gives us insight into the normative understanding on micro- and macro-level.

**6.3. Modifying Structure: Introducing Outsiders.** To explore the impact of introducing a wider set of different social actors (as opposed to merely changing behavioural composition as done up to this stage), we introduce a secondary type of trader into the social pool. While the Maghribis’ economic success built on the successful use of informal institutional instruments, European societies predominantly relied on formal institutional instruments such as contracts [19]. They did so in the light of changing social composition of their societies (especially in City States such as Genoa), lacking long-term commitment of individuals, and thus an increased incentive to cheat – since only long-term employment would have provided the necessary incentive to act compliantly.<sup>13</sup>

We thus conceive a second prototypical group of traders that is more inclined to cheat<sup>14</sup>, which we will refer to as ‘Genoese’. Note that this composition is synthetic. Historically, Maghribis and Genoese hardly engaged in trade interactions with each other [19].

With an initial fraction of 25% as Genoese (and otherwise non-cheating Maghribis), after 1000 rounds we arrive at a transaction level of around 49, i.e. effectively half of the possible transactions. The incremental breakdown for changing social compositions (in fraction levels from 0.0 to 1.0 in steps of 0.25 across 30 simulation runs each) is shown in Table 6.3.

To maintain an accessible representation of the normative understanding, we separate the aggregated statements for Maghribis and Genoese, with the Maghribi representation shown in Figure 6.6(a) and Genoese one in Figure 6.6(b).

<sup>13</sup>For an in-depth elaboration refer to [19] and [16].

<sup>14</sup>For Genoese we induce higher cheating levels by increasing the fraction of embezzled profits by 20%.



Table 6.3: Transaction Counts for Different Fractions of Genoese

Genoese Fraction	Mean	Std. dev.
0	98.873	5.164
0.25	48.997	9.48
0.5	35.52	6.966
0.75	32.003	6.634
1	8.11	3.501

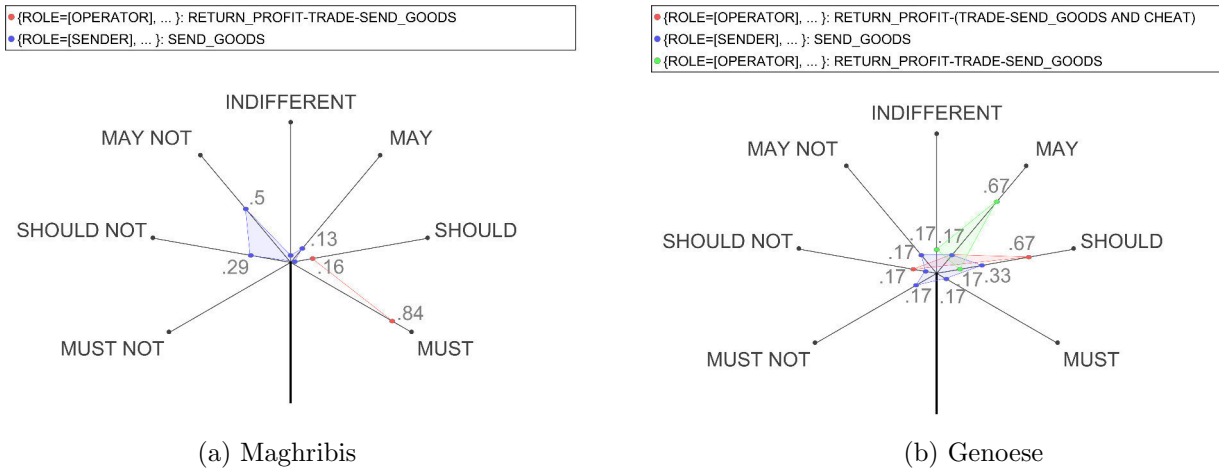

Fig. 6.6: Distribution of Normative Understanding for Maghribis and Genoese

Observing the non-cheating Maghribis, we can see how committing to trade requests and returning the generated profits is considered an obligation, since it yields in promising returns. Due to the increasing cheating levels, sending of goods becomes increasingly undesirable as of the considerable risk of being cheated by the introduced Genoese.

This complements with the impression of the Genoese traders. Genoese initiate the bulk of trade transactions, but have a clear preference for cheating, with 67% treating it as a *should*, with the same 67% of interpreting only mild inclinations for fair trading.

In essence, integrating two different trader society’s operating based on different institutional principles shows interesting interaction patterns, which we can derive from the emerging normative understanding. The Maghribis concentrate their honesty on a role as operators, i.e. pursuing Genoese’ trade dealings, while this honest trading behaviour sustains the Genoese’ commitment to inject a moderate level of goods into the market, thus preventing the economic collapse. Maintaining this base level of fair trading by Genoese senders and Maghribi operators, Genoese operators can retain their preference for cheating.

These interdependencies become clearer when inspecting individuals’ normative understandings – this time from a Genoese perspective shown in Figure 6.7.

The produced set of statements is double in size than for the uni-cultural case. Recall that Level 0 generalisation (as introduced in Subsection 4.2) operates on all social markers (nADICO’s *Attributes*), that now not only differentiates senders and operators as roles, but further includes the marker ‘origin’ (Maghribi vs. Genoese), for which normative behaviour can be characterised.

Specifically statements 2 and 3 are of particular interest. Both describe the agent’s normative understanding of cheating in the context of trading goods and returning profits, but they do so for different attribute sets. Statement 2 highlights that a Genoese operator *should* return profit to a Genoese sender when embezzling profits, whereas when dealing with a Maghribi sender, cheating is strongly undesirable. For this case, the

```

LO: A=A(*, {ROLE=[SENDER], ORIGIN=[GENOESE], OCCUPATION=[TRADER]}), D=96.73126 (MUST), I=(SEND_GOODS, *), C=C(*),
O=(L1: A=A(*, {ROLE=[OPERATOR], ORIGIN=[MAGHRIBI], OCCUPATION=[TRADER]}), D=-85.12692 (inv) (MUST NOT), I=(RETURN_PROFIT, *),
C=C({PREVIOUS_ACTION=NAdicoAction [A=A(*, {ROLE=[OPERATOR], ORIGIN=[MAGHRIBI], OCCUPATION=[TRADER]}), I=(TRADE, *), C=C(*))}), O=(null))

LO: A=A(*, {ROLE=[OPERATOR], ORIGIN=[GENOESE], OCCUPATION=[TRADER]}), D=58.2375 (SHOULD), I=(RETURN_PROFIT, *), C=C({PREVIOUS_ACTION=
(L0: A=A(*, {ROLE=[OPERATOR], ORIGIN=[GENOESE], OCCUPATION=[TRADER]}), I=(TRADE, *), C=C({PREVIOUS_ACTION=L0: A=A(*, {ROLE=[SENDER],
ORIGIN=[GENOESE], OCCUPATION=[TRADER]}), I=(SEND_GOODS, *), C=C(*), O=(null))), O=(null)) AND
(L0: A=A(*, {ROLE=[OPERATOR], ORIGIN=[GENOESE], OCCUPATION=[TRADER]}), I=(CHEAT, *), C=C(*), O=(null))),
O=(L1: A=A(*, {ROLE=[SENDER], ORIGIN=[GENOESE], OCCUPATION=[TRADER]}), D=-51.251053 (inv) (SHOULD NOT), I=(FIRE, *), C=C(*), O=(null))

LO: A=A(*, {ROLE=[OPERATOR], ORIGIN=[GENOESE], OCCUPATION=[TRADER]}), D=-72.62001 (MUST NOT), I=(RETURN_PROFIT, *), C=C({PREVIOUS_ACTION=
(L0: A=A(*, {ROLE=[OPERATOR], ORIGIN=[GENOESE], OCCUPATION=[TRADER]}), I=(TRADE, *), C=C({PREVIOUS_ACTION=L0: A=A(*, {ROLE=[SENDER],
ORIGIN=[MAGHRIBI], OCCUPATION=[TRADER]}), I=(SEND_GOODS, *), C=C(*), O=(null))), O=(null)) AND
(L0: A=A(*, {ROLE=[OPERATOR], ORIGIN=[GENOESE], OCCUPATION=[TRADER]}), I=(CHEAT, *), C=C(*), O=(null))),
O=(L1: A=A(*, {ROLE=[SENDER], ORIGIN=[MAGHRIBI], OCCUPATION=[TRADER]}), D=-82.51943 (inv) (MUST), I=(FIRE, *), C=C(*), O=(null))

LO: A=A(*, {ROLE=[SENDER], ORIGIN=[GENOESE], OCCUPATION=[TRADER]}), D=-27.59 (MAY NOT), I=(SEND_GOODS, *), C=C(*),
O=(L1: A=A(*, {ROLE=[OPERATOR], ORIGIN=[GENOESE], OCCUPATION=[TRADER]}), D=31.351017 (inv) (MAY), I=(RETURN_PROFIT, *),
C=C({PREVIOUS_ACTION=NAdicoAction [A=A(*, {ROLE=[OPERATOR], ORIGIN=[GENOESE], OCCUPATION=[TRADER]}), I=(TRADE, *), C=C(*))}), O=(null))

LO: A=A(*, {ROLE=[OPERATOR], ORIGIN=[GENOESE], OCCUPATION=[TRADER]}), D=4.9500003 (MAY), I=(RETURN_PROFIT, *), C=C({PREVIOUS_ACTION=L0: A=A(*,
{ROLE=[OPERATOR], ORIGIN=[GENOESE], OCCUPATION=[TRADER]}), I=(TRADE, *), C=C({PREVIOUS_ACTION=L0: A=A(*, {ROLE=[SENDER],
ORIGIN=[MAGHRIBI], OCCUPATION=[TRADER]}), I=(SEND_GOODS, *), C=C(*), O=(null))), O=(null))),
O=(L1: A=A(*, {ROLE=[SENDER], ORIGIN=[MAGHRIBI], OCCUPATION=[TRADER]}), D=-4.356175 (inv) (MAY NOT), I=(REWARD, *), C=C(*), O=(null))

LO: A=A(*, {ROLE=[OPERATOR], ORIGIN=[GENOESE], OCCUPATION=[TRADER]}), D=4.9500003 (MAY), I=(RETURN_PROFIT, *), C=C({PREVIOUS_ACTION=L0: A=A(*,
{ROLE=[OPERATOR], ORIGIN=[GENOESE], OCCUPATION=[TRADER]}), I=(TRADE, *), C=C({PREVIOUS_ACTION=L0: A=A(*, {ROLE=[SENDER],
ORIGIN=[GENOESE], OCCUPATION=[TRADER]}), I=(SEND_GOODS, *), C=C(*), O=(null))), O=(null))),
O=(L1: A=A(*, {ROLE=[SENDER], ORIGIN=[GENOESE], OCCUPATION=[TRADER]}), D=-4.356175 (inv) (MAY NOT), I=(REWARD, *), C=C(*), O=(null))

```

Fig. 6.7: Situational nADICO Statements for Individual Genoese Agent in Scenario with 25% Genoese

Genoese operator favours fair trading instead (Statement 5).

To understand how this differentiation comes about, we recall the principles of evaluating cheating: agents evaluate the situational profit for negative values, but also keep track of historical cheating both on individual level (i.e. past returned profits of individual agents) and global level (i.e. average across all past trade interactions), which makes the evaluation relative to the context agents interact in. For example, interacting within a pool of cheaters the embezzling of profit is less likely to be identified, in contrast to a predominantly compliant environment. As mentioned above, Maghribis stop initiating trade interactions (by sending goods) over the course of the simulation as of declining pay-offs (since cheaters eventually learn that cheating is profitable). In consequence, since they only act as operators they are hardly subject to cheating. However, if cheating occurs they operate based on past observations (from their earlier experience of fair trading), which leads to improved identification of cheating, resulting in negative feedback for the cheater. The Genoese, in contrast, continue to operate as senders in this mixed society and ‘got used’ to a moderate amount of cheating, which makes it less likely to identify and fire cheating individuals. Strategically, for Genoese it makes more sense to cheat their own kind, than embezzling profits from non-cheating Maghribis.

**6.4. Generalising Identified Behaviour.** This introduced complexity provides grounds for more differentiated social behaviour, with agents learning about actions as well as their social environment. However, as seen in the previous example, this complexity reflects all known categories of social structures, but does not give agents the ability to predict or stereotype behaviour on a more general level. Currently, agents can predict behaviour for ‘Genoese traders’ or ‘Maghribi traders’, but fail to characterise behaviour for traders more generally.

In Subsection 4.2 we proposed a conceptual solution by affording multi-level generalisation that systematically aggregates normative understanding by subsets of social marker combinations. In Figure 6.8 we can observe an extract (2 out of 6 statements) of the same individual’s understanding (as from Figure 6.7) on the highest generalisation level, in our case Level 2 – the generalisation of two attributes (out of three ones in our case: role, origin, occupation).

The traces concentrate on generalisations from a Genoese perspective, and result in the aggregation of statements based on the marker ‘Trader’ or ‘Genoese’. Generalisation based on the category ‘Genoese’ produces the

```

L0: A=A(*, {OCCUPATION=[TRADER]}), D=27.663889 (MAY), I=I(TRADE, *), C=C({PREVIOUS_ACTION=L0: A=A(*,
    {OCCUPATION=[TRADER]}), I=I(SEND_GOODS, *), C=C(*), O=(null)}),
    O=(L1: A=A(*, {OCCUPATION=[TRADER]}), D=-24.345198 (inv) (MAY NOT), I=I(RETURN_PROFIT, *), C=C(*), O=(null))

L0: A=A(*, {ORIGIN=[GENOESE]}), D=-16.859093 (MAY NOT), I=I(TRADE, *), C=C({PREVIOUS_ACTION=L0: A=A(*,
    {ORIGIN=[GENOESE]}), I=I(SEND_GOODS, *), C=C(*), O=(null)}),
    O=(L1: A=A(*, {ORIGIN=[GENOESE]}), D=19.157293 (inv) (MAY), I=I(RETURN_PROFIT, *), C=C(*), O=(null))

L0: A=A(*, {OCCUPATION=[TRADER]}), D=-14.461121 (MAY NOT), I=I(RETURN_PROFIT, *), C=C({PREVIOUS_ACTION=
    (L0: A=A(*, {OCCUPATION=[TRADER]}), I=I(TRADE, *), C=C({PREVIOUS_ACTION=L0: A=A(*,
        {OCCUPATION=[TRADER]}), I=I(SEND_GOODS, *), C=C(*), O=(null)}), O=(null)) AND
    (L0: A=A(*, {OCCUPATION=[TRADER]}), I=I(CHEAT, *), C=C(*), O=(null))}),
    O=(L1: A=A(*, {OCCUPATION=[TRADER]}), D=16.432432 (inv) (MAY), I=I(FIRE, *), C=C(*), O=(null))

L0: A=A(*, {ORIGIN=[GENOESE]}), D=58.2375 (SHOULD), I=I(RETURN_PROFIT, *), C=C({PREVIOUS_ACTION=
    (L0: A=A(*, {ORIGIN=[GENOESE]}), I=I(TRADE, *), C=C({PREVIOUS_ACTION=L0: A=A(*, {ORIGIN=[GENOESE]}),
        I=I(SEND_GOODS, *), C=C(*), O=(null)}), O=(null)) AND
    (L0: A=A(*, {ORIGIN=[GENOESE]}), I=I(CHEAT, *), C=C(*), O=(null))}),
    O=(L1: A=A(*, {ORIGIN=[GENOESE]}), D=-51.251053 (inv) (SHOULD NOT), I=I(FIRE, *), C=C(*), O=(null))

L0: A=A(*, {OCCUPATION=[TRADER]}), D=4.9500003 (MAY), I=I(RETURN_PROFIT, *), C=C({PREVIOUS_ACTION=L0: A=A(*,
    {OCCUPATION=[TRADER]}), I=I(TRADE, *), C=C({PREVIOUS_ACTION=L0: A=A(*, {OCCUPATION=[TRADER]}),
        I=I(SEND_GOODS, *), C=C(*), O=(null)}), O=(null)}),
    O=(L1: A=A(*, {OCCUPATION=[TRADER]}), D=-4.356175 (inv) (MAY NOT), I=I(REWARD, *), C=C(*), O=(null))

L0: A=A(*, {ORIGIN=[GENOESE]}), D=4.9500003 (MAY), I=I(RETURN_PROFIT, *), C=C({PREVIOUS_ACTION=L0: A=A(*,
    {ORIGIN=[GENOESE]}), I=I(TRADE, *), C=C({PREVIOUS_ACTION=L0: A=A(*, {ORIGIN=[GENOESE]}),
        I=I(SEND_GOODS, *), C=C(*), O=(null)}), O=(null)}),
    O=(L1: A=A(*, {ORIGIN=[GENOESE]}), D=-4.356175 (inv) (MAY NOT), I=I(REWARD, *), C=C(*), O=(null))

```

Fig. 6.8: Extract of Situational nADICO Statements on Generalisation Level 2 for Individual Genoese Agent in Scenario with 25% Genoese

same results as for the Level 0 generalisation (see Figure 6.7), whereas an aggregation by ‘Trader’ integrates the previously separated statements for ‘Maghribi’ and ‘Genoese’. Focusing on the cheating behaviour (Statements 1 and 2 in Figure 6.8), we find that Statement 2 corresponds to Statement 2 in Figure 6.7, while Statement 1 in Figure 6.8 is an aggregation of Statements 2 and 3 in Figure 6.7. For this example, we can now develop a more abstract picture of normative behaviour: while cheating is a desirable strategy for dealings amongst Genoese, for traders in general (which includes trades with Genoese and Maghribis) the likeliness of being fired leads to a mild disinclination (*may not*) from cheating. In principle, a Genoese trader could now ascribe this behavioural stereotype to newly entering non-Maghribi and non-Genoese traders (e.g. Venetian traders), and avoid cheating as of the anticipated negative consequence.

With this derived abstract understanding, we can reflect stereotyping capabilities that extend beyond the ‘known’ of the individual. This approach thus facilitates the *reduction of uncertainty* when dealing with newcomers, as well as providing a shortcut for decision-making, which offers the potential for an *efficiency increase* – both of which are functions characteristic for institutions [32, 50].

**7. Summary, Discussion & Outlook.** In this work we extend a comprehensive approach to model norm emergence and identification in artificial agent societies previously introduced in [15]. It builds on an expressive institutional grammar that captures different types of institutions, including conventions, norms, and rules (Subsection 3.1). The essential benefits of this structure are a) its generic and unified nature (one representation for different institution types), while b) providing what we believe is an acceptable compromise of accessible interpretation by human observers, and c) capturing institutions with great detail, facilitated by

notions of nested institutional statements.

This structural representation is augmented with a continuous conception of normative duty, capturing prohibitions, permissions, and obligations (Subsection 3.2). This not only facilitates a nuanced expression of norms and a better reflection of their evolution over time, but provides the foundation for prioritising conflicting norms along a continuous and dynamically changing deontic range. This representation is individualised, thus reflecting individuality on the micro-level, while maintaining generalisability for macro-level inspection of the normative landscape. This analysis of the normative landscape can be performed on arbitrary social aggregation levels, i.e. for all agents (macro-level), specific sub-groups (meso-level), such as cheaters or non-cheaters, as well as for an individual-centric micro-perspective.

Apart from a refinement of the aforementioned structures and their specification, the essential contribution of this work lies in the systematic formalisation of the norm identification process and its extension with a multi-level generalisation of behaviour that operates on an individual's experience of its social environment. The mechanism attempts to reconstruct subconscious norm internalisation processes by relying on concepts such as (experiential or social) learning and multi-level generalisation (stereotyping).

The integrated use of both 'structure' (nADICO & Dynamic Deontics) and 'process' (Generalisation) has been demonstrated in a multi-agent trader scenario in which agents generate experience-based normative understanding that feeds back into their action decisions. As part of the evaluation we explored the impact of cheating behaviour and structural diversity on the emerging normative understanding.

Our evaluation scenario is inspired by a realistic medieval scenario from the area of comparative economics, in which we explored the effect of cheating in societies that operate on different institutional principles, with one society being the Maghribi collective that relied on informal coordination mechanisms, and a second one, the Genoese, that inherently relied on formal coordination mechanisms to foster long-distance trade interactions. Even though the results themselves bear limited surprise with respect to the introduction of cheating – eventually economic cooperation collapses – the emerging normative understanding does. Using the proposed generalisation mechanisms we can shed light on the inner workings of individuals as well as the motivations that underlie their action selection, such as understanding why specific levels of cheating can be tolerated while sustaining economic cooperation. Another interesting finding relates to the hypothetical mixing of both societies, with Genoese goods senders developing a normative preference to interact with compliant Maghribis, while preferring to cheat their own kind when acting as operators. These conceptions cannot be validated, since no interaction between both societies has been documented [19]. However, it sheds an interesting insight into what could have happened if both collectives had interacted, and perhaps even sketching a possible reason why they did not (or ceased to do so).<sup>15</sup>

Our approach aims to provide a pragmatic account of realistic norm identification processes as evident in human beings as well as non-human species. This is in contrast to human-inspired norm engineering approaches that rely on additional assumptions, such as central coordinating entities to guarantee the identification of efficient norms (as is the case with Morales et al. [28, 29, 30]), or explicit collective action processes to facilitate consensus (as used by Riveret et al. [37]). In contrast to their work, our generalisation of social structures does not rely on prior knowledge, such as ontologies or the like, but is inferred as part of the norm identification process – the individuals themselves derive structure from behaviour. As with human societies, our conception of social norms is inherently virtual. No central entity maintains or governs a social norm. Individuals share norms via continuous internalisation and socialisation processes, but the normative understanding only exists on the micro-level. A system-wide identification of norms only occurs for evaluative purposes, a feature that is facilitated by the expressive but uniform institution representations.

The proposed process bears strong generalisability characteristics, since it operates on the subconscious level and makes minimal assumptions about agents' cognitive capabilities; it merely requires a representation of individual and social markers, as well as actions and associated feedback specifications – equivalents of which are found in most social simulation scenarios.

We further believe that this approach bears strong potential for customisation beyond scenario-specific marker and action specifications, including different configurations of the deontic range (see Subsection 3.2), or

<sup>15</sup>Recall that the Maghribis stopped sending goods in the course of the simulation because of the Genoese cheating behaviour, but continued to facilitate trading for others.

the personality- and/or culture-dependent choice of feedback aggregation strategies (see Subsection 4.3).

Similarly, the means by which agents can attain normative understanding are not constrained to reinforcement learning, but could involve notions of imitation, social learning, or even explicit communication. The latter further opens the prospect of injecting institutional (i.e. normative and/or legal) prescriptions, thus complementing the bottom-up perspective as emphasised in this work with a top-down perspective. The generalisation mechanism itself can furthermore be combined with other components to form a more realistic cognitive agent architecture, or be ‘plugged into’ existing architectures and complement explicit reasoning capabilities (such as the case with BDI-style architectures) with a subconscious norm generalisation process.

We believe that the proposed approach is an important contribution towards a more realistic representation of institutions in general, and norms in particular, moving agents an incremental step closer towards a comprehensive representation of human behaviour in silico.

#### REFERENCES

- [1] D. Acemoglu and J. Robinson. *Why Nations Fail: The Origins of Power, Prosperity, and Poverty*. Crown Business, New York (NY), 2012.
- [2] G. Andrighetto, D. Villatoro, and R. Conte. Norm Internalization in Artificial Societies. *AI Communications*, 23(4):325–339, Dec. 2010.
- [3] M. Aoki. *Toward a Comparative Institutional Analysis*. MIT Press, Cambridge (MA), 2001.
- [4] A. Bandura, D. Ross, and S. A. Ross. Transmission of Aggression through Imitation of Aggressive Models. *Journal of Abnormal and Social Psychology*, 63(3):575–582, 1961.
- [5] R. F. Baumeister, E. Bratslavsky, and C. Finkenauer. Bad is Stronger than Good. *Review of General Psychology*, 5(4):323–370, 2001.
- [6] C. Bicchieri. *The Grammar of Society: The Nature and Dynamics of Social Norms*. Cambridge University Press, New York (NY), 2006.
- [7] G. Björnsson and R. Shanklin. Must, Ought and the Structure of Standards. In F. Cariani, D. Grossi, J. Meheus, and X. Parent, editors, *Deontic Logic and Normative Systems*, volume 8554 of *Lecture Notes in Computer Science*, pages 33–48. Springer International Publishing, 2014.
- [8] S. Bradner. Key Words for Use in RFCs to Indicate Requirement Levels. <https://www.ietf.org/rfc/rfc2119.txt>, 1997. Accessed on: 1st December 2015.
- [9] C. Castelfranchi. Minds as Social Institutions. *Phenomenology and the Cognitive Sciences*, 13(1):121–143, 2014.
- [10] R. B. Cialdini, R. R. Reno, and C. A. Kallgren. A Focus Theory of Normative Conduct: Recycling the Concept of Norms to Reduce Littering in Public Places. *Journal of Personality and Social Psychology*, 58(6):1015–1026, 1990.
- [11] S. E. Crawford and E. Ostrom. A Grammar of Institutions. In *Understanding Institutional Diversity*, chapter 5, pages 137–174. Princeton University Press, Princeton (NJ), 2005.
- [12] J. Decety and J. Grèzes. The Power of Simulation: Imagining One’s Own and Other’s Behavior. *Brain Research*, 1079(1):4–14, 2006.
- [13] C. Frantz, M. K. Purvis, M. Nowostawski, and B. T. R. Savarimuthu. nADICO: A Nested Grammar of Institutions. In G. Boella, E. Elkind, B. T. R. Savarimuthu, F. Dignum, and M. K. Purvis, editors, *PRIMA 2013: Principles and Practice of Multi-Agent Systems*, volume 8291 of *Lecture Notes in Artificial Intelligence*, pages 429–436, Berlin, 2013. Springer.
- [14] C. Frantz, M. K. Purvis, M. Nowostawski, and B. T. R. Savarimuthu. Modelling Institutions using Dynamic Deontics. In T. Balke, F. Dignum, M. B. van Riemsdijk, and A. K. Chopra, editors, *Coordination, Organizations, Institutions and Norms in Agent Systems IX*, volume 8386 of *Lecture Notes in Artificial Intelligence*, pages 211–233, Berlin, 2014. Springer.
- [15] C. Frantz, M. K. Purvis, B. T. R. Savarimuthu, and M. Nowostawski. Modelling Dynamic Normative Understanding in Agent Societies. In H. K. Dam, J. Pitt, Y. Xu, G. Governatori, and T. Ito, editors, *Principles and Practice of Multi-Agent Systems - 17th International Conference, PRIMA 2014*, volume 8861 of *Lecture Notes in Artificial Intelligence*, pages 294–310, Berlin, 2014. Springer.
- [16] C. K. Frantz. *Agent-Based Institutional Modelling: Novel Techniques for Deriving Structure from Behaviour*. PhD Thesis, University of Otago, Dunedin, New Zealand, 2015. Available under: <http://hdl.handle.net/10523/5906>.
- [17] A. Ghorbani, P. Bots, V. Dignum, and G. Dijkema. MAIA: a Framework for Developing Agent-Based Social Simulations. *Journal of Artificial Societies and Social Simulation*, 16(2):9, 2013.
- [18] A. G. Greenwald and M. R. Banaji. Implicit Social Cognition: Attitudes, Self-esteem, and Stereotypes. *Psychological Review*, 102:4–27, 1995.
- [19] A. Greif. *Institutions and the Path to the Modern Economy: Lessons from Medieval Trade*. Cambridge University Press, New York (NY), 2006.
- [20] D. Grossi, H. Aldewereld, and F. Dignum. Ubi Lex, Ibi Poena: Designing Norm Enforcement in E-Institutions. In P. Noriega, J. Vázquez-Salceda, G. Boella, O. Boissier, V. Dignum, N. Fornara, and E. Matson, editors, *Coordination, Organizations, Institutions, and Norms in Multi-Agent Systems II*, volume 4386 of *Lecture Notes in Computer Science*, pages 107–120, Berlin, 2006. Springer.

- [21] S. A. Haslam, N. Ellemers, S. D. Reicher, K. J. Reynolds, and M. T. Schmitt. The Social Identity Perspective Today: An Overview of its Defining Ideas. In T. Postmes and N. R. Branscombe, editors, *Rediscovering social identity*, pages 341–356. Psychology Press, 2010.
- [22] G. M. Hodgson. The Evolution of Institutions: An Agenda for Future Theoretical Research. *Constitutional Political Economy*, 13(2):111–127, 2002.
- [23] G. Hofstede, G. J. Hofstede, and M. Minkov. *Cultures and Organizations: Software of the Mind*. McGraw-Hill, New York (NY), 3rd edition, 2010.
- [24] ISO. ISO/IEC 14977 – Information Technology - Syntactic Metalanguage - Extended BNF, December 1996. Accessed on: 1st December 2015.
- [25] S. C. Johnson. Hierarchical Clustering Schemes. *Psychometrika*, 2:241–254, 1967.
- [26] F. López y López, M. Luck, and M. d’Inverno. Normative Agent Reasoning in Dynamic Societies. In N. R. Jennings, C. Sierra, L. Sonenberg, and M. Tambe, editors, *Proceedings of the 3rd International Joint Conference on Autonomous Agents and Multi-Agent Systems*, AAMAS ’04, pages 535–542, New York (NY), 2004. ACM Press.
- [27] J. Morales, M. López-Sánchez, J. A. Rodríguez-Aguilar, W. Vasconcelos, and M. Wooldridge. Online Automated Synthesis of Compact Normative Systems. *ACM Trans. Auton. Adapt. Syst.*, 10(1):2:1–2:33, Mar. 2015.
- [28] J. Morales, M. López-Sánchez, J. A. Rodríguez-Aguilar, M. Wooldridge, and W. Vasconcelos. Automated Synthesis of Normative Systems. In *Proceedings of the 2013 International Conference on Autonomous Agents and Multi-Agent Systems*, AAMAS ’13, pages 483–490, 2013.
- [29] J. Morales, M. López-Sánchez, J. A. Rodríguez-Aguilar, M. Wooldridge, and W. Vasconcelos. Minimality and Simplicity in the On-line Automated Synthesis of Normative Systems. In *Proceedings of the 2014 International Conference on Autonomous Agents and Multi-Agent Systems*, AAMAS ’14, pages 109–116, 2014.
- [30] J. Morales, I. Mendizabal, D. Sanchez-Pinsach, M. López-Sánchez, and J. A. Rodríguez-Aguilar. Using IRON to Build Frictionless On-line Communities. *AI Commun.*, 28(1):55–71, 2015.
- [31] D. C. North. *Institutions, Institutional Change, and Economic Performance*. Cambridge University Press, New York (NY), 1990.
- [32] D. C. North. Institutions. *Journal of Economic Perspectives*, 5(1):97–112, 1991.
- [33] T. Parsons. *The Social System*. Routledge, New York (NY), 1951.
- [34] C. S. Peirce. How to Make Our Ideas Clear. *Popular Science Monthly*, 12:286–302, January 1878.
- [35] E. A. Posner. Law, Economics, and Inefficient Norms. *University of Pennsylvania Law Review*, 144:1697–1744, 1996.
- [36] R. A. Posner and E. B. Rasmusen. Creating and Enforcing Norms, with Special Reference to Sanctions. *International Review of Law and Economics*, 19(3):369–382, 1999.
- [37] R. Riveret, A. Artikis, D. Busquets, and J. Pitt. Self-governance by Transfiguration: From Learning to Prescriptions. In F. Cariani, D. Grossi, J. Meheus, and X. Parent, editors, *Deontic Logic and Normative Systems*, volume 8554 of *Lecture Notes in Computer Science*, pages 177–191. Springer, Springer, 2014.
- [38] Y. Shoham and M. Tennenholtz. On the Synthesis of Useful Social Laws for Artificial Agent Societies. In *Proceedings of the 10th National Conference on Artificial Intelligence (AAAI ’92)*, pages 276–281, San Jose (CA), July 1992.
- [39] Y. Shoham and M. Tennenholtz. On Social Laws for Artificial Agent Societies: Off-line Design. *Artificial Intelligence*, 73(12):231 – 252, 1995. Computational Research on Interaction and Agency, Part 2.
- [40] Y. Shoham and M. Tennenholtz. On the Emergence of Social Conventions: Modeling, Analysis, and Simulations. *Artificial Intelligence*, 94(1–2):139–166, July 1997.
- [41] S. Siddiki, C. M. Weible, X. Basurto, and J. Calanni. Dissecting Policy Designs: An Application of the Institutional Grammar Tool. *The Policy Studies Journal*, 39(1):79–103, 2011.
- [42] A. Smajgl, L. R. Izquierdo, and M. Huigen. Modeling Endogenous Rule Changes in an Institutional Context: The ADICO Sequence. *Advances in Complex Systems*, 2(11):199–215, 2008.
- [43] H. Tajfel. Social Identity and Intergroup Behaviour. *Social Science Information*, 13(2):65–93, 1974.
- [44] Q. van Doosselaere. *Commercial Agreements and Social Dynamics in Medieval Genoa*. Cambridge University Press, Cambridge (UK), 2009.
- [45] D. Villatoro, G. Andrighetto, J. Sabater-Mir, and R. Conte. Dynamic Sanctioning for Robust and Cost-efficient Norm Compliance. In T. Walsh, editor, *Proceedings of the 22nd International Joint Conference on Artificial Intelligence*, volume 1 of *IJCAI’11*, pages 414–419. AAAI Press, 2011.
- [46] G. H. von Wright. *An Essay in Modal Logic*. North Holland, Amsterdam, 1951.
- [47] C. Watkins. *Learning from Delayed Rewards*. PhD thesis, Cambridge University, Cambridge (UK), 1989.
- [48] O. E. Williamson. *Markets and Hierarchies, Analysis and Antitrust Implications: A Study in the Economics of Internal Organization*. Free Press, New York (NY), 1975.
- [49] O. E. Williamson. *The Economic Institutions of Capitalism*. Free Press, New York (NY), 1975.
- [50] O. E. Williamson. Transaction Cost Economics: How it works; Where it is headed. *De Economist*, 146(1):23–58, 1998.

*Edited by:* Hoa Dam

*Received:* April 16, 2015

*Accepted:* January 13, 2016



## A MULTI-AGENT APPROACH FOR TRUST-BASED SERVICE DISCOVERY AND SELECTION IN SOCIAL NETWORKS

AMINE LOUATI, JOYCE EL HADDAD, AND SUZANNE PINSON\*

**Abstract.** Service discovery and selection approaches are often done using a centralized registry-based technique, which only captures common Quality of Service criteria. With more and more services offered via *social networks*, these approaches are not able to evaluate *trust* in service providers and often fail to comply with new requester's expectations. This is because these approaches are not able (i) to take into consideration the social dimension and (ii) to capitalize on information resulting from previous experiences. To address these challenges, we propose the use of *multi-agent systems* as they have demonstrated the capability to use previous interactions, knowledge representation and distributed reasoning, as well as social metaphors like trust. More precisely, in this paper, we enhance service discovery and selection processes by integrating the societal view in trust modeling. Based on relationships between agents, their previous experiences and extracted information from social network, we define a trust model built upon *social*, *expert* and *recommender*-based components. The social-based component judges whether the provider is worthwhile pursuing before using his services (viz. trust in sociability). The expert-based component estimates whether the service behaves well and as expected (viz. trust in expertise). The recommender-based component assesses for an agent whether one's can rely on its recommendations (viz. trust in recommendation). However, when searching for a service in a social network, agents (service requester and service providers) may have no direct interactions or previous experiences. This requires a method to infer trust between them. Based on a probabilistic model, we estimate trust between non adjacent agents while taking into account roles (recommender or provider) of intermediate agents. Moreover, we propose a distributed algorithm for trustworthy service discovery and selection using referral systems in social networks. Experiments demonstrate that our approach is effective and outperforms existing ones, and can deliver more trustworthy results.

**Key words:** Service Discovery and Selection, Multi Agent System, Trust Model, Referral Systems, Social Networks.

**AMS subject classifications.** 68T42, 91D30, 90B22, 62F07

**1. Introduction.** More and more services are proposed via *social networks* (SN). In such context, a requester needs trustful and efficient methods to discover requested services given by trustees and to choose among them. Existing service discovery and selection approaches are generally based on non-functional service descriptions usually done through quality-driven techniques using QoS attributes and centralized registries (e.g. ebXML). In most of these approaches, trust is not considered ([3, 8, 11]). Recent research works ([28, 32, 38, 50]) have shown that trustworthiness is a key factor for good service selection in order to comply with requester's expectations.

This paper proposes a new approach to discover and select services based on trust. Liu and Wang in [32] defined trust as “the belief of one participant in another, based on their interactions, in the extent to which the future action to be performed by the latter will lead to an expected outcome”. Several authors have proposed to integrate the societal view into the classical service discovery process [4, 9, 28, 31]. The societal view takes into account various sources of trust information located in the social network of the trustor and considers past interaction between agents. Sabater and Vercauter distinguished in [44] three principal sources of information that agents can use to build trust: (i) individual experience between the trustor and the trustee which comes from a direct interaction between them, (ii) communicated experience which represents knowledge coming from other agents describing their interactions with the trustee and, (iii) social information which may encompass a variety of semantic and structural knowledge useful to evaluate trust (see Sect. 4 for description).

In this work, we propose to use a multi-agent system (MAS) to model the service discovery and selection process where artificial agents represent requesters, providers and intermediate agents in the social network of the requester and interactions between agents are done through message exchange. Castelfranchi and Falcone [14] claimed that trust is a basis of interactions among artificial agents in multi-agent systems: one agent must trust a counter-party to be willing to carry out interactions and delegate a task. Consequently, we design a trust model for social networks that 1) assists agents in identifying trustworthy service providers and 2) gives agents the ability to reason about trust in their distributed decision-making process. Our trust model is based on real world characteristics of trust between people that are depicted in social science studies. Other fields are

\* PSL, Université Paris-Dauphine, LAMSADE CNRS UMR 7243 Paris, France, {amine.louati,elhaddad,pinson}@lamsade.dauphine.fr

concerned with trust such as philosophy, socio-psychology and economics [2, 7, 36, 41]. All these fields show that trust could have multiple components [1, 27] and that each component can play a specific role in assessing the service trustworthiness. Some research works [29, 47, 51] focus on evaluating trust from a practical point of view by means of a reputation measure. However, this expertise-based component of trust presents several limits. As pointed out in [22, 42], trust evaluation comes from additional information sources different from those used in reputation computation such as social relationships between agents and their roles in the society. For example, [6, 32, 38, 43, 45] incorporate social network analysis as a part of the calculation of trust. Following previous works, our trust model is built upon three components namely trust in sociability, trust in expertise and trust in recommendation (see Sect. 2 for a review). First, a high sociability value indicates relevant providers and good recommenders. The interest of such a component lies in evaluating trust in a provider without relying on observations of other agents avoiding underlying subjectivity. Second, a high expertise value reflects the capability of a provider to offer good services that behaves as expected. Finally, a high recommendation value gives rise to good recommenders that one's can rely on their opinion.

During the service discovery and selection processes, agents use the aforementioned trust components to decide with whom to interact. However, in absence of direct interactions, a social and decentralized approach namely referral systems allow agents to cooperate by giving, pursuing and evaluating referrals [53]. In the literature, a number of techniques for trust inference in social networks can be found [19, 21, 33, 48, 49] but they usually focus on an evaluation based on a single trust value between adjacent agents regardless of their roles in the chain. In this paper, we propose a distributed algorithm for service discovery and selection in social networks that propagates trust values among agents using referral systems. Based on [48], we infer trust between non adjacent agents using a probabilistic model. This model takes into account roles (recommender or provider) of intermediate agents along the chain. Experiments demonstrate that our approach is better than two well-known trust methods, namely Bansal *et al.* [6], and Maaradji *et al.* [38], and can deliver more trustworthy results.

The paper is organized as follow. In the Sect. 2, we present a literature review of different trust-based approaches for service discovery and selection in social networks. Sect. 3 defines the main concepts used in this paper. Sect. 4 describes our trust model and its three components. In Sect. 5, we provide a detailed description of our trust-based discovery and selection approach. Sect. 6 discusses the experimental setup and the performance evaluation of our approach. Finally, Sect.7 concludes and presents perspectives for future work.

**2. Related Work.** In the literature, most of the existing Web service discovery and selection approaches use QoS attributes (e.g., latency, throughput, response time) to distinguish between functionally equivalent services. However, without trust consideration, selected services often fail to comply with requester's expectations. In the following, we briefly review the relevant trust-based service discovery and selection related work from three viewpoints.

**2.1. Trust-based expertise.** Many works have evaluated providers' trustworthiness from an expertise perspective [9, 25, 29, 47, 51] aiming to improve the quality of the underlying composition. Vu *et al.* [47] presented a QoS-enabled distributed service selection framework including trust and reputation management. They use some dedicated QoS registries to collect QoS feedbacks from consumers. In [51], Xu *et al.* proposed a reputation-enhanced QoS-based Web service discovery algorithm for service matching, ranking and selection based on existing Web services. Billhard *et al.* [9] examined the problem of service provider selection using an experience-based approach in which clients use confidence and reputation mechanisms to infer expectations of future providers' behavior from past experiences in similar situations. More precisely, when no previous experience is available for a particular provider/service pair, authors proposed a way to estimate confidence values based on past experiences with similar services. Lalanne *et al.* [25] proposed an approach for using quality of past experiences as a factor for service selection, including an analysis of the different factors that may affect the quality perceived by the end-user. Likewise, Li *et al.* [29] used users' feedbacks including ratings, opinions and relevant comments after use to estimate service reputation. All of the above approaches have evaluated trust from a subjective point of view based on the advertised QoS values.

**2.2. Trust-based sociability.** The expertise-based component evaluating trust between agents and services lacks social features, as for example relationships between users to make a significant assessment. To



address that, Da Silva and Zisman [17] proposed a trust model that takes into account different levels of trust among users, different relationships between users, and different degrees of importance that a user may have for certain QoS attributes. Some other works [6, 32, 38, 45] have investigated social network analysis techniques to evaluate the trust in sociability an agent may have in a provider. Bansal et al. [6] for example, evaluate providers' trustworthiness based on the degree centrality that gives an indication of their prestige in the network. However, this is a poor definition of trust, since it just uses a single measure, the degree centrality. Maraadji et al. [38], consider social proximity as an indicator to measure trust in sociability. Sierra used in [45] prestige and centrality measures to compute the strength of information flow when there is no complete independence in the opinions expressed by agents. Recently, Liu and Wang presented in [32] a service provider selection model considering both adjacent and end-to-end constraints, based on the quality of trust and a complex social network structure. This complex social network takes into consideration three concepts which are trust, social relationships and recommendation role reflecting better the real-world situations.

These works present several limits, most of them do not take into account the semantic information and deal with social networks with only one type of relationships. To cope with these limits, we integrate in the present work semantic information by including profiles and relationship types between agents in trust modeling to enhance its effectiveness and expressiveness.

**2.3. Trust-based recommendation.** The goal of a trust-based recommendation system is to generate personalized recommendations by aggregating the opinions of users in the trust network. According to Golbeck [19], recommendation techniques that analyze trust networks provide more accurate and highly personalized results than other classical collaborative filtering techniques. Golbeck proposed a FilmTrust site for generating predictive movie recommendations from trust in social network. This trust-based movie recommendation is grounded on knowledge extracted from annotations and user ratings added in the system. Hang and Singh [20] use a graph-based approach to recommend a node in a social network using similarity in trust networks. Al-Sharawneh and Williams developed in [5] an approach to model systems with autonomous interacting agents. Through a set of simulations, they investigated the impact of Goldbaum's innovative "Follow the Leader" strategy in social networks in the context of Web service selection. They use a recommender system that guides a user to select the best service that matches his requirements and preferences. Massa and Aversani [39] proposed a trust-based recommendation system where it is possible to search for trustworthy users by exploiting trust propagation over the trust network [40]. Trust-based recommendation techniques provide a way of disseminating trust information within a social network which is the basis for inferring trust between non adjacent users. However, similarly to trust-based expertise approaches, they only depend on subjective information provided by users.

**3. Preliminaries.** We describe in this section the overall concepts used in this work, i.e., social networks, services, user needs, and software agents.

**Social Networks.** We consider a Multi-Relation Social Network (MRSN) [46] which takes into account different types of relationships linking two nodes. For example, in Fig. 3.1 there are three different relationships between nodes: family, friend, and colleague relationships. Unlike multiplex networks [30] that deal with multi-layered graphs defined over the same set of nodes where each layer represents a different relationship, we assume that there is one single layer which contains different types of relationships. A multi-relation social network is modeled by a graph, where nodes represent agents and, an edge between two agents indicates a symmetric social relationship between them. More formally, a multi-relation social network and neighborhood are defined as follows:

DEFINITION 1. *Given a set  $V = \{a_1, a_2, \dots, a_n\}$  of agents and a set  $R$  of types of symmetric relationships with  $R = \{R_1, R_2, \dots, R_r\}$ , a multi-relation social network (MRSN) is a connected graph  $G = \langle V, E_1, E_2, \dots, E_r \rangle$  where  $E_i \subseteq V \times V \forall i \in \{1, \dots, r\}$  is the set of edges w.r.t the  $i$ -th relationship and  $\forall i \neq i', E_i \cap E_{i'} = \emptyset$ . Let  $\rho : E \mapsto R$  be a function that links edges to the relationship they represent, i.e. an edge  $(a_k, a_j) \in E_i$  represents a social relationship of type  $R_i$  between  $a_k$  and  $a_j$ .*

DEFINITION 2. *Given a MRSN graph  $G = (V, E)$ , the neighborhood of an agent  $a_k \in V$  w.r.t. a type of relationship  $R_i \in \{R_1, R_2, \dots, R_r\}$ , denoted  $N_{R_i}(a_k)$ , is defined as  $N_{R_i}(a_k) = \{a_j \in V \mid (a_k, a_j) \in E_i\}$ .*

In the MRSN, each agent  $a_k$  interacts with a subset of agents, called the social acquaintances  $SA_k$ . This

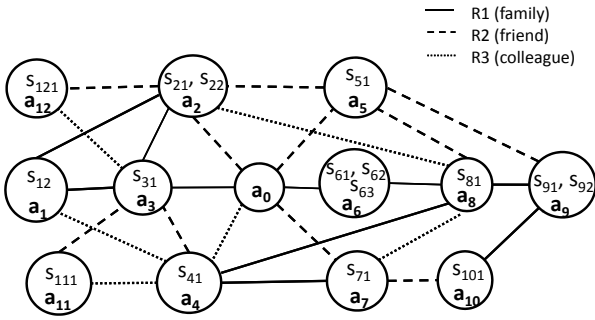

Fig. 3.1: Example of a MRSN

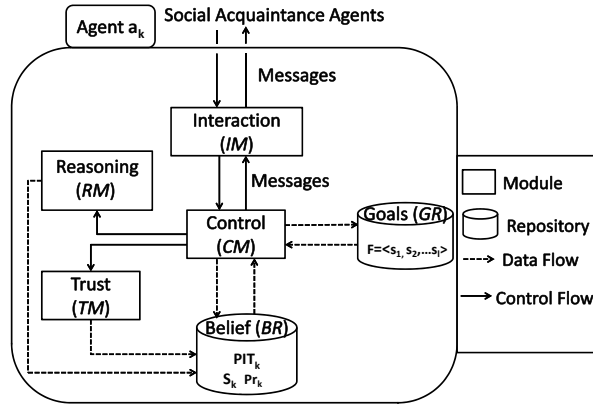

Fig. 3.2: Trust-based Agent Architecture

set represents  $a_k$ 's local view in the MRSN such as  $SA_k = \bigcup_{R_i \in R} N_{R_i}(a_k)$ .

**Services.** A service is described in terms of functionality, inputs, outputs, and non-functional attribute values. We define a service as follows:

DEFINITION 3. A service  $s$  is a  $n$ -uplet  $(in, out, f, q^1, \dots, q^d)$  where  $in$  is a set of inputs required to use the service,  $out$  is a set of outputs provided at the completion of the service,  $f$  is a functionality describing the provided capacity, and  $q^1, \dots, q^d$  are the advertised values of the  $d$  non-functional criteria.

**User needs.** A user communicates his needs by expressing a set of required services and his preferences over relationship types and trust threshold values.

DEFINITION 4. A query  $Q$  is a 5-uplet  $(F, U, \alpha, \beta, \mu)$  where  $F = \{s_1, s_2, \dots, s_l\}$  is a set of the required services,  $U : R \mapsto [0, 1]$  is an utility function expressing user's preferences over relationship types in the social network,  $\alpha \in [0, 1]$  is a trust in sociability threshold,  $\beta \in [0, 1]$  is a trust in recommendation threshold and  $\mu \in [0, 1]$  is a trust in expertise threshold.

The utility of a relationship  $R_i$ , where  $i \in \mathbb{N}^*$  is the rank of  $R_i$  in the preference order, can be defined as follows  $U(R_i) = \frac{1}{2^{i-1}}$ . For example, consider the MRSN in Fig. 3.1 with three relationship types  $R_1 = family$ ,  $R_2 = friend$  and  $R_3 = colleague$ , and a user's preferences over them such as  $family \succ friend \succ colleague$ . Therefore,  $U(R_1) = 1, U(R_2) = \frac{1}{2}$  and  $U(R_3) = \frac{1}{4}$ .

**Software Agents.** We have chosen a deliberative architecture as in [12, 18] in order to enable agents to evaluate their trust in other agents before interacting with them. It is composed of four modules and two data repositories as shown in Fig. 3.2. The four modules are: the reasoning module  $\mathcal{RM}$ , the trust module  $\mathcal{TM}$ , the control module  $\mathcal{CM}$  and the interaction module  $\mathcal{IM}$ . The two data repositories are: the belief repository  $\mathcal{BR}$  and the goal repository  $\mathcal{GR}$ .

DEFINITION 5. An agent  $a_k$  is defined as a 6-components structure  $\langle \mathcal{BR}, \mathcal{GR}, \mathcal{RM}, \mathcal{TM}, \mathcal{CM}, \mathcal{IM} \rangle$  with:

- $\mathcal{BR} = \langle Pr_k, S_k, PIT_k \rangle$ , the belief repository with  $Pr_k$  a profile<sup>1</sup>,  $S_k = \{s_{k1}, \dots, s_{km_k}\}$  a set of offered services and  $PIT_k$  a Personal Interaction Table. Each record in  $PIT_k$  (see Tab. 3.1) contains the following elements: an acquaintance agent  $a_j \in SA_k$ , the profile  $Pr_j$  of  $a_j$ , the social acquaintances set  $SA_j$  of  $a_j$  and the set of services  $S_j$  provided by  $a_j$ . This information is acquired through interactions among agents.
- $\mathcal{GR}$ , the goal repository which encompasses the required services needed to solve user's query.

<sup>1</sup>A profile consists of a set of items structured into a set of fields, each field containing one or several values (e.g., gender=[female], music-likes=[folk, jazz, pop]).

Table 3.1: Personal Interaction Table Example ( $PIT_0$  of agent  $a_0$  in Fig. 3.1)

Acquaintance	Profile	Social Acquaintances	Offered services
$a_2$	$Pr_2$	$SA_2 = \{a_0, a_1, a_3, a_5, a_8, a_{12}\}$	$S_2 = \{s_{21}, s_{22}\}$
$a_3$	$Pr_3$	$SA_3 = \{a_0, a_1, a_2, a_4, a_{11}, a_{12}\}$	$S_3 = \{s_{31}\}$
$a_4$	$Pr_4$	$SA_4 = \{a_0, a_1, a_3, a_7, a_8, a_{11}\}$	$S_4 = \{s_{41}\}$
$a_5$	$Pr_5$	$SA_5 = \{a_0, a_2, a_8, a_9\}$	$S_5 = \{s_{51}\}$
$a_6$	$Pr_6$	$SA_6 = \{a_0, a_8\}$	$S_6 = \{s_{61}, s_{62}, s_{63}\}$
$a_7$	$Pr_7$	$SA_7 = \{a_0, a_4, a_8, a_{10}\}$	$S_7 = \{s_{71}\}$

- $\mathcal{RM}$ , the reasoning module representing the matching function. A matching function between a service  $s_{kl} \in S_k$  and a service  $s \in F$  is defined as follows:  
 $matching(s, s_{kl}) = True \Leftrightarrow (s_{kl}.in \subseteq s.in) \wedge (s.out \subseteq s_{kl}.out) \wedge (s_{kl}.f \equiv s.f)$ .
- $\mathcal{TM}$ , the trust module which computes all trust measures that an agent  $a_k$  has with its social acquaintances before interacting with them.
- $\mathcal{CM}$ , the control module which manages agent's behavior and guides its decision-making in the discovery and selection process.
- $\mathcal{IM}$ , the interaction module which structures the messages built by the agent  $a_k$  and handles the received ones.

We now make some assumptions about agents and their behavior:

- *Assumption 1.* Agents are cooperative and have the good will to share their experiences with others.
- *Assumption 2.* Agents have limited view in the social network, they only know agents that belong to their social acquaintance set.
- *Assumption 3.* Agents perform decentralized decision-making in contacting other agents.

Agents are endowed with a bounded set of services and act on behalf of their associated users to discover and select trustworthy providers with good services. During the service discovery process, some agents may be good providers and some others may not be good providers but may be well connected and thus, may recommend good providers. We consider four different roles that an agent may have during the discovery process:

- *requester:* a requester is the agent that receives the query from its associated user containing the required services. It is the initiator of the discovery and selection processes. It determines from its acquaintances set the most trustworthy acquaintances and sends them the query.
- *provider:* a provider is an agent which offers one or many requested services. When an agent receives a query, it determines how to fulfill it with its offered services. If there is a matching between desired services and offered ones, it claims to be a provider and participates to the search of other potential providers by propagating the query to its trustworthy acquaintances.
- *recommender:* a recommender is an agent which has no required services but may participate to the query solving by discovering good providers. Unlike provider agent, a recommender agent queries only trustworthy acquaintances providing required services.
- *stopper:* a stopper is an agent that cannot participate to the query solving as it can neither provide a service nor recommend a provider. In the discovery process, this role is seen as a lock that blocks the query propagation in the social network. This allows us to limit the search space and reduce the computational cost.

**4. Trust Model.** This section presents our trust model for service discovery and selection processes in social networks. First, we present the different sources of information that we used for trust evaluation. Then, we describe subsequently the three trust components of our model.

**4.1. Sources of trust information.** Trust is a complex social phenomenon which is the basis of all social interactions [1]. Thus, any computational model of trust must be designed based on how trust works between people in society. As stated in [44], trust models that use only one source of information usually fail to provide a significant trust value of the trustee agent. Moreover, in a MAS context, trust evaluation is considered as an

internal reasoning from different sources of information that leads the agent to build a belief about the behavior of another agent [22]. For these reasons, we consider four different sources of information to build our trust model:

- *Individual experience*: It models the direct interaction between the trustor (i.e. agent which evaluates) and the trustee (i.e. agent which is evaluated). Based on its personal previous experiences, the trustor estimates how the trustee would behave in the current interaction. This type of information is used to compute trust in recommendation and is a part of the calculation of trust in expertise.
- *Communicated experience*: In the individual experience we considered only the direct interaction between the trustor and trustee. In the absence of direct interactions, indirect interactions or opinions of other agents can be consulted. This mechanism is called the referral system, often used for locating services through trusted referrals.
- *Social information*: In addition to agent interactional history (which are used in the two previous types of information), knowledge extracted from social networks can be a rich source for gathering information. Such information can be classified into two categories; semantic and structural. Semantic information includes trustor and trustee profiles and the relationship types between them. Structural information are derived using social network analysis techniques. It encompasses the position of the trustee in the social network graph, the proximity between the trustor and trustee and their neighborhood structure. This information is used to evaluate the trust in sociability between two agents.
- *Certified information provided by the trustee*: In the previous cases, the trustor needs to collect the required information itself. However, the trustee can also seek the trust of the trustor by presenting arguments about its trustworthiness. In this paper, such arguments are non-functional attributes (e.g., reliability, specialization, and experience rating) of the different services that it offers. In contrast to communicated experience which needs to be collected by the trustor, the trustee stores and provides such certified information on request to gain the trust of the trustor. As we mentioned before, a part of the calculation of trust in expertise is based on individual experience. The other part is based on this type of information.

Our trust model integrates these four sources of information and it is able to provide a trust evaluation that helps agents in their decision-making process when they want to interact. The problem of various sorts of disinformation and inaccuracy will be considered in future work. Integrating these various sources will also enhance the precision and the expressiveness of the trust model. This will be verified subsequently in our empirical evaluation (cf. Sect. 6).

**4.2. Trust in Sociability (ST).** Trust in sociability evaluates the level of social trust an agent  $a_k$  may have in another agent  $a_j$ . It is computed by extracting information from MRSN such as the structure of the graph, agents' profiles that contain personal data and information about their interests, and relationship types between agents. Based on the analysis of the MRSN graph and the extracted information, three measures are computed which are: *the social position* (SPo), *the social proximity* (SPr) and *the social similarity* (SSi). Next, we describe these measures, then we give the way to compute trust in sociability.

**4.2.1. Social Position Measure (SPo).** The social position of an agent  $a_j$  is computed based on its degree centrality which represents its social power. In a single-relation social network, it is computed as the degree of an agent (see for example [6]). In our work, we do not simply compute  $SPo(a_j)$  as the number of relationships of agent  $a_j$ , but we also consider relationship types  $\{R_i, 1 \leq i \leq n\}$  connecting  $a_j$  to the other agents as follows:

$$SPo(a_j) = \sum_{i=1}^r \sum_{a_l \in SA_j} U(\rho((a_j, a_l))) \times b^i(a_j, a_l) \quad (4.1)$$

where  $b^i(a_j, a_l) = 1$  iff  $a_j$  and  $a_l$  are directly connected with an edge of relationship  $R_i$ , 0 otherwise.

An agent with a high degree centrality has an important structural position in the social network because the more interactions it has, the more prestigious it is in the social network. Therefore, we believe that agents with a high degree centrality have a leading position and are considered trustworthy by other agents in the network.

**4.2.2. Social Proximity Measure (SPr).** It is defined as the average cost of a path between two agents in the graph. Since there are different kind of relationships  $\{R_i, 1 \leq i \leq n\}$  in the MRSN with preferences associated with them, we define SPr as follows:

Let  $path = (a_k, \dots, a_j)$  be a path of length  $d$  between an agent  $a_k$  and an agent  $a_j$ , and  $U(\rho((a_{l-1}, a_l)))$  be the cost of the edge  $(a_{l-1}, a_l) \in path$  (see Def. 4).

$$SPr(a_k, a_j) = \frac{\sum_{l=1}^d U(\rho((a_{l-1}, a_l)))}{d} \quad (4.2)$$

In a single-relation social network, the shortest path between a pair of agents is the best path for social proximity [38]. In a multi-relation social network and according to Eq. 4.2, proximity between two agents depends not only on the length of the path but also on semantic aspects, that is the type of links that compose it. In some cases, a longer path may have a better cost if it is composed of relationships preferred by the user.

**4.2.3. Social Similarity Measure (SSi).** The social similarity between two agents is computed based on the comparison of their profiles and their social acquaintance sets. As demonstrated in [55], we believe that similarity between two agents goes beyond the similarity of their profiles and includes similarity of their neighborhoods.  $SSi(a_k, a_j)$  is an aggregation of two measures, namely, *Neighborhood Similarity* (NS) and *Profile Similarity* (PS). First, we present NS and PS then we show how to aggregate them to compute SSi.

*Neighborhood Similarity Measure (NS).* As proved by Hang and Singh in [20], the number of common neighbors influences the trustworthy recommendation process. Thus, the higher the number of common neighbors between two agents, the higher the social intimacy degree between them. This is the case of Facebook which recommends friends based on the number of mutual friends between them. One of the fundamental principle in social psychology [41] is that an agent can trust more agents with intimate social relationships than agents with less intimacy. Following this principle, we define a measure called neighborhood similarity to find links between agents based on their social acquaintances as follows:

$$NS(a_k, a_j) = \sum_{i=1}^{|R|} U(\rho((a_{l-1}, a_l))) \times \delta^i(a_k, a_j) \quad (4.3)$$

with  $\delta^i(a_k, a_j) = \frac{1}{1+jac^i}$  where  $jac^i = \frac{y_i+z_i}{x_i+y_i+z_i}$  is the *Jaccard distance* between  $a_k$  and  $a_j$  according to the relationship  $R_i$  such as  $x_i = |N_{R_i}(a_k) \cap N_{R_i}(a_j)|$ ,  $y_i = |N_{R_i}(a_k)| - x_i$ ,  $z_i = |N_{R_i}(a_j)| - x_i$ .

*Profile Similarity (PS).* In social networks, an agent's profile is not only characterized by its acquaintances, but also by a set of personal information (e.g., gender, work) and interests (e.g., games, music, movies). We define a profile as follow:

- $\langle Profil \rangle ::= \langle item \rangle^+$
- $\langle item \rangle ::= \langle field \rangle^+$
- $\langle field \rangle ::= \langle value \rangle^*$

We use this information to compute trust between agents taking into account the similarity of their profiles. As shown in [55], in a real online community, a correlation exists between the degree of trust between agents and their profile similarity. The more two users trust each other, the more similar their profiles are. Based on these findings, we define a measure called profile similarity as follows:

$$PS(a_k, a_j) = \frac{1}{|I|} \times \sum_{i \in I} \beta_i \times S_i(a_k, a_j) \quad (4.4)$$

where  $S_i(a_k, a_j)$  is the similarity between the  $i$ th items of  $a_k$  and  $a_j$  using Burnaby measure [13],  $I$  is the set of items in profiles and  $\beta_i$  is the weight attributed to the item  $i$  with  $\sum_{i \in I} \beta_i = 1$ . For more details concerning item similarity computation, readers are referred to our previous work [34].

The overall measure of social similarity,  $SSi(a_k, a_j)$ , between a requester agent  $a_k$  and an agent  $a_j$  is computed as the product of the two above measures:

$$SSi(a_k, a_j) = NS(a_k, a_j) \times PS(a_k, a_j) \quad (4.5)$$

**4.2.4. Trust in Sociability Computation.** ST between a requester agent  $a_k$  and an agent  $a_j$  is computed from  $SPo$  (Eq. 4.1),  $SPr$  (Eq. 4.2), and  $SSi$  (Eq. 4.5). Let  $M_j$  be a vector associated with each agent  $a_j$  such as  $M_j = (SPo(a_j), SPr(a_k, a_j), SSi(a_k, a_j))$ . Let  $M$  be a matrix obtained by merging the  $M_j$  vectors of all acquaintances  $a_j$  such as  $M = (M_{jt}, a_j \in SA_k \text{ and } 1 \leq t \leq 3)$  in which each row  $M_j$  corresponds to an agent  $a_j$ , and each column corresponds to a social measure. To compute the value of the trust in sociability for each agent  $a_j$ , we use a Simple Additive Weighting technique that proceeds in two phases:

- Scaling phase: which aims to transform each measure value, of  $M_j$  vector, into a value between 0 and 1 according to the following formula.

$$M'_{jt} = \begin{cases} \frac{M_{jt} - M_t^{min}}{M_t^{max} - M_t^{min}} & \text{if } M_t^{max} - M_t^{min} \neq 0 \\ 1 & \text{if } M_t^{max} - M_t^{min} = 0 \end{cases} \quad (4.6)$$

where  $M_t^{max} = \text{Max}(M_{jt}), \forall a_j$  and  $M_t^{min} = \text{Min}(M_{jt}), \forall a_j$  are the maximal value (respectively the minimal value) of a column in the matrix  $M$ . Applying the formula 4.6 to  $M$ , we obtain a matrix  $M' = (M'_{jt}, a_j \in SA_k \text{ and } 1 \leq t \leq 3)$ , in which each row  $M'_j$  corresponds to an acquaintance  $a_j$ , and each column corresponds to a social measure.

- Weighting phase: which aims to give a social trust value to each acquaintance  $a_j \in SA_k$ . The overall social trust value is computed as follow:

$$ST(a_k, a_j) = \sum_{t=1}^3 \lambda_t \times M'_{jt}(a_k, a_j) \quad (4.7)$$

where  $\lambda_t \in [0, 1]$  is the weight of the  $t$ -th social measure with  $\sum_{t=1}^3 \lambda_t = 1$ .

**4.3. Trust in Expertise (ET).** Trust in sociability checks whether an agent is socially trustworthy or not. However, it does not evaluate the relevance of its offered services. We think that building trust solely on the basis of a social-based component is insufficient to lead to a good service selection. According to [4], when an agent relies on another socially trustworthy agent there is still an amount of risk regarding the quality of its offered services. The quality of the selection process can be improved further by assessing providers quality of service called expertise. Based on this statement, we introduce another component of trust called trust in expertise ET that considers the non-functional properties of a service. Therefore, a good agent should be not only socially trustworthy but also sufficiently expert. Based on [25], we define a trust in expertise  $ET(a_k, a_j, s_{jl})$  that an agent  $a_k$  has in a service  $s_{jl}$  offered by an agent  $a_j$  as the aggregation of three following non-functional attributes.

1. *Specialization (Sp)*: is the percentage of successful use of an agent's service  $s_{jl}$  compared to the other services it offers. It is defined as the ratio between the number of times that a service  $s_{jl}$  has been successfully completed [38] and the total number of successful executions of the agent  $a_j$  regardless of the used service.

$$Sp(s_{jl}) = \frac{Nb_{success}(s_{jl})}{\sum_{t=1}^{m_j} Nb_{success}(s_{jt})} \quad (4.8)$$

where  $Nb_{success}(s_{jl})$  is the number of successful executions of  $s_{jl}$  and  $m_j$  is the number of services offered by agent  $a_j$ . This means that the more the service  $s_{jl}$  is sought for in the social network the more  $a_j$  is recognized as an expert in this field.

2. *Reliability (Re)*: is the probability that a service  $s_{jl}$  is operational at the time of invocation. It is computed as the rate between the number of successful executions  $Nb_{success}(s_{jl})$  and the total number of functionality invocations  $Nb_{invoc}(s_{jl})$ .

$$Re(s_{jl}) = \frac{Nb_{success}(s_{jl})}{Nb_{invoc}(s_{jl})} \quad (4.9)$$

3. *Experience rating (Eval)*: is the rating of the service realization quality. After the execution of a service  $s_{jl}$ , an agent  $a_k$  gives an evaluation  $\nu \in [0, 1]$  of this execution reflecting its experience feedback as a customer of this service.

Unlike the previous attributes, the evaluation of this attribute results from a subjective perception. Let  $Eval(a_k, s_{jl})$  be the average of the experience ratings of  $s_{jl}$  for  $n$  uses by  $a_k$ .

$$Eval(a_k, s_{jl}) = \frac{\sum_{x=1}^n \nu_x}{n} \quad (4.10)$$

For the cold start, we introduce a trust bootstrapping phase. The goal for trust bootstrapping phase is to assign an initial trust value  $Eval_{ini}$  to the new services (i.e.,  $n = 0$ ). We consider two strategies: negative and positive bootstrapping. In the first strategy,  $Eval_{ini} \in [0, 0.5[$  whereas in the second strategy  $Eval_{ini} \in [0.5, 1]$ .

The overall trust in expertise  $ET(a_k, a_j, s_{jl})$  that an agent  $a_k$  have in a service  $s_{jl}$  offered by an agent  $a_j$  is computed as follows:

$$ET(a_k, a_j, s_{jl}) = Sp(s_{jl}) \times Re(s_{jl}) \times Eval(a_k, s_{jl}) \quad (4.11)$$

**4.4. Trust in Recommendation (RT).** According to [19], two types of trust are needed to evaluate the reliability of an agent: trust in this agent and trust in its recommendations for a specific service. When an agent  $a_k$  receives a recommendation from an agent  $a_j$ , apart from the fact that it ensures that  $a_j$  is socially trustworthy, it prefers also that  $a_j$  recommendations are trustworthy [7]. We associate a trust value called trust in recommendation (RT) with a service recommendation made by an  $a_j$  to  $a_k$ . The estimation of the recommendation trustworthiness is done using previous experiences with the potential recommender during past compositions. We decompose trust in recommendation  $RT(a_k, a_j, s_{pl})$  that an agent  $a_k$  gives to another agent  $a_j$  regarding the quality of its recommendations for a service  $s_{pl}$  offered by the provider  $a_p$  into two parts: the objective part,  $[r_{kj}|s_{pl}] \in [0, 1]$ , which indicates the performance of  $a_j$  in terms of the number of good recommendations for the service  $s_{pl}$ , and the subjective part,  $[q_{kj}|s_{pl}] \in [0, 1]$ , which reflects the satisfaction of the agent  $a_k$  for recommendations given by  $a_j$  concerning the service  $s_{pl}$ . Based on a formula given in [16], we define RT as follows:

$$RT(a_k, a_j, s_{pl}) = \begin{cases} 1 & \text{if } [r_{kj}|s_{pl}] = 0 \text{ or } [q_{kj}|s_{pl}] = 0 \\ ([r_{kj}|s_{pl}] + 1)^{[q_{kj}|s_{pl}]} - 1 & \text{otherwise} \end{cases} \quad (4.12)$$

As mentioned above,  $[r_{kj}|s_{pl}]$  represents the ratio of the effective selection made by  $a_k$  among the total number of recommendations of  $a_j$  for the service  $s_{pl}$  offered by the provider  $a_p$ . Based on [37],  $[r_{kj}|s_{pl}]$  is defined as follows:

$$[r_{kj}|s_{pl}] = \begin{cases} 1 & \text{if } Nbrec_{jk|s_{pl}} = 0 \\ \frac{Nbsel_{kj|s_{pl}}}{Nbrec_{jk|s_{pl}}} & \text{otherwise} \end{cases} \quad (4.13)$$

where  $Nbrec_{jk|s_{pl}}$  and  $Nbsel_{kj|s_{pl}}$  correspond to the number of times that  $a_j$  has recommended the service  $s_{pl}$  offered by  $a_p$  to  $a_k$  and the number of times that  $a_k$  has selected  $s_{pl}$  in the underlying composition, respectively.

However,  $[q_{kj}|s_{pl}]$  indicates how much an agent  $a_k$  is satisfied with the recommendations of  $a_j$  concerning the service  $s_{pl}$  offered by the provider  $a_p$ . Given  $Eval(a_k, s_{pl})$  (Eq. 4.10), the experience rating of  $s_{pl}$  given by  $a_k$  after its execution,  $[q_{kj}|s_{pl}]$  is defined as the average of the different ratings made by  $a_k$  to  $s_{pl}$  after successful executions:

$$[q_{kj}|s_{pl}] = \begin{cases} 1 & \text{if } Nbsel_{kj|s_{pl}} = 0 \\ \frac{\sum_1^{Nbsel_{kj|s_{pl}}} Eval(a_k, s_{pl})}{Nbsel_{kj|s_{pl}}} & \text{otherwise} \end{cases} \quad (4.14)$$

**5. Trust-based Service Discovery and Selection Approach Description.** In this section, we describe the three steps that encompass our Trust-based Service Discovery and Selection approach (TSDS): service discovery, trust inference, and service selection. The service discovery step (Step 1) is an algorithm composed of three phases: trust in sociability computation as defined in Sect. 4.2, matching functionalities, and computing trust in recommendation as defined in Sect. 4.4. The output of this step as shown in Fig. 5.1 is a tree graph called Trust-Relation Social Network (TRSN) in which providers as well as recommenders are identified. Relationships between agents in TRSN are weighted by a pair of values representing trust in sociability and trust in recommendation between them. The second step, trust inference (Step 2), enables the service requester to evaluate trust it has in each of the discovered providers in the TRSN. It consists of propagating trust values from each discovered provider along the chain until the service requester. The latter retrieves the propagated trust values as an input and uses them to infer its trustworthiness to each discovered provider. The output of this step is a Requester-Centered Social Network (RCSN) in which a relationship between the requester and a provider is weighted by a trust value representing the inferred trust of the requester in the corresponding provider. The third step is the service selection one (Step 3). In this last step, the service requester ranks services of discovered providers depending on the value of their trust in expertise as defined in Sect. 4.3. Only services with trust in expertise value greater than a certain threshold will be selected.

Note that in both the discovery and the selection steps of our TSDS approach, different trust components are computed. Each trust component has a specific role in the process. Trust in sociability and trust in recommendation used in Step 1 act as a first filter leading to a set of trustworthy providers and recommenders. Trust in expertise used in Step 3 enables the selection of good services among those offered by the discovered providers. This separation allows us to avoid missed opportunities during the service discovery step. If we consider trust in expertise in Step 1, only trustworthy providers will be discovered during this step and a socially trustworthy agent that does not have a required service (i.e. a recommender) will not be discovered. However, in some cases, such a trustworthy agent may be well connected and thus, may recommend a good provider.

**5.1. Step 1: Service Discovery.** The aim of this step is to discover trustworthy providers through a distributed trust-based breadth-first search algorithm, namely Algo. 1. The inputs of this algorithm are the MRSN graph and a query  $Q = (F, U, \alpha, \beta, \mu)$ . To start the algorithm, the requester agent  $a_r$  assigns itself the requester role ( $role_r = Req$ ), sets to 0 its distance  $dist_r$ <sup>2</sup> in the provider-recommender chain<sup>3</sup>, and initializes the set  $PSet_r$ <sup>4</sup> to  $\emptyset$  (see Algo. 1 lines 2 – 4).

To start the tree construction,  $a_r$  needs to ensure that queried agents are socially trustworthy. To perform trust computation,  $a_r$  updates its Personal Interaction Table  $PIT_r$  (see Tab. 3.1) regarding current information of each of its social acquaintance  $a_j \in SA_r$  (i.e., offered services  $S_j$ , social acquaintance  $SA_j$  and profile  $Pr_j$ ). To do that,  $a_r$  sends a REQUEST message to each  $a_j \in SA_r$ , (see Algo. 1 lines 5 – 7).

The behavior of an agent  $a_k$ <sup>5</sup> is event-driven: the reception of a message triggers the execution of a particular procedure. Upon receipt of a REQUEST message, an agent  $a_k$  replies with an INFORM message containing information about its offered services  $S_k$ , its social acquaintance  $SA_k$  and its profile  $Pr_k$  (see Algo. 1 lines 29 – 31). As a result of receiving an INFORM message by an agent in  $SA_r$ , the requester increments its message counter and updates its Personal Interaction Table  $PIT_r$  (see Algo. 1 lines 32 – 35). Once all INFORM messages have been received,  $a_r$  begins trust computation phase in which it evaluates trust in sociability of each acquaintance  $a_j$  based on the social measure values described in Sect. 4.2. Agents with trust in sociability

<sup>2</sup>  $dist_k$  represents the distance of an agent  $a_k$  in the provider-recommender chain to the requester agent  $a_r$  (initially equals  $+\infty$ ).

<sup>3</sup> A provider-recommender chain corresponds to a sequence of agents starting from the requester agent and leading to a provider in which all intermediate agents are either providers or recommenders.

<sup>4</sup>  $PSet_r$  is a data structure that contains for each discovered provider its offered services as well as trust values of the intermediate agents with their respective roles in the provider-recommender chain. This information is useful to infer trust that  $a_r$  has in each discovered provider.

<sup>5</sup> The index  $k$  identifies the agent executing the code.



**Algorithm 1** Distributed Trust-based Discovery Algorithm

*Variables:*  $role_k \in \{\perp, Req, Pro, Rec, Stop\}$ ,  $dist_k \in \{0, \dots, n\}$ ,  $count_k \in \{0, \dots, |SA_k|\}$ ,  $LTA_k$  a set of trustworthy potential providers,  $LRA_k$  a set of trustworthy potential recommenders,  $\tau_k$  is an array of stacks where each stack represents a provider-recommender chains of a discovered service,  $PSet_k$  a set of stacks  $\tau_k[]$  one per discovered service,  $father_k$  the predecessor agent in the chain to the requester,  $child_k$  a list of agents representing children of  $a_k$  in the tree.

```

1: procedure PROPAGATION( $F, U, \alpha, \beta, \mu$ )
2:   if ( $role_k == Req$ ) then
3:      $dist_k \leftarrow 0$ ;
4:      $PSet_k \leftarrow \emptyset$ ;
5:     for all  $a_j \in SA_k$  do
6:       Request( $a_k, a_j, \emptyset$ ); ▷ go to line 29
7:     end for
8:     wait ( $count_k == |SA_k|$ );
9:      $count_k \leftarrow 0$ ;
10:     $LTA_k \leftarrow \{a_j \in SA_k \mid ST(a_k, a_j) \geq \alpha\}$ ;
11:  end if
12:  if ( $role_k \in \{Req, Pro\}$ ) then
13:    for all  $a_j \in LTA_k$  do
14:      if ( $\exists s \in F$  and  $s_{jl} \in PIT_k.S_j \mid matching(s, s_{jl}) == True$ ) then
15:        Propagate( $a_k, a_j, (F, U, \alpha, \beta, \mu, dist_k)$ ); ▷ go to line 36
16:      else
17:        if ( $\exists s \in F \mid RT(a_k, a_j, s) \geq f_\beta(dist_k)$ ) then
18:          Propagate( $a_k, a_j, (F, U, \alpha, \beta, \mu, dist_k)$ ); ▷ go to line 36
19:        end if
20:      end if
21:    end for
22:  end if
23:  if ( $role_k == Rec$ ) then
24:    for all  $a_j \in LRA_k$  do
25:      Propagate( $a_k, a_j, (F, U, \alpha, \beta, \mu, dist_k)$ ); ▷ go to line 36
26:    end for
27:  end if
28: end procedure
29: procedure RECEIVE_REQUEST( $a_j, a_k, \emptyset$ )
30:   Inform( $a_k, a_j, (S_k, SA_k, Pr_k)$ ); ▷ go to line 32
31: end procedure
32: procedure RECEIVE_INFORM( $a_j, a_k, (S, SA, Pr)$ )
33:    $count_k \leftarrow count_k + 1$ ;
34:    $PIT_k.set(a_j, S, SA, Pr)$ ;
35: end procedure
36: procedure RECEIVE_PROPAGATE( $a_j, a_k, (F, U, \alpha, \beta, \mu, dist)$ )
37:   if ( $dist_k > dist + 1$ ) then
38:      $dist_k \leftarrow dist + 1$ ;
39:      $father_k \leftarrow a_j$ ;
40:     Inform( $a_k, father_k, child$ ); ▷ go to line 62
41:     for all  $a_j \in SA_k$  do
42:       Request( $a_k, a_j, \emptyset$ );
43:     end for
44:     wait ( $count_k == |SA_k|$ );
45:      $count_k \leftarrow 0$ ;
46:     if ( $\exists s \in F$  and  $s_{kl} \in S_k \mid matching(s, s_{kl}) == True$ ) then
47:        $role_k \leftarrow Pro$ ;
48:        $\tau_k[k].add(a_k, s_{kl})$ ;
49:        $LTA_k \leftarrow \{a_j \in SA_k \mid ST(a_k, a_j) \geq f_\alpha(dist_k)\}$ ;
50:       PROPAGATION( $F, U, \alpha, \beta, \mu$ ); ▷ go to line 12
51:     else
52:        $LRA_k \leftarrow \{a_j \in SA_k \mid ST(a_k, a_j) \geq f_\alpha(dist_k) \text{ and } \exists s \in F \text{ and } s_{jl} \in PIT_k.S_j \mid matching(s, s_{jl}) == True\}$ ;
53:       if ( $LRA_k \neq \emptyset$ ) then
54:          $role_k \leftarrow Rec$ ;
55:         PROPAGATION( $F, U, \alpha, \beta, \mu$ ); ▷ go to line 23
56:       else
57:          $role_k \leftarrow Stop$ ;
58:       end if
59:     end if
60:   end if
61: end procedure
62: procedure RECEIVE_INFORM( $a_j, a_k, child$ )
63:    $child_k.add(a_j)$ ;
64: end procedure

```

value greater than  $\alpha$  threshold <sup>6</sup> are kept in the  $LTA_r$  set (see Algo. 1 lines 8 – 10).

An agent  $a_k$  has to check before propagating the query to a trustworthy agent  $a_j \in LTA_k$  whether it could participate or not to the query resolution. Either by offering a required service or if not, by being a potential trustworthy recommender. In both cases,  $a_k$  sends to  $a_j$  a PROPAGATE message containing the user's query and its current distance (see Algo. 1 lines 12 – 22). We use trust in recommendation threshold  $f_\beta(dist_k)$  during service discovery step to reduce the search space (i.e. visited agents) while ensuring recommendations given by trustworthy recommenders.

An agent  $a_k$  that receives a PROPAGATE message, compares the received distance value with its current distance value  $dist_k$ . If the received value is less than its current distance value then,  $a_k$  sets  $dist_k$  to the new value (see Algo. 1 lines 37 – 38). This test condition allows to give the shortest trustworthy path tree that prevents cycles. Then, it sets its father value  $father_k$  to the sender and sends to it an INFORM message containing a *child* string (see Algo. 1 lines 39 – 40). Upon receipt of an INFORM message containing a *child* string, the father adds to its  $child_k$  list the identifier of the sender (see Algo. 1 lines 62 – 64). Thanks to this INFORM, each agent knows its children in the tree. After that,  $a_k$  updates its beliefs and matches required services against its own offered services  $S_k$  using the matching function (see Algo. 1 lines 41 – 46). The matching result could lead to two cases:

- $a_k$  has a service that matches a required service. In this case,  $a_k$  sets its role to *provider* ( $role_k = Pro$ ) and initializes its stack  $\tau_k[k]$  <sup>7</sup> as follows:  $\tau_k[k] = \{a_k, s_{kl}\}$  where  $a_k$  is its identifier and  $s_{kl}$  is its offered service. Next,  $a_k$  determines the  $LTA_k$  set (see Algo. 1 lines 47 – 48). To be in this set, an acquaintance  $a_j \in SA_k$  must have a trust in sociability value  $ST(a_k, a_j)$  greater than  $f_\alpha(dist_k)$  (see Algo. 1 line 49). Thereafter,  $a_k$  executes the PROPAGATION procedure that sends a PROPAGATE message to all acquaintances in  $LTA_k$  (see Algo. 1 lines 50 and 12 – 22).
- $a_k$  does not provide any of the required services, it determines  $LRA_k$  set containing its acquaintances which are not only trustworthy but also that offer one of the required services (see Algo. 1 line 52). If  $LRA_k$  set of  $a_k$  does not contain relevant acquaintances (i.e. either they are not enough trusty to be recommended or they do not offer a required service) then, it stops the query propagation and sets its role to *stopper* ( $role_k = Stop$ ) (see Algo. 1 lines 56 – 58). Otherwise,  $a_k$  sets its role to *recommender* ( $role_k = Rec$ ) and executes the PROPAGATION procedure by sending a PROPAGATE message to all acquaintances in  $LRA_k$  (see Algo. 1 lines 53 – 55 and 23 – 27). In this case, although  $a_k$  does not provide any required service, it participates in the discovery process while leading to relevant agents.

The output of the first step is a tree called Trust-Relation Social Network (TRSN) as shown in Fig. 5.1 in which the requester is the root and the providers (black nodes) and recommenders (white nodes) are identified. The different provider-recommender chains allows to build a directed and acyclic graph where the requester is the root and the distance of each discovered provider to the requester is the length of its chain. At this stage, providers are discovered on the basis of the functional aspect as well as of the degree of their sociability. So far, the non functional aspect expressed by the trust in expertise is not yet considered.

**5.2. Step 2: Trust Inference.** In social networks, an agent evaluates the trustworthiness of another based on direct interactions with it. With the absence of direct interactions, a *trust inference mechanism* is applied. This mechanism uses trust values along paths that connect two agents to come up with a single evaluation. In this step, we first show how trust values are propagated via intermediate agents to infer trust between non adjacent agents then, we describe how to build a new tree graph called a Requester-Centered Social Network (RCSN).

<sup>6</sup>  $f_x(dist_k) = (1-x) \times (1 - e^{-\frac{dist_k}{D}}) + x$  where  $D$  is the network diameter and  $x \in \{\alpha, \beta\}$  is the function that updates trust threshold value depending on the chain length  $d$  (for more details see [35]). The initial values  $f_\alpha(0)$  and  $f_\beta(0)$  correspond respectively to  $\alpha$  and  $\beta$  the preference of the requester's query. These values are incremented locally by  $a_k$  according to its  $dist_k$ . We believe that the longer the chain is, the higher the requester's sociability and recommendation value expectations are. Therefore, it is reasonable to adjust  $\alpha$  and  $\beta$  values to the current search depth. This ensures high sociability and recommendation values for providers that are discovered far away from the requester.

<sup>7</sup>  $\tau_k$  is an array of stacks. Each stack represents a provider-recommender chain of a discovered provider containing its offered service and trust values of the intermediate agents leading to it with their respective roles.

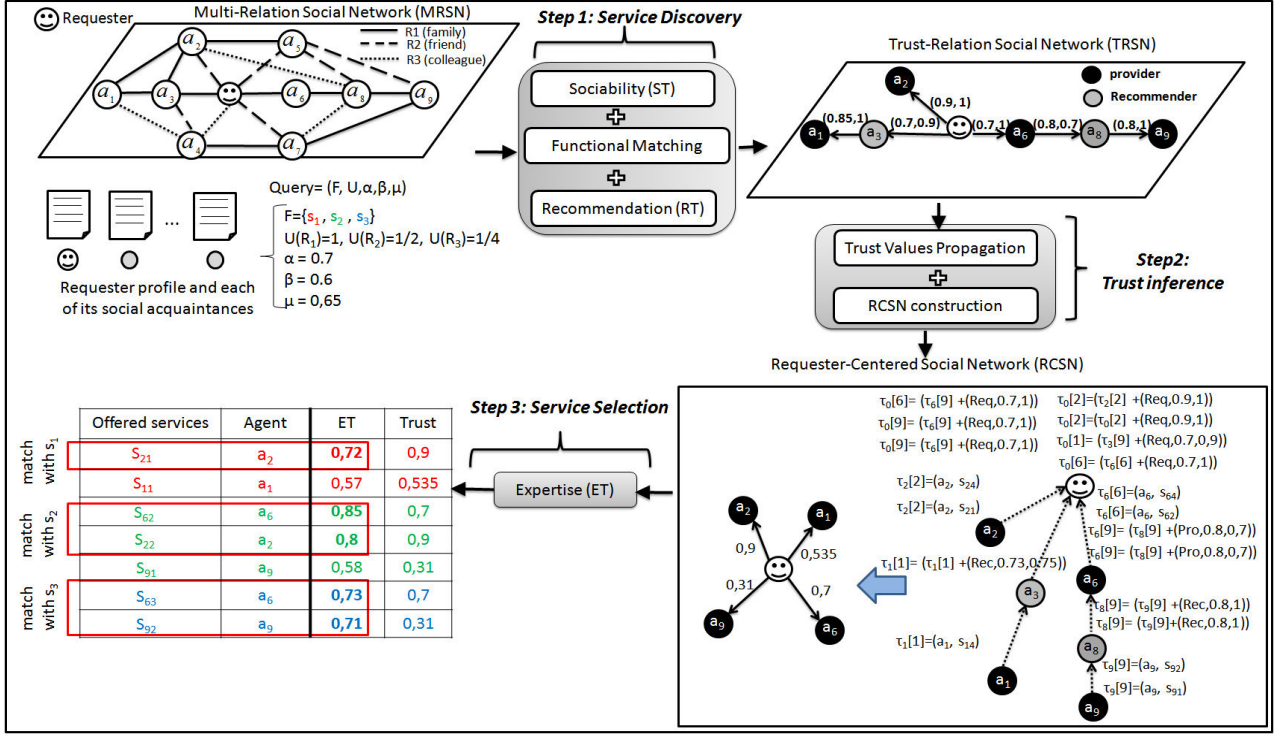

Fig. 5.1: Trust-Based Service Discovery and Selection Approach (TSDS)

**Algorithm 2** Trust Values Propagation Algorithm

```

1: procedure TRUSTINFERENCE()
2:   for all  $a_j \in \text{child}_r$  do
3:     Inform( $a_r, a_j, \text{infer}$ );
4:   end for
5: end procedure
6: procedure RECEIVE_INFORM( $a_j, a_k, \text{infer}$ )
7:   for all  $a_l \in \text{child}_k$  do
8:     Inform( $a_k, a_l, \text{infer}$ );
9:   end for
10:  if ( $\text{role}_k == \text{Pro}$ ) then
11:    Inform( $a_k, \text{father}_k, \tau_k[k]$ );
12:  end if
13: end procedure
14: procedure RECEIVE_INFORM( $a_j, a_k, \tau$ )
15:   $id \leftarrow \text{last}(\tau).get\text{Id}()$ 
16:   $\tau_k[id] \leftarrow \tau$ ;
17:  Upgrade( $\tau_k[id]$ );
18:  if ( $\text{role}_k == \text{Req}$ ) then
19:     $PSet_k \leftarrow PSet_k \cup \{\tau_k[id]\}$ ;
20:  else
21:    Inform( $a_k, \text{father}_k, \tau_k[id]$ );
22:  end if
23: end procedure

```

**Function 1** Upgrade( $\tau$ )

---

```

1: if ( $\tau.length() == 1$ ) then
2:    $role \leftarrow Pro$ ;
3: else
4:    $role \leftarrow top(\tau).getrole()$ ;
5: end if
6: if ( $role == Rec$ ) then
7:    $\tau.push(\{role_k, ST(a_k, a_j), RT(a_k, a_j)\})$ ;
8: else
9:    $\tau.push(\{role_k, ST(a_k, a_j), 1\})$ ;
10: end if

```

---

**Trust Values Propagation.** Recall that the output of the previous step is a tree where agents are either providers or recommenders and relationships between them are weighted by a pair of values representing their corresponding trust in sociability and trust in recommendation. In this second step, the requester  $a_r$  starts a trust inference algorithm, called Algo. 2, by sending to each of its children in TRSN an INFORM message containing an *infer* string (see Algo. 2 lines 1 – 5). An agent  $a_k$  that receives such a message, sends in turn each of its children an INFORM message (see Algo. 2 lines 6 – 9). Additionally, if  $a_k$  is a provider, then it sends its father in the tree an INFORM message with a copy of its  $\tau_k[k]$  containing its identifier and one of its offered services that matches one of the required services (see Algo. 2 lines 10 – 12). Upon receipt of an INFORM message containing a stack  $\tau$  from its child  $a_j$  (see Algo. 2 line 14), an agent  $a_k$  determines the *id* of the provider and applies an upgrade function (see Algo. 2 lines 15 – 17 and Func. 1) as follows. Depending on the role of  $a_j$ ,  $a_k$  inserts a new element in  $\tau_k[id]$ . If  $a_j$  is a recommender (see Func. 1 lines 6 – 7), then  $a_k$  upgrades  $\tau_k[id]$  with  $\{role_k, ST(a_k, a_j), RT(a_k, a_j)\}$  where  $role_k$  is its role,  $ST(a_k, a_j)$  and  $RT(a_k, a_j)$  are respectively its trust in sociability and trust in recommendation to its child  $a_j$ . If  $a_j$  is a provider, then  $a_k$  upgrades  $\tau_k[id]$  with  $\{role_k, ST(a_k, a_j), 1\}$ . In this case,  $a_j$  being a provider, it does not generate recommendations and therefore  $RT(a_k, a_j) = 1$  (see Func. 1 lines 8 – 10). Once the upgrading is done, if  $a_k$  is the requester agent ( $role_k == Req$ ), then it adds this stack to its  $PSet_r = PSet_r \cup \{\tau_k[id]\}$  (see Algo. 2 lines 18 – 19). Otherwise,  $a_k$  is an intermediate agent in the chain, then it applies the same mechanism by transmitting its upgraded  $\tau_k[id]$  to its father and so forth until the stack reaches the requester agent (see Algo. 2 lines 20 – 23). An example of trust values propagation in the TRSN of Fig. 5.1 from the provider  $a_9$  to the requester  $a_0$  is given in Fig. 5.2.

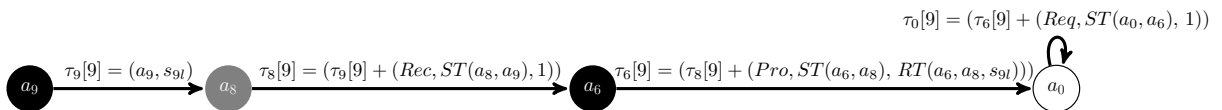

Fig. 5.2: A provider-recommender chain

At the end of Algo. 2, the requester set  $PSet_r$  contains one stack for each discovered provider  $a_p$ . Each stack includes trust values (i.e. trust in sociability and trust in recommendation) of intermediate agents in the  $chain = (a_r, a_k, a_{k+1}, \dots, a_p)$ .

Trust values propagation is essential to infer trust that the requester has in a provider although it has no direct interaction with it. In the literature, several methods have been proposed for trust inference in social networks [19, 21, 33, 49, 48]. Most of these works [21, 33, 49] propose well defined operators of aggregation to infer trust between non adjacent agents stemming from different paths. In this work, we infer trust between non adjacent agents from the provider-recommender chain based on the probabilistic approach proposed in [48]. Compared to [48], our contribution consists of integrating trust in recommendation in the calculations depending on the role of intermediate agents in the chain. Using information stored in  $PSet_r$  and the total probability law, trust of the requester  $a_r$  in a provider  $a_p$  along the chain  $(a_r, a_k, a_{k+1}, \dots, a_{p-1}, a_p)$  is inferred as follows:

$$Trust(a_r, a_p) = P(a_r) \times P(a_k|a_r) \times P(a_{k+1}|a_k) \times \dots \times P(a_p|a_{p-1}) \quad (5.1)$$

where  $P(a_r) = 1$  denotes the trustworthiness of  $a_r$  to itself.  $P(a_k|a_r)$  denotes the trustworthiness of  $a_k$  from  $a_r$ 's point of view. This is an aggregation of trust in sociability and trust in recommendation such as  $P(a_k|a_r) = ST(a_r, a_k) \times RT(a_r, a_k)$  where,  $RT(a_r, a_k) = 1$  if  $role_k = Pro$ . At the end of this phase, from  $PSet_r$  set and Eq. 5.1,  $a_r$  infers its trustworthiness in each discovered provider in the TRSN network.

**RCSN Construction.** The aim of this phase is to build a new network from the requester  $a_r$  point of view. Based on the trust value  $Trust(a_r, a_p)$  for each discovered provider  $a_p$ , we build the Requester-Centered Social Network (RCSN) modeled by a directed and weighted tree graph  $G' = (V', E')$ , where  $V'$  is the set of providers and the requester, and  $E'$  is the set of edges. An edge  $(a_r, a_p) \in E'$  is a social trust relationship between  $a_r$  and  $a_p$  and the weight of an edge  $(a_r, a_p)$  is the inferred trust value between them. Detailed results are stored in a data structure  $PSet_r^*$  computed as follows:

$$\begin{aligned} \mathcal{F}_1 : PSet_r &\rightarrow PSet_r^* \\ \tau_r[p] &\mapsto (\tau_r[p], Trust(a_r, a_p)) \end{aligned}$$

where  $\mathcal{F}_1$  is a function that takes as input each stack  $\tau_r[p]$  of a discovered provider  $a_p$  and adds it to  $Trust(a_r, a_p)$ , its inferred trust.

**5.3. Step 3: Service Selection.** In the previous steps, the service requester  $a_r$  has discovered a set of trustworthy providers in the social network. This present step consists of sorting these discovered providers and select the best to perform the service selection. After computing the trust in expertise ET,  $a_r$  constructs an ordered set  $PSel_r$  using the following function:

$$\begin{aligned} \mathcal{F}_2 : PSet_r^* &\rightarrow PSel_r \\ (\tau_r[p], Trust(a_r, a_p)) &\mapsto (\tau_r[p], Trust(a_r, a_p), ET(a_r, a_p, s_{pl})) \end{aligned}$$

where  $\mathcal{F}_2$  is a function that takes as input each record of  $PSet_r^*$  and adds it to the trust in expertise that  $a_r$  has in  $a_p$ . Then for each required service,  $a_r$  selects providers that have a trust in expertise value greater than  $\mu$  as shown in Fig. 5.1.

**6. Experimental setup and performance evaluation.** In order to empirically evaluate TSDS, our multi-agent approach for trust-based service discovery and selection, we have developed a prototype using Java 1.7 and the Jade<sup>8</sup> multi-agent platform. The MRSN graph data was stored in a GML format<sup>9</sup>. Several experiments have been performed, and all of them were run on a 3.1GHz Core(TM) i5-2400 running windows 7, with a 8Go of RAM. In the first series of experiments, we examine the performance of our service discovery step by assessing its *effectiveness* and *efficiency*. In the second series of experiments, we focus on the evaluation of the performance of our service selection step. The performance review is carried out through a comparative study versus two trust-based approaches, Bansal *et al.* [6] and Maaradji *et al.* [38], on two criteria, *utility* and *requesters' satisfaction*. The aim of this evaluation is to check whether or not our TSDS approach helps users to acquire good providers and so, allows them to gain better utility and satisfaction comparing to other approaches. Note that none of the aforementioned approaches have presented experimental results that evaluate their performance.

**6.1. Experimental setup.** The testbed environment for evaluating our approach is a social network of agents providing services (called providers) and agents using those services (called requesters). We focus on two network families: small-world and scale-free networks. Small-world networks are defined as a family of graphs

<sup>8</sup> Telecom Italia Lab. JADE 4.3 <http://jade.tilab.com/>.

<sup>9</sup> Graph Modeling Language, 1997, <http://www.fim.uni-passau.de/en/fim/faculty/chairs/theoretische-informatik/projects.html>

<sup>10</sup> <http://snap.stanford.edu/data/egonets-Facebook.html>

exhibiting three properties: weak connectivity, strong clustering, and small diameter. Scale-free networks are networks following a power-law degree distribution, a model for describing the behavior of node degrees. Most nodes in such networks have few edges, but a few nodes have much higher degree.

In the first part (Sect. 6.2), we run simulations on synthetic graphs fitting the small-world properties (the maximal path length in each of these graphs is seven hops). To do that, we generate 5 graph instances where the number of agents is equal to 1000 and the number of edges is equal to 6000. We consider 3 categories of functionalities: transportation, accommodation and entertainment. In each of them we generate 5 different services. We equip randomly each agent with three different services, one from each category. Recall that a requester's query is defined as  $(F, U, \alpha, \beta, \mu)$ . For sake of simplicity, we suppose that requesters need only one service  $F = \{s\}$ . We vary the initial  $\alpha$ 's value in  $[0, 1]$ , while  $\beta$  and  $\mu$  are both set to 0.4.

In the second part (Sect. 6.3), we conduct experiments on a real dataset which is Facebook dataset<sup>10</sup> containing 4039 agents and 88234 edges. This dataset has been proved to possess the small-world [52] and scale-free [24] characteristics of social networks. We use the dataset WSDream<sup>11</sup> of [54] which contains 5825 Web services distributed among all agents. Each agent is equipped with three different services. Similarly, for requester's query we suppose that requesters need only one service  $F = \{s\}$ . We set trust thresholds as follows:  $\alpha = 0.6$ ,  $\beta = 0.4$  and  $\mu = 0.4$ . In both datasets (real and synthetic), we consider three type of relationships  $\{R_1, R_2, R_3\}$ . The requester's preferences over relationship types are equal to  $U(R_i) = \frac{1}{2^{i-1}}$  with  $i \in \llbracket 1, 3 \rrbracket$ . For non-functional values, we consider also the dataset WSDream of [54].

**6.2. Performance evaluation of our service discovery step.** Effectiveness consists of monitoring the average quality of providers' expertise in terms of trust in expertise for different trust in sociability threshold values. Efficiency consists of examining the distribution of the trustworthy discovered providers along the provider-recommender chain. The goal of these two experiments is to determine the best trust in sociability threshold as well as the provider-recommender chain length to enhance the service discovery results.

**Effectiveness.** This experiment evaluates the effectiveness of our service discovery step based on referral systems. It allows us to estimate in advance the quality of discovered services for different ranges of trust in sociability values. As experimental methodology, we consider the three following referral policies:

- **referAll:** an agent sends the query to all agents in its social acquaintances set. This is a special case of referencing in which trust is not considered. This is similar to GNUtella's search process [23] where queries are spread by flooding i.e. each agent forwards an incoming query to all of its neighbors if it doesn't have the required file.
- **referTrust:** only agents with sociability value above a predefined trust in sociability threshold are referred. This means, the higher the trust threshold is, the smaller the number of discovered providers is. This policy corresponds to our approach.
- **referBest:** an agent refers a single agent with the best sociability value among its acquaintances. This is similar to Freenet's routing for request messages [26], where each Freenet client forwards the request to another that is the likeliest to have the required information.

Figure 6.1 illustrates the evolution of the average quality of the expertise (averaged over all graph instances) versus the variation of the  $\alpha$ 's value of different policies. We limit the length of chains to five similar to GNUtella's time-to-live value. During the simulation, each agent generates 5 queries resulting in 5000 queries all together over which we compute the average value of the trust in expertise of discovered providers. ReferAll policy corresponds to the case where  $\alpha$ 's value is set to zero. ReferBest policy is independent of  $\alpha$  and remains constant for all values. It is interesting to note that, among the three policies, the referAll policy performs the worst and its average quality is equal to 0.27. This result can be justified given that trust is not considered. Trustworthy as well as not trustworthy providers are discovered which would substantially decrease the average quality of the expertise. Furthermore, it is also interesting to note three important points about the evolution of the average quality of the expertise of referTrust policy versus the variation of  $\alpha$ 's value. First, as shown in Fig. 6.1, the best average quality of the expertise corresponds to a  $\alpha$ 's value equals to 0.6. Thanks to this finding, we can consider this value as a reference which could be recommended to the requester before launching the service discovery process. Second, when  $\alpha = 1$ , referBest and referTrust curves intersect. This is equivalent

<sup>11</sup><http://www.wsdream.net/dataset.html>

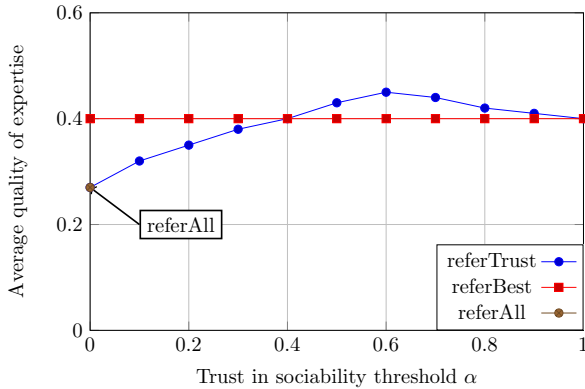

Fig. 6.1: Effectiveness of our service discovery step

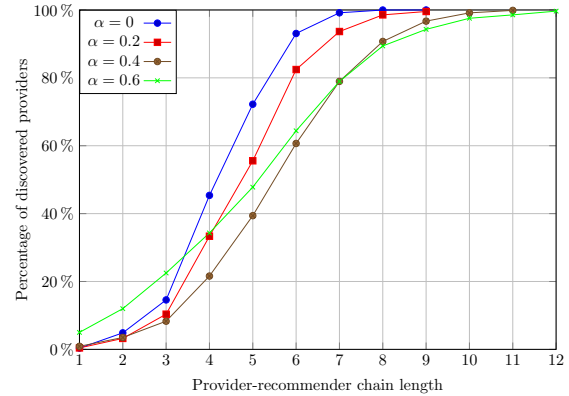

Fig. 6.2: Efficiency of our service discovery step

to keep in both policies a single agent, which is the most trustworthy one. Third, within the range of values  $[0, 0.6]$ , the referTrust policy curve has an increasing slope (i.e. providers with a low sociability also have low expertise). This indicates the existence of a correlation between the sociability and the expertise of an agent. With the increase of  $\alpha$ 's value, less trustworthy providers are found as the average value of the expertise quality increases. However, when the  $\alpha$ 's value is high, this correlation is no longer relevant. In this case, agents are too selective and few trustworthy agents are queried. This means that for high  $\alpha$ 's values, some providers with good expertise are no longer discovered because there are no chain of trustworthy agents leading to them. This indicates that these providers are socially disconnected from the requester agent.

**Efficiency.** We study in this experiment the efficiency of the discovery step according to another experimental parameter which is the length of the provider-recommender chain. During the simulation, each agent generates 5 queries resulting in 5000 queries all together over which we compute the average number of the discovered providers for different chain length.

Approaches which evaluate trust in social networks offer computational models based on social relationships which are often inferred from long paths. To illustrate this point, we represent in Fig. 6.2 the distribution in cumulative percentage of the discovered providers (averaged over all graph instances) depending on the length of the provider-recommender chain. For different  $\alpha$ 's values, we note that the number of the discovered providers in requesters' social acquaintances represents a small fraction (about 1%) of the total number of discovered providers. Some agents may not be good experts, but may be well connected and may recommend good providers hence the interest of referral systems in searching for providers. In our approach, sociability credits the ability to give good referrals. The propagation of the search is performed via navigation in the social network, which explains the increase of the number of discovered providers depending on chain length. It is also interesting to note that there is a trade-off between the length of the provider-recommender chain and the number of discovered providers. As a matter of fact, there is six times more chances (from 14% to 80%) to find a trustworthy provider in a chain length equal to 7 than in chain length equal to 3. However, the average number of discovered providers tends to level off once the chain length reaches a certain point (here equal to 8) regardless of trust threshold value. Concretely, when the chain length goes beyond a certain limit, the remaining providers are socially disconnected from the requester. Following these results, we can consider the length of the provider-recommender chain as a parameter that could be adjusted before launching the discovery process. Setting a maximum length of 7 for example gives us the possibility to control the scope of search which would substantially limit the computation cost.

**6.3. Performance evaluation of our service selection step.** In this section, we evaluate the performance and the benefit of our service selection step in terms of *utility* and *requesters' satisfaction* through a comparative study including three different approaches. The idea is to note the values of the different non-functional attributes of the selected services for each approach. Then, we compare the performance of our

three-step approach with (i) a one-step approach (i.e. Maaradji *et al.*) that aggregates trust in sociability and trust in expertise as a single value in service selection, (ii) another one-step approach (i.e. Bansal *et al.*) that uses only trust in sociability in service selection without any consideration of the non-functional aspect, and (iii) a random approach that selects services randomly and does not pay any consideration of trust. To do that, we perform experiments on real data (Facebook dataset) and we plot the averaged utility/satisfaction of selected services for all agents in the network while changing the requester agent at each round. In the experiments we test three different service selection strategies:

- Random Strategy: a requester chooses a provider randomly among potential providers. Thus, the service selection does not pay any consideration of trust.
- Basic Strategy: a requester makes its selection decision by evaluating the trustworthiness of the potential providers using Bansal *et al.* [6] or Maaradji *et al.* [38] approaches. Bansal *et al.* approach is based only on trust in sociability component using the degree centrality. Maaradji *et al.* approach considers both trust in sociability (i.e. social proximity) and trust in expertise components to evaluate the provider trustworthiness.
- Our inference Strategy: which implements TSDDS approach as described in Sect. 5. Similar to the Basic strategy, the selection decision is guided by trust. Compared to Maaradji *et al.* and Bansal *et al.* approaches, TSDDS approach intervenes at service selection step and at service discovery step.

In the social network, we define 4 sets of agents where each set of agents is equipped with a different strategy.

**Utility.** Utility is an objective criterion defined as the average of the values taken by the specialization or the reliability attributes of the selected services. In this experiment, we evaluate the utility of each strategy where each agent generates 10 queries during the simulation resulting in 40390 queries all together.

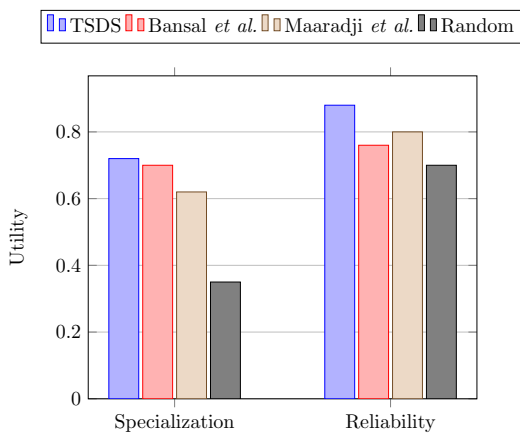

Fig. 6.3: Utility of our service selection step

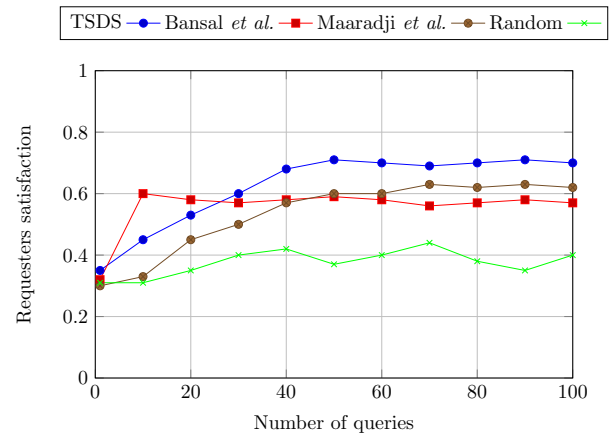

Fig. 6.4: Requesters' satisfaction of our service selection step

As we expected, Fig. 6.3 shows that Random strategy (i.e. agents that select services randomly without any consideration of trust) has the worst performance on all non-functional attributes. On the other hand, TSDDS, Bansal *et al.* and Maaradji *et al.* approaches are beneficial to requesters, helping them to obtain a significant utility i.e. services with better specialization and reliability values. This indicates that a selection strategy based on trust is more effective than without. We also note that our approach outperforms Bansal *et al.* and Maaradji *et al.* approaches on both attributes. This is because TSDDS approach is more expressive and richer as it evaluates not only sociability and expertise of an agent but also the recommendation quality of intermediate agents leading to this agent. This increases the quality of the selected services and thereafter the measured utility. The performance difference between TSDDS and Maaradji *et al.* approaches is explained by the fact that TSDDS approach differentiates between sociability and expertise when choosing an agent to interact with. This separation allows us to avoid missed opportunities at the service discovery step. A socially trustworthy agent that has low expertise will not be queried using the Maaradji *et al.* approach because the aggregation of the



two components may give a trust value below the threshold. In TSDS approach, this agent will be queried as it is socially trustworthy and even if it does not provide the required service, it can be helpful in recommending a good provider. Although Maaradji *et al.* approach is richer than Bansal *et al.* approach, since it considers both sociability (i.e. social proximity) and expertise in assessing agent's trustworthiness, we note that it is less efficient on specialization attribute. This can be explained by the fact that the specialization of a provider is naturally correlated to its degree which is the measure used by Bansal *et al.* approach. Therefore, the more an agent is specialist in a specific service, the more it is sought for in the social network. This increases the number of its interactions and subsequently its degree. These results justify the fact that the utility of Bansal *et al.* approach is better than Maaradji *et al.* approach for this attribute.

**Requesters' satisfaction.** In the second experiment, we perform the same comparative study but from a subjective point of view. Specifically, our focus will be on identifying the effect of TSDS and how it may impact requesters' satisfaction. Satisfaction is a subjective criterion that reflects the opinion of a requester regarding the behavior of a service after use. It corresponds to the average of the values taken by the attribute *Eval* for all selected services. For the initial values, we adopt a negative bootstrapping (see Sect. 4.3) to better observe the influence of the selection strategies on requesters's satisfaction. As shown in Fig. 6.4, the objective of this experiment is to examine the evolution of the requesters' satisfaction over time for each of the selection strategies: TSDS, Bansal *et al.*, Maaradji *et al.* and Random. To do that, each agent generates 100 queries (resulting in 403900 queries all together) which are sent sequentially in the social network. To monitor the progress of requesters' satisfaction, we note every 10 queries the average ratings of services after use. At the beginning of the simulation, we note that requesters' satisfaction behaves similarly for the three selection strategies. This is due to the fact that for a small number of queries, these values change slowly. However, after 10 queries we notice a significant difference in the satisfaction performance. Comparing the Bansal *et al.* approach with other groups of agents, results show that initially Bansal *et al.* approach is the most efficient. This can be explained by the fact that at the beginning of the simulation, the quality of all services is initialized with a low value (negative bootstrapping). Therefore, for a selection strategy as TSDS and Maaradji *et al.* using this attribute in trust evaluation, agents fail to find the good providers. However, these low quality values do not influence the evaluation of Bansal *et al.* approach because it is based solely on the degree centrality. Thus, providers which are selected by Bansal *et al.* with a high centrality degree have a good chance to provide good services which is the case. This confirms our intuition about the great influence of the sociability component in assessing trust. Another noticeable point is that satisfaction tends to level off after a finite number of queries and this for all selection strategies that use trust (i.e., TSDS, Bansal *et al.*, and Maaradji *et al.*). These groups of agents are able to learn gradually the quality of service, but at different speeds, the actual quality of service. For example, the TSDS agent group is the fastest group and it is able to learn after 50 queries. However, as we expected, satisfaction is fluctuating and gradually falls for a Random strategy that does not use trust. We also note that among all the selection strategies that use trust, TSDS is the most efficient because it maintains a stable and high requesters' satisfaction value. In addition, we note that after 45 queries the satisfaction in Maaradji *et al.* approach outperforms the satisfaction in Bansal *et al.* approach.

**7. Conclusion and Future Work.** In this work, we have presented an original approach for trustworthy service discovery and selection to satisfy users' needs in distributed environments like social networks. This approach is performed by a three-step process in which agents propagate the query as well as trust values in the social network using referral systems. Trustworthiness in providers and their services is evaluated over three measures namely sociability, expertise and recommendation. Sociability measure consists of analyzing the social network to evaluate the provider trustworthiness. Expertise measure quantifies the capability of the provider to offer good services. Recommendation measure evaluates the ability of an agent to give good recommendations. Based on a probabilistic approach proposed in [48], we infer trust between non adjacent agents while integrating trust in recommendation in computation. The conducted experiments have demonstrated that our model and approaches could yield more trustworthy results and recommendations than classical approaches by considering societal factors. The proposed distributed algorithms are efficient and can be applied to real social networks.

As future work, we would like to generalize, evaluate and test our approach on more complex networks such as multiplex networks. We intend also to explore the extension of our model to perform a service composition built upon a coalition formation of trust-based selected services.

## REFERENCES

- [1] A. ABDUL-RAHMAN AND S. HAILES, *Supporting trust in virtual communities*, in Proceedings of the 33rd Hawaii International Conference on System Sciences-Vol. 6, IEEE Computer Society, 2000, pp. 6007–6016.
- [2] P. ADLER, *Market, Hierarchy, and Trust: The Knowledge Economy and the Future of Capitalism*, Organization Science, 12, 2001, pp. 215–234.
- [3] E. AL-MASRI AND Q. H. MAHMOUD, *Toward quality-driven web service discovery.*, IT Professional 10, 2008, pp. 24–28.
- [4] J. AL-SHARAWNEH, *Social Networks: Service Selection and Recommendation*, PhD thesis, University of Technology, Sydney, 2012.
- [5] J. AL-SHARAWNEH AND M.-A. WILLIAMS, *Abms: Agent-based modeling and simulation in web service selection*, in Management and Service Science, 2009, pp. 1–6.
- [6] S. K. BANSAL, A. BANSAL, AND M. B. BLAKE, *Trust-based dynamic web service composition using social network analysis*, in BASNA, 2010, pp. 1–8.
- [7] E. BERSCHIED AND H. T. REIS, *Attraction and close relationships*, The handbook of social psychology, 2, 1998, pp. 193–281.
- [8] D. BIANCHINI, V. D. ANTONELLIS, AND M. MELCHIORI, *Flexible semantic-based service matchmaking and discovery.*, World Wide Web, 11, 2008, pp. 227–251.
- [9] H. BILLHARDT, R. HERMOSO, S. OSSOWSKI, AND R. CENTENO, *Trust-based service provider selection in open environments*, in Proceedings of the 2007 ACM Symposium on Applied Computing, SAC '07, ACM, 2007, pp. 1375–1380.
- [10] S. BORIAH, V. CHANDOLA, AND V. KUMAR, *Similarity measures for categorical data: A comparative evaluation*, SIAM 30, 2008, pp. 243–254.
- [11] A. BOSE, R. NAYAK, AND P. BRUZA, *Improving web service discovery by using semantic models.*, in WISE, vol. 5175, Springer, 2008, pp. 366–380.
- [12] K. BRYSON, M. LUCK, M. JOY, AND D. T. JONES, *Applying agents to bioinformatics in geneviewer*, in CIA, vol. 1860, 2000, pp. 60–71.
- [13] T. BURNABY, *On a method for character weighting a similarity coefficient, employing the concept of information*, Mathematical Geology 2, 1970, pp. 25–38.
- [14] C. CASTELFRANCHI AND R. FALCONE, *Principles of trust for mas: Cognitive anatomy, social importance, and quantification*, in Proceedings of ICMAS, IEEE Computer Society, 1998, pp. 72–79.
- [15] S. CATANESE AND P. DE MEO AND E. FERRARA AND G. FIUMARA AND A. PROVETTI, *Extraction and Analysis of Facebook Friendship Relations*, in Computational Social Networks, Springer Verlag, 2011, pp. 291–324.
- [16] M. CHEN AND J. P. SINGH, *Computing and using reputations for internet ratings.*, in ACM Conference on Electronic Commerce, ACM, 2001, pp. 154–162.
- [17] I. DA SILVA AND A. ZISMAN, *A framework for trusted services*, in Proceedings of ICSOC, Berlin, Heidelberg, 2012, pp. 328–343.
- [18] M. GEORGEFF AND A. LANSKY, *Reactive reasoning and planning.*, in Proceedings of AAAI, 1987, pp. 677–682.
- [19] J. GOLBECK, *Generating predictive movie recommendations from trust in social networks*, in Proceedings of the 4th international conference on Trust Management, Springer-Verlag, 2006, pp. 93–104.
- [20] C.-W. HANG AND M. SINGH, *Trust-based recommendation based on graph similarity*, in Proceedings of TRUST10 at AAMAS, 2010.
- [21] C.-W. HANG, Y. WANG, AND M. P. SINGH, *Operators for propagating trust and their evaluation in social networks*, in Proceedings of AAMAS, vol. 2, 2009, pp. 1025–1032.
- [22] T. D. HUYNH, N. R. JENNINGS, AND N. R. SHADBOLT, *An integrated trust and reputation model for open multi-agent systems*, Autonomous Agents and Multi-Agent Systems vol. 13, 2006, pp. 119–154.
- [23] G. KAN, 8: *GNUtella*, in Peer-to-Peer: Harnessing the Power of Disruptive Technologies, O'Reilly & Associates, Inc., Sebastopol, CA, USA, 2001, pp. 94–122.
- [24] J. KLEINBERG, *The small-world phenomenon: An algorithmic perspective*, in Proceedings of the Thirty-second Annual ACM Symposium on Theory of Computing, STOC '00, 2000, ACM, pp. 163–170.
- [25] F. LALANNE, A. CAVALLI, AND S. MAAG, *Quality of experience as a selection criterion for web services*, in SITIS, 2012, pp. 519–526.
- [26] A. LANGLET, 9: *Freenet*, in Peer-to-Peer: Harnessing the Power of Disruptive Technologies, O'Reilly & Associates, Inc., Sebastopol, CA, USA, 2001, pp. 123–132.
- [27] L. LI AND Y. WANG, *The roadmap of trust and trust evaluation in web applications and web services.*, in Advanced Web Services, A. Bouguettaya, Q. Z. Sheng, and F. Daniel, eds., Springer, 2014, pp. 75–99.
- [28] L. LI, Y. WANG, AND E.-P. LIM, *Trust-oriented composite service selection and discovery.*, in Proceedings of IC-SOC/ServiceWave, vol. 5900, 2009, pp. 50–67.
- [29] M. LI, Z. HUA, J. ZHAO, Y. ZOU, AND B. XIE, *Arima model-based web services trustworthiness evaluation and prediction.*, in Proceedings of ICSOC, Springer, 2012, pp. 648–655.
- [30] Z. LI AND Y. JIANG, *Cross-layers cascade in multiplex networks*, in Proceedings of AAMAS, 2014, pp. 269–276.
- [31] G. LIU, *Trust Management in Online Social Networks*, PhD thesis, Department of Computing Faculty of Science Macquarie University, 2013.
- [32] G. LIU AND Y. WANG, *Trust-oriented service provider selection in complex online social networks.*, in Advanced Web Services, A. Bouguettaya, Q. Z. Sheng, and F. Daniel, eds., Springer, 2014, pp. 363–380.
- [33] G. LIU, Y. WANG, AND M. A. ORGUN, *Trust transitivity in complex social networks.*, in AAAI, W. Burgard and D. Roth, eds., AAAI Press, 2011.
- [34] A. LOUATI, J. EL HADDAD, AND S. PINSON, *Trust-based service discovery in multi-relation social networks*, in Proceedings of ICSOC, 2012, pp. 664–671.

- [35] ———, *Towards agent-based and trust-oriented service discovery approach in social networks*, in TRUST14 at AAMAS, 2014, pp. 1–12.
- [36] N. LUHMANN, *Trust and Power*, John Wiley and Sons Ltd., 2012.
- [37] Z. MAAMAR, L. WIVES, B. YOUAKIM, E. SAID, B. KHOULOU, AND F. NOURA, *LinkedWS: A Novel Web Services Discovery Model Based on the Metaphor of Social Networks*, Simulation Modelling Practice and Theory, 2010, pp. 121–132.
- [38] A. MAARADJI, H. HAKIM, J. DAIGREMONT, AND N. CRESPI, *Towards a social network based approach for services composition*, IEEE International Conference on Communications, 2010, pp. 1–5.
- [39] P. MASSA AND P. AVESANI, *Trust-aware recommender systems*, in Proceedings of the ACM Conference on Recommender Systems, ACM, 2007, pp. 17–24.
- [40] B. NEVILLE, M. FASLI, AND J. PITT, *Utilising social recommendation for decision-making in distributed multi-agent systems.*, Expert Systems with Applications vol. 42, 2015, pp. 2884–2906.
- [41] M. ROWLAND, *Intimate Relationships*, McGraw-Hill College Press, 1979.
- [42] J. SABATER AND C. SIERRA, *Regret: a reputation model for gregarious societies*, in AAMAS, 2002, pp. 475–482.
- [43] ———, *Reputation and social network analysis in multi-agent systems*, in Proceedings of AAMAS, 2002, pp. 475–482.
- [44] J. SABATER AND L. VERCOUTER, *Trust and reputation in multiagent systems*, in Multiagent Systems, MIT Press, 2013, pp. 381–420.
- [45] C. SIERRA AND J. DEBENHAM, *Information-based reputation*, First International Conference on Reputation: Theory and Technology, 2009, pp. 5–19.
- [46] M. SZELL, R. LAMBIOTTE, AND S. THURNER, *Multirelational Organization of Large-scale Social Networks in an Online World*, in Proceedings of the National Academy of Science, vol. 107, 2010, pp. 13636–13641.
- [47] L.-H. VU, M. HAUSWIRTH, AND K. ABERER, *Qos-based service selection and ranking with trust and reputation management*, in OTM, Springer-Verlag, 2005, pp. 466–483.
- [48] Y. WANG, L. LI, AND G. LIU, *Social Context-Aware Trust Inference for Trust Enhancement in Social Network based Recommendations on Service Providers*, World Wide Web Journal (WWWJ), vol. 18 (1), 2015, pp. 159–184.
- [49] Y. WANG AND M. SINGH, *Trust representation and aggregation in a distributed agent system.*, in Proceedings of AAI, 2006, pp. 1425–1430.
- [50] Y. WANG AND J. VASSILEVA, *Toward Trust and Reputation Based Web Service Selection: A Survey*, ITSSA Journal, 2007.
- [51] Z. XU, P. MARTIN, W. POWLEY, AND F. H. ZULKERNINE, *Reputation-enhanced qos-based web services discovery.*, in ICWS, IEEE Computer Society, 2007, pp. 249–256.
- [52] J. WOHLGEMUTH, : *Small World Properties of Facebook Group Networks*, PhD thesis, University of Nebraska at Omaha, 2012.
- [53] B. YU AND M. SINGH, *Searching social networks*, in Proceedings of AAMAS, 2003, pp. 65–72.
- [54] Y. ZHANG, Z. ZHENG, AND M. R. LYU, *Wsexpress: A qos-aware search engine for web services*, in Proc. IEEE Int Conf. Web Services (ICWS'10), 2010, pp. 83–90.
- [55] C. ZIEGLER AND G. LAUSEN, *Analyzing correlation between trust and user similarity in online communities*, in Proceedings of Second International Conference on Trust Management, Springer-Verlag, 2004, pp. 251–265.

*Edited by:* Hoa Dam

*Received:* April 15, 2015

*Accepted:* December 31, 2015





## MULTI-OBJECTIVE DISTRIBUTED CONSTRAINT OPTIMIZATION USING SEMI-RINGS

GRAHAM BILLIAU\*, CHEE FON CHANG† AND ADITYA GHOSE‡

**Abstract.** In this paper, we extend the Support Based Distributed Optimization (SBDO) algorithm to support problems which do not have a total pre-order over the set of solutions. This is the case in common real life problems that have multiple objective functions. In particular, decision support problems. These disparate objectives are not well supported by existing Distributed Constraint Optimization Problem (DCOP) techniques, which assume a single cost or utility function. As a result, existing Distributed COP techniques (with some recent exceptions) require that all agents subscribe to a common objective function and are therefore unsuitable for settings where agents have distinct, competing objectives. This makes existing constraint optimization technologies unsuitable for many decision support roles, where the decision maker wishes to observe the different trade-offs before making a decision.

**Key words:** Multi-objective Optimisation, Constraints, Semi-Rings.

**AMS subject classifications.** 65K10, 97H40

**1. Introduction.** The simple approach of modelling DCOPs, where the cost/utility of a solution is measured as a single real number, is quite restrictive. This approach can only represent problems where there is a total pre-order over the solutions. Many real world problems only have a partial order over the solutions. Examples of these problems include problems with multiple objectives and problems with qualitative valuations. To further complicate things, a problem may include a mix of qualitative and quantitative valuations.

Bistarelli's c-semiring framework [3] is very successful for modelling problems in the Constraint Optimisation Problem (COP) domain. The Distributed Constraint Optimisation Problem (DCOP) domain introduces several new modelling challenges over centralised problems. These challenges include agent responsibility, privacy, co-operating/competing agents and no global objective. Further, these challenges lead to classes of DCOP problems which have not been addressed in the literature so far. The existing modelling frameworks do not support these new classes of problems, so we are proposing a new modelling framework inspired by c-semirings.

We have identified three classes of problems within the DCOP domain which can not be adequately described using c-semirings; equitable problems, maximisation problems and 'committee' problems. For equitable problems, we specifically refer to problems with an objective of the form 'minimise the maximum difference between the best and worst criteria'. Examples of these problems include distributing rewards to a team, assigning jobs to workers and minimise the impact of flood mitigation. Some examples of maximisation problems include maximise profit within a supply chain, maximise the value of targets tracked in a sensor network and maximise the area a team of drones can search. Committee problems are when a group of agents must agree on one (or more) shared decisions. This includes problems such as deciding on a requirements specification or a CEO's bonus package.

Equitable problems are particularly interesting within a distributed system. This is because there may not be a single 'dictator' agent who defines the entire problem. Instead the problem may grow organically, as individual agents discover they share a common goal and agree to limited co-operation. While the agents may loosely agree on the common goal, each agent has other goals, which may conflict. The end result is that there may not be a single objective which all agents subscribe to. Further, individual agents may be selfish or altruistic, which determines how much weight they put on their local objectives. In these cases, a compromise (such as an equitable solution) is required.

Equitable problems often occur in the medical setting, where the objective is to balance the patients quality of life and their survival chances. To do this, the doctor must find a balance between the most aggressive treatment (maximum survival chances, minimal quality of life) and the least aggressive treatment (minimal

\*Decision Systems Lab, University of Wollongong, NSW, Australia ([gdb339@uow.edu.au](mailto:gdb339@uow.edu.au))

†Centre for Oncology Informatics, University of Wollongong, NSW, Australia ([cfchang@uow.edu.au](mailto:cfchang@uow.edu.au))

‡Decision Systems Lab, University of Wollongong, NSW, Australia ([aditya@uow.edu.au](mailto:aditya@uow.edu.au))

survival chances, maximum quality of life). Two examples of this include treating larynx cancer and methicillin-resistant staphylococcus aureus. Radiotherapy is an effective way to treat larynx cancer, but at high doses paralyse the patient's vocal cords. Similarly, amputation is the most effective way to treat staph infections, but then the patient loses the affected limb.

One possible way to represent an equitable problem is using a tuple of  $n$  real numbers to represent the utility for each agent. This can be represented using the semiring  $\langle \mathbb{R} \times \mathbb{R} \times \dots \times \mathbb{R}, \oplus, \otimes \rangle$ . The objective is to minimise the difference between the highest and lowest values in the tuple. Defining the  $\oplus$  operator as follows captures this idea.

$$\oplus(A, B) = \begin{cases} A & \text{if } (\max(A) - \min(A)) \leq (\max(B) - \min(B)) \\ B & \text{otherwise} \end{cases}$$

where  $A = \langle a_1, a_2, \dots, a_n \rangle$  and  $B = \langle b_1, b_2, \dots, b_n \rangle$  are tuples of real numbers, so  $\max(x)$  and  $\min(x)$  return the largest or smallest value in the tuple respectively. The real numbers represent utility, so to get the total utility for an agent, the individual utilities are added together.

$$\otimes(A, B) = \langle a_1 + b_1, a_2 + b_2, \dots, a_n + b_n \rangle$$

This problem can't be represented as a c-semiring. A c-semiring requires a  $\top$  value which is the absorbing element of  $\oplus$  and the unit element of  $\otimes$ . It also requires a  $\perp$  value which is the unit element of  $\oplus$  and the absorbing element of  $\otimes$ . In this problem, there does not exist a unique 'best' value to use as  $\top$  or a unique 'worst' value to use as  $\perp$ .

Egalitarian problems, a more common class of problems with a similar intuition also can't be represented as a c-semiring. By an egalitarian problem we specifically refer to problems with the objective "maximise the minimum utility" or "minimise the maximum cost". In these problems there is still no unique best or worst value. So long as one of the values is  $\infty$ , then any assignment to the other values will compare as the equal best (or worst) value. To represent such a problem using a c-semiring, the objective must be defined as "minimise the maximum cost, then minimise the next highest cost, ... then minimise the lowest cost". This objective still satisfies "minimise the maximum cost", though it also considers the other values.

Maximisation problems are often represented using valued constraints. They can also be represented using the semiring  $\langle \mathbb{R}, \max, + \rangle$ . These problems can't be directly represented as c-semirings, as  $\infty$  is the absorbing element for both  $\max$  and  $+$ . In centralised settings, maximisation problems are commonly transformed into minimisation problems (represented by the c-semiring  $\langle \mathbb{R}_0^+, \min, +, 0, \infty \rangle$ ). This transformation involves first mapping  $\mathbb{R}$  to  $\mathbb{R}_0^-$  by subtracting  $\infty$ , then changing it to a minimisation problem by multiplying all the values by  $-1$ . Performing this transformation in practice requires knowing the maximum possible utility value. In dynamic or distributed settings, this is not possible. For dynamic settings, changes to the problem may result in a larger maximum possible utility value. For distributed settings, computing the largest possible utility value requires complete knowledge of the problem, which violates one of the assumptions of distributed problems. As the transformation is not applicable in these settings, the framework has to support the maximisation problem directly.

Finally we consider committee problems. This is a class of problems where a group of agents must agree on the answer to one (or several) decisions. Committee problems can be modelled as a standard DCOP by arbitrarily assigning agents control of decisions (variables). They could be modelled much more elegantly if agents are allowed to share control of variables. Problems of this form are usually modelled and solved as negotiation problems. If the committee problem is a sub-problem of a larger optimisation problem, then solving the larger problem requires a hybrid DCOP/negotiation algorithm or modelling the entire problem as a DCOP. Further, negotiation algorithms generally assume competitive agents, while for this work we assume cooperative, though not trusting, agents.

Committee problems are orthogonal to the utilitarian/equitable problems previously discussed. Whether a committee problem is a satisfaction, optimisation or even a multi-objective problem depends on the constraints and semiring chosen. If the agent's preferences are defined as valued constraints, then it is an optimisation problem.

We present a simple requirements engineering problem as an example of a committee problem. There are  $n$  candidate requirements (the variables,  $\mathcal{X}$ ), which have been identified during the requirement elicitation process. Each candidate requirement can either be included (True) or excluded (False) from the specification (the domains,  $D_1, \dots, D_n$ ). In addition, there are  $m$  stakeholders (the agents,  $\mathcal{A}$ ), each of whom has different preferences for which candidate requirements should be included (the constraints,  $\mathcal{C}$ ). Finally, the objective is to maximise the total utility of the stakeholders (maximisation problem,  $\mathcal{V}$ ).

In this setting all of the stakeholders know all of the candidate requirements and may propose a value for any of them. The stakeholders would like to keep their preferences private. Modelling this as a traditional DCOP problem would require arbitrarily assigning stakeholders control over the candidate constraints. Further, if we assume that each stakeholder has preferences regarding most of the constraints, then they will be forced to reveal their preferences to most of the other stakeholders. This is because most DCOP solvers require all agents involved in the constraint must know the details of the constraint. Recent work on asymmetric constraints [8] goes some way towards addressing this concern. By allowing multiple agents to share control of variables, this problem can be modelled naturally. The resulting model is also better at maintaining each agent's privacy.

These classes of problems may overlap, as shown in the following example. There are two agents  $\{1, 2\}$  sharing control of two variables  $\{X, Y\}$  with the same domain  $\{-1, 0, 1\}$ . The global objective is that the sum of the variables should be zero. Agent 1's objectives are to maximise  $X$  and minimise  $Y$ . Agent 2's objectives are to minimise  $X$  and maximise  $Y$ .

The (utilitarian) optimal solutions for this problem are:

- $X = 1, Y = -1$  (In favour of Agent 1)
- $X = -1, Y = 1$  (In favour of Agent 2)

There is one equitable solution:

- $X = 0, Y = 0$  (balance between both Agents)

A utilitarian solver will likely not return the equitable solution as a possible solution. While the equitable solution satisfies the global objective, it does not satisfy either of the local objectives.

In section 2 we describe the framework which we propose to model these classes of problems. Next we show the relationship between our framework and some of the established frameworks in section 2.3. We then detail an algorithm designed to solve problems expressed using this framework in section 3 and show the performance of the algorithm in section 4. Finally the conclusion summarises our contribution.

**2. Semiring-based Distributed Constraint Optimization Problems.** In this section, we will introduce our proposed framework, the Semiring-based Distributed Constraint Satisfaction/Optimization Problem (SDCOP). The proposed framework draws inspiration from Bistarelli et al. [3]. As such, there exists many commonalities. Bistarelli et al. [3] proposed the use of a *c-semiring* for comparing different solutions. The original formulation of a *c-semiring* was for use within the CSP domain. We view this approach to be too restrictive for use within the CSOP domain. Specifically, a *c-semiring* does not support optimization problems where the objective is to maximize utility. Objective functions of this form are required for some recent algorithms (specifically SBDO [2]). Thus, we propose the use of an idempotent semiring. The use of the semiring structure allows for two main benefits. Firstly, in multi-objective problems where no total pre-order over the solutions are prescribed, the use of an abstract structure (i.e. semirings) allows the framework to induce a partial ordering. Secondly, using an abstract comparison and aggregation operators allows the framework to support comparison and combination across both qualitative and quantitative domains.

**2.1. Preliminaries: Idempotent Semirings.** A semiring consists of a set of abstract values and two operators. The two operators allows for the comparison and combination of the prescribed abstract values.

DEFINITION 2.1. A **semiring** [17] is a tuple  $\mathcal{V} = \langle V, \oplus, \otimes \rangle$  satisfying the following conditions:

- $V$  is a set of abstract values.
- $\oplus$  is a commutative, associative and closed operator over  $V$ .
- $\otimes$  is an associative and closed operator over  $V$ .
- $\otimes$  left and right distributes over  $\oplus$ .

We shall call a semiring an **idempotent semiring** if  $\oplus$  is idempotent.

DEFINITION 2.2. [3] A *c-semiring* is a tuple  $\mathcal{V} = \langle V, \oplus, \otimes, \perp, \top \rangle$  satisfying (for all  $\alpha \in V$ ):

- $V$  is a set of abstract values with  $\perp, \top \in V$ .

- $\oplus$  is defined over possibly infinite sets as follows:
  - $\forall v \in V, \oplus(\{v\}) = v$
  - $\oplus(\emptyset) = \perp$  and  $\oplus(V) = \top$
  - $\oplus(\bigcup v_i, i \in S) = \oplus(\{\oplus(v_i), i \in S\})$  for all sets of indices  $S$
- $\otimes$  is a commutative, associative and closed binary operator on  $V$  with  $\top$  as unit element ( $\alpha \otimes \top = \alpha$ ) and  $\perp$  as absorbing element ( $\alpha \otimes \perp = \perp$ ).
- $\otimes$  distributes over  $\oplus$  (i.e.,  $\alpha \otimes (\beta \oplus \gamma) = (\alpha \otimes \beta) \oplus (\alpha \otimes \gamma)$ ).

The idempotent property of the  $\oplus$  operator can be used to obtain a partial order  $\preceq_V$  over the set of abstract values  $V$ . Such a partial order is defined as:  $\forall (v_1, v_2 \in V), v_1 \preceq_V v_2$  iff  $v_1 \oplus v_2 = v_1$  (intuitively,  $v_1 \preceq_V v_2$  denotes that  $v_1$  is at least as preferred as  $v_2$ ). The  $\oplus$  operator enables comparisons between two semiring values while the  $\otimes$  operator allows us to aggregate two semiring values.

This idempotent semiring structure is now capable of representing all the different constraint schemes. As a c-semiring is an idempotent semiring, all constraint schemes that can be represented as c-semirings can also be represented as idempotent semirings.

Bistarelli has shown that classic, fuzzy, probabilistic, weighted and set based constraints are all instances of a c-semiring [3]. Valued constraints with a maximization objective are not an instance of a c-semiring, but can be represented by the idempotent semiring  $\langle \mathfrak{R}, \max, + \rangle$  where  $\mathfrak{R}$  is the set of values,  $\max$  is the comparison operator and  $+$  is the combination operator.

Multiple idempotent semirings may be combined into a single idempotent semiring in the same way that c-semirings are combined [3]. The semirings being combined may involve evaluations on multiple heterogeneous scales - both qualitative and quantitative. We leverage this property in handling multi-objective DCOPs.

The following definition is based on that provided by Bistarelli et. al [3] (definition 7.1) for c-semiring. It formalizes the combination of idempotent semirings.

**DEFINITION 2.3.** *Given the  $n$  idempotent semirings  $S_i = \langle V_i, \oplus_i, \otimes_i, \rangle$  for  $i = 1, \dots, n$  we define the structure  $Comb(S_1, \dots, S_n) = \langle \langle V_1, \dots, V_n \rangle, \oplus, \otimes \rangle$  where  $\oplus$  and  $\otimes$  are defined as follows: Given  $\langle a_1, \dots, a_n \rangle$  and  $\langle b_1, \dots, b_n \rangle$  such that  $a_i, b_i \in V_i$  for  $i = 1, \dots, n$ ,  $\langle a_1, \dots, a_n \rangle \oplus \langle b_1, \dots, b_n \rangle = \langle a_1 \oplus_1 b_1, \dots, a_n \oplus_n b_n \rangle$  and  $\langle a_1, \dots, a_n \rangle \otimes \langle b_1, \dots, b_n \rangle = \langle a_1 \otimes_1 b_1, \dots, a_n \otimes_n b_n \rangle$ .*

**THEOREM 2.4.** *If  $S_i = \langle V_i, \oplus_i, \otimes_i \rangle$  for  $i = 1, \dots, n$  are all idempotent semirings, then  $Comb(S_1, \dots, S_n)$  is an idempotent semiring.*

*Proof.* From definition 2.3, the combined semiring uses the  $\oplus$  and  $\otimes$  operators from the component semirings directly. Hence, the properties that hold for the component semirings also hold for the combined semiring.  $\square$

If  $a \oplus b = a$  then for all components  $i$ ,  $a_i \oplus_i b_i = a_i$ . This corresponds to the ‘dominates’ concept in pareto-optimality. Hence the  $Comb()$  operator implements the commonly accepted pareto-optimal ordering over multiple objectives. If a different ordering is desired then the  $\oplus$  operator can be redefined to implement the desired ordering.

**2.2. Distributed Constraint Optimization Problems.** In Constraint Satisfaction Problems (CSPs), the constraints within the problem and the criteria that the solution must satisfy can be viewed as one and the same. However Constraint Satisfaction/Optimisation Problems (CSOPs) allow both objectives and constraints as criteria that the solution must satisfy, so the three concepts must be addressed separately. Hence the core concept in CSOPs is to assign a value to each of the variables from the variables’ domain such that not only the constraints are satisfied but also the set of optimization criteria are satisfied. Due to the structure of a CSOP, objectives cannot be realized directly, they must be realized via intermediate soft constraints. For example, in valued CSOPs, the criteria is to minimize (resp. maximize) the total value of the soft constraints. This requires soft constraints that return a real number, rather than true or false. Using optimization criteria such as minimize or maximize has other difficulties, as a naive solver must explore the entire solution space to determine if the criteria is satisfied. Furthermore, the relaxation of an over-constrained problem yields a CSOP. Over-constrained problems can be converted by either relaxing the constraints or the solutions. Relaxing the constraints yields an optimization criteria on the constraints (satisfy the maximum number of constraints). While relaxing the solutions means that some variables can be left without a value assigned, leading to the objective: maximize the number of variables assigned a value. If there exists more than one optimization criteria, then often there is no solution that satisfies all of them. So, the criteria is normally relaxed to find a pareto-optimal solution.



A unified formulation must also support the concept of agents. The concept of agents is required for distributed problems. An agent has knowledge of a subset of the entire problem and can only affect a subset of the sub-problem it knows. There are several common justifications (such as resource limits, privacy concerns and communication capacity) for limiting an agent's knowledge to only a subset of the entire problem. Furthermore, resource and communication limitations can lead to efficiencies, such as a reduction of memory requirements for each agent and a reduction in required messages to keep the knowledge of all agents synchronized. An agent may also not know of variables and constraints that represent privileged information held by another agent.

**DEFINITION 2.5.** *A Semiring-Based Distributed Constraint Satisfaction/Optimization Problem (SDCOP) is a tuple  $\langle \mathcal{A}, \mathcal{X}, \mathcal{D}, \mathcal{V}, \mathcal{C} \rangle$  where*

- $\mathcal{A}$  is a non-empty set of agents. An agent is a pair  $\alpha = \langle R_\alpha, W_\alpha \rangle$ .  $R_\alpha$  is a set of variables for which the agent has **read privileges**, and  $W_\alpha \subseteq R_\alpha$  is a set of variables for which the agent has **write privileges**.
- $\mathcal{X}$  is a set of variables.
- $\mathcal{D}$  is a set  $\{D_1, \dots, D_n\}$  where  $n = |\mathcal{X}|$  and each  $D_i$  is a set of values to be assigned to a variable (the domain).
- $\mathcal{V} = \langle V, \oplus, \otimes \rangle$  is an idempotent semiring utilized to evaluate variable assignments.
- $\mathcal{C}$  is a non-empty set of constraints, where each constraint  $c_i$  is a pair  $\langle def_i, con_i \rangle$  where  $def_i$  is a function  $def_i : (\bigcup \mathcal{D})^k \rightarrow V$  (where  $k = |con_i|$ ) and  $con_i \subseteq \mathcal{X}$  is the **signature** of constraint  $c_i$  (i.e., the set of variables referred to in that constraint).

*If an agent  $\alpha$  has write privileges for a variable  $v$ ,  $\alpha$  must also have read privileges for all variables which share a constraint with  $v$  i.e.  $\forall v \in W_\alpha, \forall c_i \in \mathcal{C}$ , if  $v \in con_i$ , then  $con_i \subseteq R_\alpha$ .*

The set of agents refers to the agents that must co-operate to solve the problem. There is of course much more to an agent than just its privileges, such as the amount of resources available or the 'temperament' of the agent. We do not consider those attributes (and similar ones) of agents as they only apply to solving the problem, not to the description of the problem.

Read privileges serve a dual purpose. The primary purpose is to identify which agents must know the value assigned of a variable. The secondary purpose is to determine the required communication links between agents. Knowledge of variable assignments is only one aspect of privacy. Often it is also desirable to ensure that other agents can not discover the constraints on an agent's variables. The flow of such information is entirely dependent on the algorithm and so is outside the scope of this work.

As the required communication is already prescribed by read privileges, the write privileges are purely to determine which agents have permission to allocate a value to a variable. In most situations, it is acceptable for there to be variables in the problem for which no agent has write privileges. These can be viewed as hard constraints or environmental constants. This concept is particularly useful in a mixed-initiative setting whereby assignments made by the human operator should not and cannot be overruled by the machine solver.

The explicit assertion of read/write privileges is unique to this formulation. Traditional formulations implicitly prescribe global read privileges while maintaining only local write privileges. We feel that this approach over simplifies real world problems. Such an assumption creates additional communication overhead to maintain synchronization and impedes on the scalable and distributed nature of DCSOPs. Furthermore, to honestly reflect the privacy property in DCOPs, the read/write privileges prescribes access control machinery to control access to information. However, note that the traditional formulation (global read/local write) approach is a special case for our formulation where agents are given read privileges to all variables. It also allows for parameters (variables for which no agent has write access) to be naturally represented within the problem and allows the community to explore problems without the simplifying assumption that agents have exclusive control over variables. Designing algorithms which support allowing multiple agents to write to a variable presents new challenges. The algorithm must have some mechanism for either managing access to the variable or resolving the resulting inconsistencies.

The definition of read and write privileges allows a graph representing the communication channels between agents to be defined. Each node in the graph represents an agent and there is an edge between two nodes if the respective agents must communicate. Two agents must communicate if they each control a variable which contributes to the same constraint or objective. To minimize communication bandwidth and privacy loss, the

communication channels between agents exist only in situations where the agents share variables. More formally,

**DEFINITION 2.6.** *Given a SDCOP  $\langle \mathcal{A}, \mathcal{X}, \mathcal{D}, \mathcal{V}, \mathcal{C} \rangle$ , a **neighbourhood graph** is a directed graph  $\langle N, E \rangle$  where  $N = \mathcal{A}$  and  $E \subseteq \mathcal{A} \times \mathcal{A}$  such that  $\forall \alpha, \alpha' \in \mathcal{A}, \langle \alpha, \alpha' \rangle \in E$  iff  $\alpha \neq \alpha' \wedge \exists x \in \mathcal{X}$  such that  $x \in W_\alpha \wedge x \in R_{\alpha'}$ .*

If an agent  $\alpha$  has write privileges to a variable  $x$  and another agent  $\alpha'$  has read privileges to  $x$  then they must be able to communicate, as  $\alpha$  must inform  $\alpha'$  of any changes it makes to  $x$ . If two agents must communicate then they are in the same neighbourhood.

Variables are identified by a unique name. All variables share the same domain, rather than having separate domains as per common practice. The common domain can be viewed as the union of all individual domains, with unary constraints on the individual variables restricting which subset of the domain values can be assigned to the variables. This approach generalizes existing practice. The idea of having the domain of each variable defined by unary constraints was discussed by Ross et. al. [18]

Our use of functions that return a value from an idempotent semiring allows for the representation of a range of different forms of constraints. In classic satisfaction problems, the semiring  $\langle \{\text{True}, \text{False}\}, \vee, \wedge \rangle$  is sufficient to reflect the satisfaction of the constraints. For valued constraint optimization problems, the semiring  $\langle \mathbb{R}, \min, + \rangle$  is suitable for minimization problems and  $\langle \mathbb{R}, \max, + \rangle$  is suitable for maximization problems. In the cases where there are multiple objective functions, each objective is represented by its own idempotent semiring. The  $\text{Comb}()$  operator can then be utilized to combine the individual semirings. Using this approach to combine the different objectives naturally leads to a search for a pareto-optimal solution. By using this approach we do not impose an ordering on the objectives, however an ordering can be added if so desired. Furthermore, such an approach also allows for all the different types of constraints to be combined.

We also distinguish between two classes of constraints: local constraints and shared constraints. A local constraint is known by only one agent and can only be evaluated by that agent. For this to occur one agent must have write privileges to all of the variables in  $\text{con}_i$  (refer to definition 2.5). Shared constraints are known by all agents which have write privileges to a variable in the constraints signature and can be evaluated by any one of those agents. This occurs when more than one agent has write privileges to one of the variables in  $\text{con}_i$  (refer to definition 2.5).

**DEFINITION 2.7.** *Given an SDCOP  $\langle \mathcal{A}, \mathcal{X}, \mathcal{D}, \mathcal{V}, \mathcal{C} \rangle$ ,  $\mathcal{S}$  is the set of all possible assignments to variables. Each assignment is a set of variable-value pairs where no variable appears more than once. We will refer to an assignment  $s \in \mathcal{S}$  as a **complete assignment** if it assigns a value to every variable in  $\mathcal{X}$ . For some assignment  $s \in \mathcal{S}$ , we will use  $s \downarrow_X$  to denote the projection of the assignment to a set of variables  $X$  (i.e., the subset of  $s$  that refers to variables in  $X$ ). Given an assignment  $s = \langle \langle x_1, v_1 \rangle, \langle x_2, v_2 \rangle, \dots, \langle x_k, v_k \rangle \rangle$ ,  $\text{val}(s) = \langle v_1, v_2, \dots, v_k \rangle$  and  $\text{var}(s) = \langle x_1, x_2, \dots, x_k \rangle$ .*

The different criteria are reflected in the definition of a solution to a SDCOP. The concept of a solution to a satisfaction problem is generalized in our definition of an acceptable solution.

Recall that our unified definition of a CSP is agnostic to the solving method, so while it has been shown [16] that combining semirings is not sufficient for solving multi-objective problems using inference based methods [1, 5, 6, 7, 15] (specifically the operators  $\oplus$  and  $\otimes$ ). However, combining semirings is sufficient for search based methods [2, 20], which are common in the DCOP literature. For this reason we define the solutions to a SDCOP in terms of the properties they must satisfy, which are independent of the solving method and the semiring used to evaluate assignments. Furthermore, we utilize a notion of acceptable threshold to define an acceptable solution to an optimization problem. The idea of an acceptable threshold on an optimization problem has been proposed by J. Larrosa [11].

**DEFINITION 2.8.** *An **acceptable solution** to a SDCOP with  $\mathcal{C} = \{c_1, \dots, c_n\}$  is a complete assignment  $s$  such that  $\text{def}_1(\text{val}(s \downarrow_{\text{con}_1})) \otimes \dots \otimes \text{def}_n(\text{val}(s \downarrow_{\text{con}_n})) \preceq_V v$ , where  $v \in V$  is a minimum threshold on the value of the solution.*

The solution to a classic satisfaction problem can be represented as an acceptable solution with a threshold of True. An acceptable solution is also useful to represent problems where the optimal solution is not required or it is too expensive to search for the optimal solution.

**DEFINITION 2.9.** *An **optimal solution** to a SDCOP with  $\mathcal{C} = \{c_1, \dots, c_n\}$  is a complete assignment  $s$  such that there does not exist another complete assignment  $s'$  where  $\text{def}_1(\text{val}(s' \downarrow_{\text{con}_1})) \otimes \dots \otimes \text{def}_n(\text{val}(s' \downarrow_{\text{con}_n})) \prec_V \text{def}_1(\text{val}(s \downarrow_{\text{con}_1})) \otimes \dots \otimes \text{def}_n(\text{val}(s \downarrow_{\text{con}_n}))$  (note:  $a \prec_V b$  iff  $a \preceq_V b$  and  $b \not\preceq_V a$ ).*

**THEOREM 2.10.** *At least one optimal solution exists for any SDCOP.*

*Proof.* The associative property of  $\oplus$  means that the ordering  $\preceq_V$  derived from  $\oplus$  is transitive. Due to the ordering being transitive, cycles can not exist within the ordering. Because there are no cycles there must be at least one abstract value which is not dominated by another abstract value.

The constraints map each assignment to exactly one abstract value, which is used to order the assignments. As such, the ordering over assignments is also transitive. Therefore there must be at least one complete assignment which is not dominated by another complete assignment.  $\square$

Note that the definition of an optimal solution is equivalent to a non-dominated solution, as such the set of all optimal solutions is the pareto-frontier. If an acceptable solution (for a given threshold) does not exist, one way to get a solution which is acceptable is to relax the concept of a solution. This is done by not requiring a complete solution to the SDCOP.

**DEFINITION 2.11.** *Given a constraint  $c_i = \langle def_i, con_i \rangle$  the projection of  $c_i$  onto a set of variables  $X$ ,  $c_i \downarrow_X = \langle def'_i, con_i \cap X \rangle$ . If  $con_i \subseteq X$  then  $c_i$  is returned unchanged.  $def'_i$  is defined such that for a given input  $V$  it returns one of the values  $def_i$  can return for the input  $V$  expanded to include values for the other variables in  $con_i$ .*

There are two different intuitions about which value to return in the projected version of the constraint. First, the projected constraint should return the best possible value using the assigned variables. Second, the projected constraint should return the worst possible value using the assigned variables. It is possible that there is more than one best or worst value, as the semiring allows a partial ordering. In this case the choice between the best or worst values is arbitrary.

**DEFINITION 2.12.** *Given a set of constraints  $\mathcal{C} = \{c_1, \dots, c_n\}$  and an assignment  $s$ , let  $\mathcal{C}' = \{c_1 \downarrow_{var(s)}, \dots, c_n \downarrow_{var(s)}\}$ .  $s$  is a **relaxed solution** with reference to the constraints  $\mathcal{C}'$  iff  $def_1(val(s \downarrow_{con_1})) \otimes \dots \otimes def_n(val(s \downarrow_{con_n})) \preceq_V v$ , where  $v$  is a minimum threshold on the value of the solution and there does not exist another assignment  $s'$  where  $|s'| > |s|$  and  $def_1(val(s' \downarrow_{con_1})) \otimes \dots \otimes def_n(val(s' \downarrow_{con_n})) \preceq_V v$ .*

There are many other ways to define a solution to a SDCOP, such as a  $k$ -optimal solution [13]. These other solution concepts can be easily modified for the SDCOP structure.

**2.3. Example Instantiations.** In this section, we will illustrate the usefulness of our framework by the SDCOP instances that correspond to several common DCOPs. We will do so by presenting three instantiations: a CSP instance, a DCOP instance and a DCOP variation. Bistarelli's c-semiring framework [3] is one of the commonly accepted frameworks for generalizing CSP problems. Both Bistarelli's c-semiring framework and our SDCOP framework are based on using a variation of a semiring to order the solutions. As highlighted earlier, CSPs are special instances of DCOPs. Hence, it is befitting to illustrate the generality of SDCOP by demonstrating Bistarelli's c-semiring framework is a special instance of an SDCOP.

**THEOREM 2.13.** *Any problem represented as a c-semiring can be represented as an idempotent semiring. Any idempotent semiring which also satisfies the following properties can be represented as a c-semiring.*

- $\perp_i \in V$  is the absorbing element of  $\otimes$  and the unit element of  $\oplus$ .
- $\top_i \in V$  is the unit element of  $\otimes$  and the absorbing element of  $\oplus$ .

*Proof.* We consider two representations of a constraint optimisation problem to be equivalent iff the solutions of the representations are equal. The solution to a constraint optimisation problem is defined in terms of the  $\oplus$  and  $\otimes$  operators. Therefore it is sufficient to show that the  $\oplus$  and  $\otimes$  operators in c-semirings and idempotent semirings have the same properties.

Given a c-semiring  $\langle V_c, \oplus_c, \otimes_c, \perp_c, \top_c \rangle$  and an idempotent semiring  $\langle V_i, \oplus_i, \otimes_i, \perp_i, \top_i \rangle$  as described above, we show that the two are equivalent.

$V_i$  and  $V_c$  are equivalent by definition, as are  $\otimes_i$  and  $\otimes_c$ .  $\perp_i, \perp_c$  are the absorbing elements of  $\otimes_i, \otimes_c$  respectively, as per the definition. Similarly  $\top_i, \top_c$  are the unit elements of  $\otimes_i, \otimes_c$  respectively.

It remains to show that  $\oplus_i$  is equivalent to  $\oplus_c$ .  $\oplus_c$  is defined over a set of operands, while  $\oplus_i$  is strictly a binary operator, as such the behaviour of  $\oplus_c$  with zero or one operands is not relevant.  $\oplus_i$  is commutative, associative and idempotent, so it follows that  $\oplus_i(\{v_i, v_{i+1}, \dots, v_j\}) = v_i \oplus v_{i+1} \oplus \dots \oplus v_j$  for all sets of indices  $i, i+1, \dots, j$ . It is shown in Bistarelli's paper that  $\oplus_c$  is idempotent, commutative and associative. By specifying that  $\top$  is the absorbing element of  $\oplus_i$ ,  $v_1 \oplus v_2 \oplus \dots \oplus v_n = \top$  for  $v_1, \dots, v_n \in V$ , which is equivalent to  $\oplus_c(V) = \top_c$ .  $\oplus_i(\mathcal{V}) = \top$  will be the case iff  $\top$  is the absorbing element of  $\mathcal{V}$ .  $\square$

We have just shown that the idempotent semiring used in our framework is more general than the c-semiring used in Bistarelli's framework [3]. Therefore, all the constraint schemes which can be represented in Bistarelli's framework can also be represented in our framework. Namely classical, fuzzy, probabilistic, weighted (minimization), set based, and multi-objective constraint optimization problems.

There exists several formulations of DCOPs [2, 7, 12, 14, 20]. All of these formulations capture the important aspects of DCOPs equally well. We will focus on the instantiation of Petcu's formulation [14] into SDCOP as it is the most formal definition.

Petcu [14] defines a COP as follows:

DEFINITION 2.14. [14] A discrete constraint optimization problem (COP) is a tuple  $\langle \mathcal{X}, \mathcal{D}, \mathcal{R} \rangle$  such that:

- $\mathcal{X} = \{X_1, \dots, X_n\}$  is a set of variables (e.g. start times of meetings);
- $\mathcal{D} = \{d_1, \dots, d_n\}$  is a set of discrete, finite variable domains (e.g. time slots);
- $\mathcal{R} = \{r_1, \dots, r_m\}$  is a set of utility functions, where each  $r_i$  is a function with the scope  $(X_{i_1}, \dots, X_{i_k})$ ,  $r_i : d_{i_1} \times \dots \times d_{i_k} \rightarrow \mathbb{R}$ . Such a function assigns a utility (reward) to each possible combination of values of the variables in the scope of the function. Negative amounts mean costs. Hard constraints (which forbid certain value combinations) are a special case of utility functions, which assign 0 to feasible tuples, and  $-\infty$  to infeasible ones;

DEFINITION 2.15. [14] A discrete distributed constraint optimization problem (DCOP) is a tuple of the following form:  $\langle \mathcal{A}, \mathcal{COP}, \mathcal{R}^{ia} \rangle$  such that:

- $\mathcal{A} = \{A_1, \dots, A_k\}$  is a set of agents (e.g. people participating in meetings);
- $\mathcal{COP} = \{COP_1, \dots, COP_n\}$  is a set of disjoint, centralized COPs; each  $COP_i$  is called the local sub-problem of agent  $A_i$ , and is owned and controlled by agent  $A_i$ ;
- $\mathcal{R}^{ia} = \{r_1, \dots, r_n\}$  is a set of inter-agent utility functions defined over variables from several different local sub-problems  $COP_i$ . Each  $r_i : d_{i_1} \times \dots \times d_{i_k} \rightarrow \mathbb{R}$  expresses the rewards obtained by the agents involved in  $r_i$  for some joint decision. The agents involved in  $r_i$  have full knowledge of  $r_i$  and are called 'responsible' for  $r_i$ . As in a COP, hard constraints are simulated by utility functions which assign 0 to feasible tuples, and  $-\infty$  to infeasible ones;

Further, Petcu defines a solution as:

DEFINITION 2.16. [14] The goal is to find a complete instantiation  $\mathcal{X}$  for the variables  $X_i$  that maximizes the sum of utilities of individual utility functions. The definition of a solution provided by Petcu [14] corresponds to the definition of an optimal solution within SDCOP. This definition of a DCOP corresponds to the following SDCOP:

THEOREM 2.17. Petcu's definition of a DCOP is a SDCOP  $\langle \mathcal{A}, \mathcal{X}, \mathcal{D}, \mathcal{V}, \mathcal{S}, \mathcal{C} \rangle$  with the additional properties:

- Exactly one agent has write access for each variable.
- $\bigcup \mathcal{D}$  is finite.
- $\mathcal{V} = \langle \mathbb{R}, \max, + \rangle$ .

*Proof.* The two formulations are equivalent iff every problem that can be described by Petcu's definition has an equivalent definition within the SDCOP and every problem that can be described by the SDCOP has an equivalent definition within Petcu's definition.

We start by showing that every problem that can be described by Petcu's definition has an equivalent definition within the SDCOP. It is clear that both formulations support the concept of agents. Petcu's definition allows an agent to control a set of variables described as a sub-problem while SDCOP directly specifies the variables that an agent controls. Petcu's use of real numbers to measure utility can easily be represented by the idempotent semiring  $\langle \mathbb{R}, \max, + \rangle$

Now we show that every problem that can be described by the SDCOP has an equivalent definition within Petcu's definition. Both definitions support the concept of agents. The first additional restriction on a SDCOP results in each agent controlling a distinct set of variables. The variables which an agent controls form the agent's sub-problem in Petcu's definition. There is no formal concept of read privileges in Petcu's definition, instead it is simply assumed that if an agent knows a constraint, it has read privileges for all variables in the constraint, which is the minimal read privileges required for SDCOP. SDCOP uses a single domain for all variables, as opposed to separate finite domains for each variable. The second restriction limits SDCOP to a finite domain, which can be transformed into variable specific domains by first assigning each variable the

entire domain, then propagating all the unary constraints on that variable. The resulting domain is specific domain for that variable. After this the unary constraints can be removed. Restriction three limits SDCOP to using real numbers as the utility, which is equivalent to Petcu's use of real numbers. Finally the use of n-ary constraints in SDCOP is almost identical to the constraints in Petcu's definition.  $\square$

Recently, Grinshpoun et al. proposed the Asymmetrical DCOP (ADCOP) model [8]. In this model, the utility gained by each agent participating in a constraint is tallied separately, however the objective is to minimize (maximize) the sum of the utilities of all agents. The motivation is to preserve the privacy of each agent regarding its local utility. Grinshpoun et al. [8] define a DCOP as follows:

**DEFINITION 2.18.** [8] *A DCOP is a tuple  $\langle \mathcal{A}, \mathcal{X}, \mathcal{D}, \mathcal{R} \rangle$ .  $\mathcal{A}$  is a finite set of agents  $A_1, A_2, \dots, A_n$ .  $\mathcal{X}$  is a finite set of variables  $X_1, X_2, \dots, X_m$ . Each variable is held by a single agent (an agent may hold more than one variable).  $\mathcal{D}$  is a set of domains  $D_1, D_2, \dots, D_m$ . Each domain  $D_i$  contains a finite set of values which can be assigned to variable  $X_i$ .  $\mathcal{R}$  is a set of relations (constraints). Each constraint  $C \in \mathcal{R}$  defines a non-negative cost for every possible value combination of a set of variables, and is of the form:*

$$C : D_{i_1} \times D_{i_2} \times \dots \times D_{i_k} \longrightarrow \mathbb{R}^+ \quad (2.1)$$

Grinshpoun et al. [8] define an ADCOP as follows:

**DEFINITION 2.19.** [8] *An ADCOP is defined by the following tuple  $\langle \mathcal{A}, \mathcal{X}, \mathcal{D}, \mathcal{R} \rangle$ , where  $\mathcal{A}$ ,  $\mathcal{X}$ , and  $\mathcal{D}$  are defined in exactly the same manner as in DCOPs. Each constraint  $C \in \mathcal{R}$  of an asymmetric DCOP defines a set of non-negative costs for every possible value combination of a set of variables, and takes the following form:*

$$C : D_{i_1} \times D_{i_2} \times \dots \times D_{i_k} \longrightarrow \mathbb{R}^{+k} \quad (2.2)$$

Grinshpoun's definition of a DCOP is comparable to Petcu's, which we have already shown to be an instance of an SDCOP. It remains to show that the constraint definition in an ADCOP is an instance of an idempotent semiring.

**THEOREM 2.20.** *Asymmetrical constraints as defined in a ADCOP can be represented as the an idempotent semiring  $\langle V, \otimes, \oplus \rangle$  where:  $V$  is the Cartesian product of the set of utilities for each agent.  $\mathbb{R}_+^n$ , given agents  $a_1, \dots, a_n$ ,  $\otimes$  is defined as  $\otimes(v, v') = \langle v_1 + v'_1, v_2 + v'_2, \dots, v_n + v'_n \rangle$  and  $\oplus$  is defined as*

$$\oplus(v, v') = \begin{cases} v & \Sigma_n^1 v \leq \Sigma_n^1 v' \\ v' & \text{otherwise} \end{cases} \quad (2.3)$$

*In addition, if there does not exist a variable which is owned by an agent  $\alpha$ , in the signature of a constraint  $c$ , then the cost for  $\alpha$  in the result of the constraint  $c$  must be zero.*

*Proof.*

The ADCOP definition allows the cost for each agent to be recorded separately, by having one integer/real number for each agent, the idempotent semiring described also allows the cost for each agent to be recorded separately. The aggregation operator in ADCOP is sum, with the cost for each agent aggregated separately, this is reflected in the  $\otimes$  operator. The comparison operator in ADCOP is a utilitarian minimization operator, this is reflected in the  $\oplus$  operator.

The idempotent semiring always includes a cost for all agents, even if the agent is not involved in the constraint, thus it may represent constraints that can't be represented in an ADCOP. The restriction on the cost for an agent if the agent is not part of the constraint prevents this case.  $\square$

**3. Semi-Ring Support Based Distributed Optimisation.** The Support Based Distributed Optimisation (SBDO) algorithm [2], which this algorithm extends, is intended to be deployed in real life environments. We characterise real life environments as having the following properties:

- Dynamic
- Anarchic
- Unreliable agents/communication

- Hetrogeneous agents
- Selfish agents
- Malicious agents

These are in addition to the properties of the problem, such as different constraint types and multiple objectives.

In order to operate in this environment, we identified three ideals that the algorithm should meet. These are autonomy, equity, and fault tolerance. Autonomy means that the agent retains control of its local knowledge and has the power to act or not act as its situation dictates. Equity means that each agent has the same influence over the final solution and requires a similar amount of resources to the other agents. Fault tolerance means that the overall system should not fail when any of its components fails.

In order to attempt to meet these ideals, SBDO is based on negotiation/argumentation between the agents, rather than a power structure as commonly used. Because of this, the agents have equal power over the other agents and the final solution to the problem. In the process of solving the problem, the agents dynamically form coalitions and use their combined power to influence the other agents. These coalitions are determined based on the structure of the problem and random chance, rather than any bias in the algorithm. The lack of an enforced structure means that the algorithm is not unduly affected should an agent fail, and can continue attempting to solve the problem without the failed agent. The redundancy built into the message passing means that an agent which fails can be recovered quickly. The communication protocol used is also not sensitive to messages arriving in the wrong order. Together these make the algorithm tolerant of a variety of different faults.

The version of SBDO described in this chapter can solve SDCOP problems which meet the following conditions:

- The domain of variables ( $\bigcup \mathcal{D}$ ) must be finite.
- The quality of a solution must be monotonically non-decreasing as the solution is extended, i.e.  $\forall a, b \in V, a \otimes b \preceq a$ .

How SBDO and SBDOsr support dynamic problems is discussed in earlier publications [2], so is not discussed here.

We start our discussion of the SBDOsr algorithm by defining the messages sent between agents.

**DEFINITION 3.1.** An **assignment** is a triple  $\langle a, v, u \rangle$  where  $a$  is an agent in the SDCOP,  $v$  is a set of variable-value pairs, and  $u$  is the utility of this assignment returned by the agents local constraints.  $v$  must contain a variable-value pair for every variable in  $W_a$  for which another agent has read privileges.

**DEFINITION 3.2.** Given an SDCOP  $= \langle \mathcal{A}, \mathcal{X}, \mathcal{D}, \mathcal{V}, \mathcal{C} \rangle$ , a **proposal** is a pair  $\langle VA, SCE \rangle$ , where  $VA$  (variable assignments) is a sequence  $\langle ass_1, \dots, ass_n \rangle$  of assignments such that the sequence of agents forms a simple path through the neighbourhood graph and there are no conflicting assignments.  $SCE$  (shared constraint evaluations) is a set of evaluations of shared constraints. A shared constraint can only be evaluated if an assignment to every variable involved in the constraint is included in  $VA$ . Each evaluation is a tuple  $\langle o, u \rangle$  where  $o$  is a shared objective and  $u$  is the utility returned by the objective function  $o$  given the assignments in  $VA$ .

As an example, consider the two agents A and B, who share a constraint O, as well as having their own local constraints. When A first creates a proposal it simply contains an assignment to A,  $\langle \langle \langle A, \{ \langle a, 1 \rangle \}, 3 \rangle \rangle, \{ \} \rangle$ . Later when B extends the proposal, B then has enough information to evaluate the shared objective, producing  $\langle \langle \langle A, \{ \langle a, 1 \rangle \}, 3 \rangle, \langle B, \{ \langle b, 2 \rangle \}, 2 \rangle \rangle, \{ \langle O, 10 \rangle \} \rangle$ .

The sequence of variable assignments indicates the order in which this proposal has been constructed and is required both to store the utility of the solution and for the generation of nogoods. The set of shared constraint evaluations is required to record the utility of constraints shared by more than one agent. If the utility of the shared constraints is combined with the local constraints they might be double counted when cycles form. Note that in situations where privacy is important, the assignment to a variable only needs to be disclosed if another agent has a constraint involving this variable.

The utility of an assignment can be determined by evaluating the applicable functions in  $\mathcal{C}$  and aggregating them using  $\otimes$ . The total utility of an proposal is determined by applying the aggregation ( $\otimes$ ) operator over the utility of each assignment and evaluation. As such a proposal encodes a partial solution to the problem as well as the relative utility of the partial solution. When a proposal is considered as an argument the first  $n - 1$  assignments form the justification and the last assignment is the conclusion.

The utility value provides a partial order over the the proposals (partial solutions). Comparison between proposals can be performed by first applying the  $\otimes$  operator over the utility of each assignment and evaluation to determine its utility value and then the  $\oplus$  operator to determine which proposal is better. Whenever we refer to one proposal being better than another in this paper it is with respect to this induced ordering.

The counterpart of a proposal is a nogood. A nogood represents a partial solution that violates at least one constraint and should never be reconsidered or included in the final solution. This inconsistency is discovered when the utility of an isgood is  $\perp$ . Nogoods with justifications [19] are used as these allow us to guarantee that all the hard constraints are satisfied (as shown in [10]) as well as allowing obsolete nogoods to be identified after the constraints that the nogood violated are removed from the problem. For our purposes, a nogood with justification (originally defined in [19]) is treated as follows:

**DEFINITION 3.3.** *Given an SDCOP  $\langle \mathcal{A}, \mathcal{X}, \mathcal{D}, \mathcal{V}, \mathcal{C} \rangle$ , a **nogood** is a pair  $\langle P, C \rangle$  where  $P$  is a set of variable-value pairs representing a partial solution and  $C \subseteq \mathcal{C}$  is the set of constraints that provides the **justification** for the nogood, such that the combination of  $s$  and  $C$  is inconsistent (results in  $\perp$ ).*

*A **minimal nogood** is a nogood  $n = \langle P, C \rangle$  such that there does not exist a nogood  $n' = \langle P', C' \rangle$  where  $P' \subset P$  or a nogood  $n'' = \langle P, C'' \rangle$  where  $C'' \subset C$ .*

In static environments, detecting that the network has reached a quiescent state is sufficient to detect termination. This can be achieved by taking a consistent global snapshot [4]. The algorithm will also terminate if it detects that there is no solution to the problem, by generating the empty nogood. Otherwise, due to the dynamic nature of the input problem, the algorithm will only terminate when instructed to by an outside entity. Detecting that the network of agents has reached a quiescent state, or detecting that the problem is over-constrained are in themselves insufficient as terminating criteria, since new inputs from the environment, in the form of added or deleted variables/constraints might invalidate them.

---

**Algorithm 1** send\_nogood(I)

---

```

Let N be a nogood derived from I
Send N to A
Delete I

```

---



---

**Algorithm 2** process\_remove\_nogood\_message

---

```

Let C be the constraint referenced
for Each received nogood N do
  if N is in the remove_nogood_message then
    Delete N from nogoods
    delete N from the remove_nogood_message
if counter  $\neq$  0 then
  Add the remove_nogood_message to removed-constraints
receive remove_constraint(C)

```

---

**3.1. Algorithm.** The core of SSBDO is very simple. First the agent reads any messages it has received from other agents and updates its knowledge. If it has received a proposed solution from another agent that is inconstant, it responds with a nogood message. Second it chooses an assignment for all variables for which it has write privileges. Third the agent sends a message to each of its neighbours, informing them of any change to its proposals. Finally the agent waits until it receives new messages.

All agents continue in this fashion until all their proposals are consistent. When this happens all agents will no longer send any new messages, as their proposed solutions don't change. If deployed in a static environment, termination can be detected by taking a consistent global snapshot [4]. Otherwise they continue to wait until they are informed that the environment has changed, or they are requested to terminate.

Because there is no ordering defined over the agents, this algorithm can very easily adapt to changes in the problem, such as adding or removing constraints. It also degrades gracefully when agents fail, making the

**Algorithm 3** process remove-constraint message

---

```

Let C be the removed constraint
for Each neighbour A do
  for Each nogood N sent to A do
    Let obsolete = {}
    if N contains C as part of its justification then
      Add N to obsolete
      Delete N from sent-nogoods
  if |obsolete| > 0 then
    Let M be a new remove-constraint message with C and nogoods
    Send M to A
for Each received nogood N do
  if N contains C as part of its justification then
    Mark N as obsolete

```

---

overall system fault tolerant.

In order to generalize SBDO to support SDCOP, agents have been adapted to maintain more than one proposed solution at a time. This allows the algorithm to find many solutions in one execution. Changing the agents **view** from a single proposal to a set of proposals requires changes to the way the agents **view** is created as well as how proposals are sent to other agents. After these changes the information an agent  $\gamma$  stores is:

- **support** The agent that  $\gamma$  is using as the basis for almost all decisions it makes. The **support**'s beliefs about the world (its **view**) are considered to be facts.
- **view** This is a set of proposals consisting of the proposals received from **support** with an assignment to  $\gamma$ 's variables appended. This represents the  $\gamma$ 's current beliefs about the world, or its world view.
- **recv(A)** This is a mapping from an agent  $\alpha$  to the last set of proposals received from  $\alpha$ . This stores the other agents most recent arguments.
- **nogoods** This is an unbounded multi-set of all current nogoods received. It contains pairs (sender, nogood).
- **sent(A)** This is a mapping from an agent  $\alpha$  to the last set of proposals sent to  $\alpha$ . This stores the arguments most recently sent to the agents neighbours.
- **sent-nogoods** This is an unbounded set of all nogoods sent by  $\gamma$ . It contains pairs (destination, nogood).
- **removed-constraints** An unbounded set of known obsolete nogoods. This stores references to all the nogoods that are known to be obsolete, but have not yet been deleted.
- **constraints** A set of all constraints  $\gamma$  knows. It must include all of an agent's local constraints and all constraints this agent shares with other agents.

As with SBDO each agent must first update its **view** based on its current **support**, as new information may have made its current **view** obsolete. The approach used in SBDO is to choose the neighbour that has sent the best proposal as this agents **support**, which clearly does not apply to SSBDO. Instead the agent that has sent the largest number of non-dominated proposals is chosen as this agents **support**. Specifically, all proposals this agent knows of, i.e. those it has received from its neighbours and those it has generated as its current **view**, are considered. Out of those proposals the set of non-dominated proposals is computed and they are partitioned based on their source. If the source of the largest partition is this agents **view**, then this agents **support** does not change. Otherwise this agent changes its **support** to the agent which is the source of the largest partition. If there is a tie for the largest partition, it is broken by considering the following criteria, in lexicographical order:

1. Largest number of proposals received from each source.
2. Largest total length of received proposals from each source.
3. Consistent random choice. i.e. if the set of proposals A is preferred over the set of proposals B, A will



**Algorithm 4** main()

---

```

while Not Terminated do
  for all received nogoods N do
    if this nogood is obsolete then
      decrement counter on the removed-constraint message
    if counter = zero then
      delete constraint-removed message
    else
      Add N to nogoods
      for all neighbours A do
        if There is no valid assignment to myself wrt recv(A) then
          send_nogood(A)
  for all received environment messages do
    Process message
  for All received sets of proposals  $S_i$  do
    Let A be the agent who sent I
    Set recv(A) to I
    for Each proposal I in  $S_i$  do
      if There is no valid assignment to myself wrt I then
        send_nogood(A)
  Set view to the non-dominated sub-set of all consistent extensions to all received proposals
  for All neighbours A do
    Set proposed_proposals to an empty set
    for Each proposal I in view do
      if I is part of a cycle then
        if I is dominated by an proposal in recv(A) then
          Postpone this proposal
        else
          Add I to proposed_proposals
      else
        Set preferred such that it meets the criteria
        Set I' to a tail of I, such that the length of I is min(max_length, preferred)
        add I' to proposed_proposals
    if proposed_proposals  $\neq$  sent(A) then
      Set sent(A) to proposed_proposals
      Send proposed_proposals to A
  Wait until at least one message has been received

```

---

always be preferred over  $B^1$ .

To illustrate this procedure, consider an agent  $\alpha$  which has received the following proposals from it's neighbour  $\beta$ :

- $\langle\langle\epsilon, \{e, 0\}\rangle, (3, 0)\rangle, \langle\beta, \{b, 1\}\rangle, (0, 3)\rangle, \{\}$  with a total utility of (3, 3).
- $\langle\langle\gamma, \{c, 0\}\rangle, (2, 1)\rangle, \langle\epsilon, \{e, 1\}\rangle, (0, 3)\rangle, \langle\beta, \{b, 1\}\rangle, (0, 3)\rangle, \{\}$  with a total utility of (2,7).

$\alpha$  has also received the following proposals from it's neighbour  $\gamma$ :

- $\langle\langle\epsilon, \{e, 0\}\rangle, (3, 0)\rangle, \langle\gamma, \{c, 0\}\rangle, (2, 1)\rangle, \{\}$  with a total utility of (5,1).

Finally,  $\alpha$ 's **view** consists of the following proposals:

- $\langle\langle\gamma, \{c, 1\}\rangle, (1, 2)\rangle, \langle\alpha, \{a, 1\}\rangle, (0, 3)\rangle, \{\}$  with a total utility of (1,5).

---

<sup>1</sup>Hash functions can provide a suitable comparison.

- $\langle\langle\gamma, \{\langle c, 1 \rangle\}, (1, 2)\rangle, \langle\alpha, \{\langle a, 0 \rangle\}, (3, 0)\rangle\rangle, \{\}$  with a total utility of (4,2).

Given this information, the set of non-dominated proposals are:

- $\langle\langle\epsilon, \{\langle e, 0 \rangle\}, (3, 0)\rangle, \langle\beta, \{\langle b, 1 \rangle\}, (0, 3)\rangle\rangle, \{\}$  with a total utility of (3, 3).
- $\langle\langle\gamma, \{\langle c, 0 \rangle\}, (2, 1)\rangle, \langle\epsilon, \{\langle e, 1 \rangle\}, (0, 3)\rangle, \langle\beta, \{\langle b, 1 \rangle\}, (0, 3)\rangle\rangle, \{\}$  with a total utility of (2,7).
- $\langle\langle\epsilon, \{\langle e, 0 \rangle\}, (3, 0)\rangle, \langle\gamma, \{\langle c, 0 \rangle\}, (2, 1)\rangle\rangle, \{\}$  with a total utility of (5,1).
- $\langle\langle\gamma, \{\langle c, 1 \rangle\}, (1, 2)\rangle, \langle\alpha, \{\langle a, 0 \rangle\}, (3, 0)\rangle\rangle, \{\}$  with a total utility of (4,2).

One of the non-dominated proposals originate from  $\alpha$ , two originate from  $\beta$  and one from  $\gamma$ . This will cause  $\alpha$  to change its **support** to  $\beta$ . If there was a tie between  $\alpha$  and  $\beta$ , then  $\alpha$  would win, as it has three total proposals compared to  $\beta$ 's two. In the case of a tie between  $\beta$  and  $\gamma$ ,  $\beta$  would win, as the total length of its proposals is five compared to  $\gamma$ 's four.

In the case of SBDO, where there is at most one proposal from each source, there is normally only one proposal in the non-dominated set. It is possible for two (or more) proposals with equal utility to form the non-dominated set. When this happens the tie breaking procedure is equivalent in SSBDO and in SBDO.

If this agents **support** has changed, then it must re-compute its **view**. To generate its **view**, this agent extends the proposals it has received from its **support**. For each proposal it has received from its support, this agent computes the set of non-dominated proposals which can be generated by extending the received proposal with an assignment to this agent. If the agent changes the value of a variable which already has a value assigned to it in this proposal (i.e. more than one agent has write privileges), it must trim the proposal such that there are not two different values assigned to the same variable. The resulting reduction in the total utility of the proposal ensures that variables which have already been assigned by another agent will only be changed if there is significant benefit in doing so.

The procedure in SBDO for updating an agent's neighbours assumes that one proposal has been sent to and received from each neighbour. It must be generalized for sending sets of proposals, taking care to ensure the properties required for the proof of termination and completeness still hold. These are: postponing of proposals that are involved in a cycle, sending a new proposal if this agent is in conflict with the destination agent and not sending a new message if the content has not changed since the last message.

As with SBDO, each proposal is treated individually, then the proposals that will be sent to this neighbour are grouped and sent in one message. Cycle elimination is the same as in SBDO. If there are two consecutive assignments in the received proposal which were generated by this agent and the destination agent respectively, then this proposal is part of a cycle. If the proposal is dominated by one of the proposals previously sent to the destination agent then it must not be sent at this time. Instead the proposal which dominates it should be resent. If the proposal dominates all of the previously sent proposals, then the entire proposal should be sent. Otherwise, when neither proposal dominates the other, both should be sent. If the proposal is not part of a cycle the next consideration is how much of the proposal to send to the destination agent. The proposal must be long enough to meet the following criteria:

1. If one of the proposals previously sent to the destination agent is a sub-proposal of this proposal, then this proposal is an update. In which case the length of the newly sent proposal should be the length of the previously sent proposal +1.
2. It must contain enough assignments to evaluate shared objectives/constraints. Specifically, if there exists a constraint/objective involving at least the destination agent B and another agent C in this agents' view, then the proposal must contain the assignment to C.
3. If the assignment to A is not consistent with any proposal received from B, then A should send a counter-proposal that is more preferred than the conflicting proposal.
4. The proposal should be equal to or longer than the shortest proposal previously sent to B.

It is not always possible to send a proposal of the desired length, as the length of the sent proposal is limited by the length of the proposal in **view**. Once the correct length of the proposal has been decided a new proposal is created. Once all proposals in **view** have been considered, the new proposals are checked against the proposals previously sent to this agent. If any of them have changed a proposal message is sent to the destination agent containing all of the proposals.

To illustrate this procedure, again consider an agent  $\alpha$ .  $\alpha$ 's **view** is currently:

•

$$\langle\langle\langle\beta, \{\langle b, 0 \rangle\}, (2, 0)\rangle, \langle\epsilon, \{\langle e, 1 \rangle\}, (0, 3)\rangle, \langle\gamma, \{\langle c, 0 \rangle\}, (2, 1)\rangle, \langle\alpha, \{\langle a, 1 \rangle\}, (0, 3)\rangle\rangle, \{\}\rangle$$

with a total utility of (4,7).

•

$$\langle\langle\langle\epsilon, \{\langle e, 1 \rangle\}, (0, 3)\rangle, \langle\gamma, \{\langle c, 1 \rangle\}, (1, 2)\rangle, \langle\alpha, \{\langle a, 1 \rangle\}, (0, 3)\rangle\rangle, \{\}\rangle$$

with a total utility of (1,8).

•

$$\langle\langle\langle\gamma, \{\langle c, 0 \rangle\}, (2, 1)\rangle, \langle\alpha, \{\langle a, 0 \rangle\}, (3, 0)\rangle\rangle, \{\}\rangle$$

with a total utility of (5, 1).

Further,  $\alpha$  has previously sent the following proposals to  $\beta$ :

•

$$\langle\langle\langle\beta, \{\langle b, 1 \rangle\}, (0, 3)\rangle, \langle\epsilon, \{\langle e, 0 \rangle\}, (3, 0)\rangle, \langle\gamma, \{\langle c, 1 \rangle\}, (1, 2)\rangle, \langle\alpha, \{\langle a, 0 \rangle\}, (3, 0)\rangle\rangle, \{\}\rangle$$

with a total utility of (7,5).

•

$$\langle\langle\langle\gamma, \{\langle c, 0 \rangle\}, (2, 1)\rangle, \langle\alpha, \{\langle a, 0 \rangle\}, (3, 0)\rangle\rangle, \{\}\rangle$$

with a total utility of (5,1).

Finally,  $\alpha$  has received (along with other proposals) the following proposal from  $\beta$ :

$$\langle\langle\langle\epsilon, \{\langle e, 0 \rangle\}, (3, 0)\rangle, \langle\gamma, \{\langle c, 1 \rangle\}, (1, 2)\rangle, \langle\alpha, \{\langle a, 0 \rangle\}, (3, 0)\rangle, \langle\beta, \{\langle b, 1 \rangle\}, (0, 3)\rangle, \rangle, \{\}\rangle$$

with a total utility of (7, 5).

We can see that the proposal received from  $\beta$  contains an assignment to  $\alpha$  then an assignment to  $\beta$ , as such they are part of a cycle. The first proposal in  $\alpha$ 's view has assignments to the same variables in the same order as the proposal received from  $\beta$ , so it might need to be postponed. Neither proposal dominates the other, so both proposals are sent to  $\beta$ . The second proposal in  $\alpha$ 's view is an update to the second proposal  $\alpha$  sent previously, so a slightly longer subset of that proposal is sent to  $\beta$ . Finally, the third proposal is new, so  $\alpha$  attempts to send a length three version of it, but as it is only length two, the entire proposal is sent. Therefore the new proposal message  $\alpha$  sends to  $\beta$  is:

•

$$\langle\langle\langle\beta, \{\langle b, 1 \rangle\}, (0, 3)\rangle, \langle\epsilon, \{\langle e, 0 \rangle\}, (3, 0)\rangle, \langle\gamma, \{\langle c, 1 \rangle\}, (1, 2)\rangle, \langle\alpha, \{\langle a, 0 \rangle\}, (3, 0)\rangle\rangle, \{\}\rangle$$

with a total utility of (7,5).

•

$$\langle\langle\langle\beta, \{\langle b, 0 \rangle\}, (2, 0)\rangle, \langle\epsilon, \{\langle e, 1 \rangle\}, (0, 3)\rangle, \langle\gamma, \{\langle c, 0 \rangle\}, (2, 1)\rangle, \langle\alpha, \{\langle a, 1 \rangle\}, (0, 3)\rangle\rangle, \{\}\rangle$$

with a total utility of (4,7).

•

$$\langle\langle\langle\epsilon, \{\langle e, 1 \rangle\}, (0, 3)\rangle, \langle\gamma, \{\langle c, 1 \rangle\}, (1, 2)\rangle, \langle\alpha, \{\langle a, 1 \rangle\}, (0, 3)\rangle\rangle, \{\}\rangle$$

with a total utility of (1,8).

•

$$\langle\langle\langle\gamma, \{\langle c, 0 \rangle\}, (2, 1)\rangle, \langle\alpha, \{\langle a, 0 \rangle\}, (3, 0)\rangle\rangle, \{\}\rangle$$

with a total utility of (5, 1).

The procedure for determining the length of each proposal to send is the same as in SBDO. However there are some changes due to it acting on two sets of proposals, rather than two proposals. First, for each new proposal, it is not clear which old proposal it should be compared with. In this case it is compared with all of them and the longest required proposal is sent. Further, when a proposal is postponed, the old version of the proposal must be sent. Otherwise the proposal will be lost when the destination agent updates its received proposals. Finally, an updated proposal message must be sent when any of the individual proposals change.

The changes made to the procedure for sending updates to an agents neighbours invalidate the proof of termination for SBDO. Here we present a generalization of the proof of termination for SBODsr. This is based on the proof of termination for SBDS [9].

**LEMMA 3.4.** *If no new nogoods are generated, then eventually the utility of view will become stable for each agent.*

*Proof.* Let  $W_i \subseteq \mathcal{X}$  be the set of agents whose view dominates  $i \in \mathcal{Z}$  of the possible solutions to the problem. An agent's view  $v$  dominates a solution  $s$  iff there exists a proposal  $p \in v$  such that the utility of  $p$  is greater than or equal to the utility of  $s$  (not less than or incomparable). We will prove that any decrease in  $|W_i|$  must be preceded by an increase in  $|W_j|$ , where  $j < i$ .

First, we note that an agent will never willingly reduce the number of solutions its view dominates, as per the proposal ordering and the requirements of `update_view()`. So, in the usual case,  $|W_i|$  will be monotonically increasing, for all  $i$ . However, in limited circumstances an agent may receive a weaker proposal from its support, and so the number of solutions its view dominates could be forced to decrease. Such events are rare, but they can occur whenever a cycle of supporting agents is formed. Let us assume that some agent  $v$  receives a worse proposal  $I$  from its current support, and so  $v$  is forced to choose a view which dominates less solutions. Let  $i$  number of solutions  $v$ 's old view dominates, and  $j$  be the number of solutions  $v$ 's new view dominates, respectively. The new, worse view for  $v$  will obviously decrease each  $|W_k|$ , where  $j < k \leq i$ .

However, for  $v$  to have received the worse proposal  $I$ , some agent  $w$  must have formed a cycle by changing its support. Note that  $w$  will only have selected a new support if it could increase the number of solutions its view dominates, as per the proposal ordering and the requirements of `update_view()`. Also note that the newly-formed cycle cannot have a total utility of more than  $j$ , else there would have been no reason to reduce the number of solutions  $v$ 's view dominates. Therefore, the number of solutions  $w$ 's new view dominates must then be less than or equal to  $j$ , but is certainly more than its old view.

So, if an agent  $v$  is forced to reduce the number of solutions its view dominates, then there must be some preceding agent  $w$  which increased the number of solutions its view dominates. Further,  $w$ 's new view is guaranteed to dominate no more solutions than  $v$ 's new view. Therefore, the term  $|W_1|.|W_2|.|W_3| \dots$  must increase lexicographically over time. As the term is bounded above, we can conclude that the utility of view must eventually become stable for each agent.  $\square$

**THEOREM 3.5.** *SSBDO is an instance of SDCOP with the following limitations:*

- *The domain of variables ( $\bigcup \mathcal{D}$ ) must be finite.*
- *The quality of a solution must be monotonically non-decreasing as the solution is extended, i.e.  $\forall a, b \in V, a \otimes b \preceq a$ .*

*Proof.* The elements  $\mathcal{A}, \mathcal{X}, \mathcal{D}, \mathcal{V}$  and  $\mathcal{C}$  are defined the same in SSBDO and SDCOP.

SSBDO does not support problems where the domain of a variable may be finite. This case is excluded by the first restriction on an SDCOP.

Further, the SSBDO algorithm is only sound when aggregating two semiring values does not produce a less preferred semiring value. This case is excluded by the second restriction on an SDCOP.  $\square$

**3.2. Example.** As an example of how SBDOsr works consider the following simple graph colouring problem. Note that while SDCOP requires the constraints to be encoded as functions returning semiring values, for ease of understanding we will discuss the problem in terms of hard and valued constraints. There are three agents,  $\Gamma$ ,  $\Delta$  and  $\Theta$ , each of which have write privileges for one variable,  $\gamma$ ,  $\delta$  and  $\theta$  respectively. Each variable can take one of three 'colours', 0, 1 and 2. Neighbouring variables share a valued constraint of colour difference, maximize the difference between the values assigned to each agent. Each variable also has a unary valued constraint of colour affinity, minimize the distance between its value and an ideal value. The ideal value is 0, 1 and 1 for  $\gamma$ ,  $\delta$  and  $\theta$  respectively.

When the algorithm starts each agent has received no other proposals to build upon. So all of them choose an assignment based on the colour affinity constraint.  $\Gamma$  adopts the proposal  $\langle\langle\Gamma, \{\langle\gamma, 0\rangle\}, (0, 2)\rangle\rangle, \{\}$ ,  $\Delta$  adopts the proposal  $\langle\langle\Delta, \{\langle\delta, 1\rangle\}, (0, 2)\rangle\rangle, \{\}$  and  $\Theta$  adopts the proposal  $\langle\langle\Theta, \{\langle\theta, 1\rangle\}, (0, 2)\rangle\rangle, \{\}$ . Each agent then sends their choice to each of the other agents.

Now we concentrate only on  $\Theta$ . The reasoning for the other agents is similar. None of the proposals  $\Theta$  has dominate any of the others, and each of itself,  $\Delta$  and  $\Gamma$  have supplied one non-dominated proposal, and all proposals are of length 1. As such  $\Theta$  randomly chooses  $\Gamma$  as its **support** and extends each of  $\Gamma$ 's proposals to find the following non-dominated proposals:

- $\langle\langle\Gamma, \{\langle\gamma, 0\rangle\}, (0, 2)\rangle\rangle, \langle\langle\Theta, \{\langle\theta, 2\rangle\}, (0, 0)\rangle\rangle, \{\langle\langle\gamma, \theta\rangle, (2, 0)\rangle\}$  with a utility of (2, 2)
- $\langle\langle\Gamma, \{\langle\gamma, 0\rangle\}, (0, 2)\rangle\rangle, \langle\langle\Theta, \{\langle\theta, 1\rangle\}, (0, 1)\rangle\rangle, \{\langle\langle\gamma, \theta\rangle, (1, 0)\rangle\}$  with a utility of (1, 3)

As the first proposal found is new, only the front of it,  $\langle\langle\Theta, \{\langle\theta, 2\rangle\}, (0, 0)\rangle\rangle, \{\}$ , is sent to the other agents, while the entirety of the second proposal is sent.

In  $\Theta$ 's next cycle it receives the following proposals from  $\Gamma$  and  $\Delta$ :

- $\langle\langle\Delta, \{\langle\delta, 1\rangle\}, (0, 1)\rangle\rangle, \langle\langle\Gamma, \{\langle\gamma, 0\rangle\}, (0, 2)\rangle\rangle, \{\langle\langle\gamma, \delta\rangle, (1, 0)\rangle\}$  with a utility of (1, 3)
- $\langle\langle\Theta, \{\langle\theta, 1\rangle\}, (0, 2)\rangle\rangle, \langle\langle\Delta, \{\langle\delta, 1\rangle\}, (0, 2)\rangle\rangle, \{\langle\langle\delta, \theta\rangle, (0, 0)\rangle\}$  with a utility of (0, 4)
- $\langle\langle\Delta, \{\langle\delta, 0\rangle\}, (0, 0)\rangle\rangle, \{\}$  with a utility of (0, 0), (because it is a new assignment it starts at length one)
- $\langle\langle\Delta, \{\langle\delta, 2\rangle\}, (0, 0)\rangle\rangle, \{\}$  with a utility of (0, 0)

$\Theta$  then decides to retain  $\Gamma$  as its support because the largest number of non-dominated proposals are from  $\Theta$ 's **view** ( $\Delta$  and  $\Theta$  supply one each). Next  $\Theta$  extends the proposal received from  $\Gamma$  to get:

- $\langle\langle\Delta, \{\langle\delta, 1\rangle\}, (0, 1)\rangle\rangle, \langle\langle\Gamma, \{\langle\gamma, 0\rangle\}, (0, 2)\rangle\rangle, \langle\langle\Theta, \{\langle\theta, 1\rangle\}, (0, 1)\rangle\rangle, \{\langle\langle\gamma, \delta\rangle, (1, 0)\rangle, \langle\langle\gamma, \theta\rangle, (1, 0)\rangle, \langle\langle\delta, \theta\rangle, (0, 0)\rangle\}$  with a utility of (2, 4)
- $\langle\langle\Delta, \{\langle\delta, 1\rangle\}, (0, 1)\rangle\rangle, \langle\langle\Gamma, \{\langle\gamma, 0\rangle\}, (0, 2)\rangle\rangle, \langle\langle\Theta, \{\langle\theta, 2\rangle\}, (0, 0)\rangle\rangle, \{\langle\langle\gamma, \delta\rangle, (1, 0)\rangle, \langle\langle\gamma, \theta\rangle, (2, 0)\rangle, \langle\langle\delta, \theta\rangle, (1, 0)\rangle\}$  with a utility of (4, 3)

Again  $\Theta$  then informs  $\Delta$  and  $\Gamma$  of the solutions it has chosen.

As these two proposals represent the optimal solutions for this problem execution continues for one more cycle, as  $\Delta$  and  $\Gamma$  accept them as the optimal solutions.

**4. Results.** We ran a set of experiments to evaluate SBDOsr. To do so, we implemented SBDOsr in C++<sup>2</sup> and ran tests on a set of graph colouring problems. The tests were run on an Intel Xeon X3450 CPU with 8GB of RAM.

At this time, there is only one other published algorithm that is capable of solving problems with many objective functions, B-MUMS [7]. We do not compare SBDOsr with B-MUMS as B-MUMS does not support hard constraints, as are used in our experiments, and B-MUMS only returns one solution<sup>3</sup>.

In our test problem, there is a one to one mapping from agents to variables and each variable can take a value from the domain  $\{0, 1, 2, 3, 4\}$ . Each variable is identified by a unique integer. There are three constraints between each pair of neighbouring variables. The first is a hard constraint that neighbouring variables must not have the same value. The second is a valued constraint to maximize the distance between the two values, given that the values wrap around i.e. the distance between 0 and 4 is 1. The third is a valued constraint where the variable with the higher identifier should be assigned a larger value. Finally, every variable has a unary valued constraint to minimize the distance between the variables value and an ideal value, being the variables identifier modulo 5.

For our tests, we varied the number of variables in each problem and the number of constraints. The parameter for the graph connectedness varies linearly between 0, where the constraints form a spanning tree over the variables, and 1, which is a fully connected graph. We used a number of variables from the set  $\{4, 5, 6, 7, 8, 9, 10, 15, 20, 25\}$ , a number of constraints from the set  $\{0.0, 0.1, 0.2, 0.3, 0.4\}$ , and randomly generated five problems for each pair of parameters. Each problem was solved five times and the performance averaged to give the results presented here. Individual runs were terminated after half an hour of wall clock time.

We present the performance of SBDOsr based on five metrics, and the standard deviation for each metric:

1. (Terminate) Time for the algorithm to terminate.

<sup>2</sup>Source code available from <http://www.geeksinthegong.net/svn/sbdo/trunk/>.

<sup>3</sup>We acknowledge that B-MUMS could easily be modified to return many solutions, as it finds them during processing.

Table 4.1: Performance of SBDOsr. See text for description of metrics.

variables	Terminate (s)	Aggregate (s)	number of solutions	solution quality	Proportion
4	0.15 (0.13)	0.01 (0.00)	9.66 (5.20)	0.13 (0.13)	0.46 (0.26)
5	0.20 (0.12)	0.01 (0.01)	11.38 (6.33)	0.22 (0.32)	0.49 (0.26)
6	0.35 (0.33)	0.02 (0.01)	13.58 (6.11)	0.25 (0.29)	0.52 (0.24)
7	0.76 (0.83)	0.04 (0.04)	17.54 (10.18)	0.23 (0.27)	0.47 (0.24)
8	1.87 (3.24)	0.05 (0.04)	21.87 (14.65)	0.35 (0.34)	0.38 (0.24)
9	3.68 (5.54)	0.15 (0.24)	31.63 (24.70)	0.38 (0.33)	0.35 (0.24)
10	6.02 (8.33)	0.16 (0.20)	30.27 (17.72)	0.50 (0.33)	0.25 (0.21)
15	125.10 (233.45)	5.43 (20.17)	52.47 (66.61)	-	-
20	287.72 (259.97)	64.67 (184.73)	76.44 (189.77)	-	-
25	433.88 (548.73)	269.87 (546.00)	50.00 (158.81)	-	-

2. (Aggregate) Time to aggregate the partial solutions.
3. (number of solutions) Total number of solutions found.
4. (solution quality) The average of the minimum euclidean distance from the utility of each non-optimal solution to the utility of an optimal solution. Formally:

$$\text{quality} = \frac{\sum_{n \in N} \min(f(n, o_1), \dots, f(n, o_x))}{|N|}$$

where  $f(x, y)$  is the euclidean distance between  $x$  and  $y$ ,  $S$  is the set of the utilities of the solutions found by SBDOsr,  $O$  is the set of utilities of the optimal solutions and  $N = S/O$ .

5. (Proportion) The proportion of optimal solutions found. Formally:

$$\text{proportion} = \frac{|O \cap S|}{|O|}$$

Note that the set of optimal solutions must be known to compute metrics four and five. We used exhaustive search to find all the optimal solutions for problems with up to ten variables, it proved to be infeasible to solve bigger problems using exhaustive search.

Because each agent only has a local view of the problem a post-processing step is required to combine all the partial solutions into complete solutions. Whether this step is required depends on the problem being solved, decision support applications will require complete solutions, but some things like autonomous robots may be able to function using only local knowledge. It also depends on how many solutions are desired, for these experiments we extracted all pareto-optimal solutions found by SBDOsr. Because of this, we have presented the time required for the algorithm to terminate and the time to aggregate the partial solutions into global solutions separately.

The performance of SBDOsr is shown in Table 1. The number of constraints in the problem had very little effect on the performance, so we have not reported those results here. As expected, the number of variables in the problem has a large impact on the performance. Both the time required for the algorithm to terminate and the number of solutions found when the algorithm does terminate increases exponentially as the number of variables increases. Furthermore, the time required to aggregate all solutions is dependant on the number of solutions, so aggregation time also rises exponentially as the number of solutions increases.

The standard deviations show that the performance of SBDOsr is highly unstable, often the standard deviation is greater than the mean. This is due to the highly non-deterministic nature of the SBDOsr algorithm. The order in which agents perform actions introduces a search bias. This bias determines which solutions are found and how much effort is required to terminate.

The proportion of optimal solutions that SBDOsr finds drops off as the number of variables increases. While the average distance from each non-optimal, found solution to an optimal solution remains constant, representing a change to the assignment to one variable by about one unit. This shows that while the number of

points discovered on the actual pareto-front drops off as the number of variables increases, the solutions found remain close to the actual pareto-front.

In the process of solving these problems, SBDOsr generates a large number of nogoods. As our implementation of SBDOsr only has relatively simple code for searching and checking nogoods, this represents a significant performance bottleneck and contributes to the time required for the larger problems.

**5. Conclusion.** We have presented a modification of SBDO to support problems with multiple objectives, or in general, any DCOP problem where there does not exist a total pre-order over the set of solutions. In order to represent these problems, we propose a new definition of a DCOP using an idempotent semiring to measure the cost/utility of a solution. The SBDO algorithm was then modified to use this new definition. To solve problems of this form, each agent maintains multiple candidate solutions simultaneously. The partial solutions maintained by each agent can then be combined into a set of complete solutions.

Empirical evaluation shows that the algorithm finds a good approximation of the pareto-frontier, however the post-processing step to combine each agent's partial solutions into complete solutions requires significant computational effort, and is currently done centrally. While this is a weakness of this approach, in situations such as autonomous robot control where complete solutions are not required for the agents to act, such a weakness is acceptable.

#### REFERENCES

- [1] U. BERTELE AND F. BRIOSCHI, *Nonserial Dynamic Programming*, Academic Press, 1972.
- [2] G. BILLIAU, C. F. CHANG, AND A. GHOSE, *SBDO: A New Robust Approach to Dynamic Distributed Constraint Optimisation*, in *Principles and Practice of Multi-Agent Systems*, 2010.
- [3] S. BISTARELLI, U. MONTANARI, AND F. ROSSI, *Semiring-based constraint satisfaction and optimization*, J. ACM, 44 (1997), pp. 201–236.
- [4] K. M. CHANDY AND L. LAMPORT, *Distributed Snapshots: Determining global states of distributed systems*, ACM Transactions on Computer Systems, 3 (1985), pp. 63–75.
- [5] R. DECHTER, *Bucket elimination: A unifying framework for reasoning*, in *Artificial Intelligence*, vol. 113, 1999, pp. 41–85.
- [6] R. DECHTER AND I. RISH, *Mini-buckets: A general scheme for bounded inference*, in *Journal of the ACM*, vol. 50, Mar 2003, pp. 107–153.
- [7] F. M. D. FAVE, R. STRANDERS, A. ROGERS, AND N. R. JENNINGS, *Bounded Decentralised Coordination over Multiple Objectives*, in *AAMAS*, 2011, pp. 371–378.
- [8] T. GRINSHPOUN, A. GRUBSHEIN, R. ZIVAN, A. NETZER, AND A. MEISELS, *Asymmetric distributed constraint optimization problems*, J. Artif. Intell. Res. (JAIR), 47 (2013), pp. 613–647.
- [9] P. HARVEY, *Solving Very Large Distributed Constraint Satisfaction Problems*, PhD thesis, University of Wollongong, 2010.
- [10] P. HARVEY, C. F. CHANG, AND A. GHOSE, *Support-based distributed search: a new approach for multiagent constraint processing*, in *AAMAS '06*, ACM, 2006, pp. 377–383.
- [11] J. LARROSA, *On arc and node consistency in weighted CSP*, in *proc. of AAAI'02*, 2002, pp. 48–53.
- [12] P. J. MODI, W.-M. SHEN, M. TAMBE, AND M. YOKOO, *ADOPT: asynchronous distributed constraint optimization with quality guarantees*, *Artificial Intelligence*, 161 (2005), pp. 149–180.
- [13] J. P. PEARCE AND M. TAMBE, *Quality Guarantees on k-Optimal Solutions for Distributed Constraint Optimization Problems*, in *IJCAI*, M. M. Veloso, ed., 2007, pp. 1446–1451.
- [14] A. PETCU, *A class of algorithms for Distributed Constraint Optimisation*, PhD thesis, École Polytechnique Fédérale de Lausanne, Oct 2007.
- [15] A. PETCU AND B. FALTINGS, *DPOP: A Scalable Method for Multiagent Constraint Optimization*, in *IJCAI 05*, Aug 2005, pp. 266–271.
- [16] E. ROLLON, *Multi-objective Optimization in Graphical Models*, PhD thesis, Universitat Politècnica de Catalunya, 2008.
- [17] A. ROSENFELD, *An Introduction to Algebraic Structures*, Holden-Day, 1968.
- [18] F. ROSSI, P. VAN BEEK, AND T. WALSH, eds., *Handbook of Constraint Programming*, Elsevier, 2006.
- [19] T. SCHIEX AND G. VERFAILLIE, *Nogood Recording for Static and Dynamic Constraint Satisfaction Problem*, *International Journal of Artificial Intelligence Tools*, 3 (1994), pp. 187–207.
- [20] M. C. SILAGHI AND M. YOKOO, *Nogood based asynchronous distributed optimization (ADOPT-ng)*, in *AAMAS '06*, ACM, 2006, pp. 1389–1396.

*Edited by:* Yang Xu

*Received:* April 15, 2015

*Accepted:* January 14, 2016







## SCALING BEYOND ONE RACK AND SIZING OF HADOOP PLATFORM

WIESŁAWA LITKE\* AND MARCIN BUDKA†

**Abstract.** This paper focuses on two aspects of configuration choices of the Hadoop platform. Firstly we are looking to establish performance implications of expanding an existing Hadoop cluster beyond a single rack. In the second part of the testing we are focusing on performance differences when deploying clusters of different sizes. The study also examines constraints of the disk latency found on the test cluster during our experiments and discusses their impact on the overall performance. All testing approaches described in this work offer an insight into understanding of Hadoop environment for the companies looking to either expand their existing Big Data analytics platform or implement it for the first time.

**Key words:** Hadoop, Big Data analytics, scalability, benchmarking, teragen, terasort, teravalidate, inodes, platform bottlenecks, disk latency

**AMS subject classifications.** 11Y35, 20B40, 68, 68U, 93B40

**1. Introduction.** Hadoop is a distributed computational environment designed to facilitate storage and analysis of large heterogeneous datasets (Big Data), which typically grow at high velocity [14]. It is a very sought after technology platform that many companies have either already deployed, are currently deploying or are looking to investing into. According to [15] the market penetration of Hadoop reached 32% among all enterprises at the end of 2014 and is predicted to grow to as much as 66% within the next two years.

One of the key components of the platform is the Hadoop Distributed File System (HDFS). Its roots stem from a simple problem: the transfer speeds of hard drives have not kept up with growing storage capacity. In 1990 a typical drive could store 1,370MB of data which could be accessed at 4.4 MB/s [14], so the contents of that drive could be read in just over five minutes. Two decades later, 1TB drives are the norm with access speeds of around 100MB/s taking almost 3 hours to read, which is an unacceptable bottleneck in the datacentre world, where the size of a typical dataset is measured in petabytes. Hadoop overcomes this limitation by simultaneously reading from multiple drives. 100 drives sharing an equal share of 1TB of data could be read in less than two minutes. This comes with a trade-off: higher risk of drive failure. Again this shortcoming is mitigated through storing multiple copies of files (replication). Analytics in this setting is facilitated by the MapReduce programming model which enables processing of large datasets via efficient parallelisation techniques [3], handling both structured and unstructured data that is complex, large and rapidly growing.

A typical architecture of a Hadoop cluster consists of a number of racks populated with commodity servers, referred to as nodes (cf. Fig. 1.1). Majority of those servers will be slave nodes (or data nodes) with a single master node (or management server), responsible for overseeing the key functionality of services such as HDFS or MapReduce [5]. The data nodes are normally populated with a moderate capacity of memory and storage (for details please refer to Sect. 2). Connectivity is provided via a high-throughput switch and bonded network links.

Planning deployment of a Hadoop cluster involves consideration of hardware type, software choices, size (i.e. number of nodes) and anticipated load of the platform. If a business is looking to invest into Big Data analytics they face the problem of how considerable the investment should be, to deliver required storage and computational capacity to handle their workload. Future expansion also needs to be considered.

In this study we look into the scalability issues of the Hadoop platform and its impact on performance defined as time required to complete any given task. Two test scenarios have been devised:

1. Implications of scaling out a single-rack solution to a second rack. This scenario is applicable to businesses that already have an in-house Hadoop installation, however they need to expand. In this study we investigate expected performance improvements.
2. Performance of processing a workload as a function of the number of nodes at varying loads. This part of the study aims to aid the organisations with decision of size of the cluster that they want/need to

\*Intel Corporation, Pipers Way, Swindon Wiltshire SN3 1RJ, United Kingdom, [wieslawa.litke@intel.com](mailto:wieslawa.litke@intel.com)

†Faculty of Science and Technology, Bournemouth University, Fern Barrow, Talbot Campus, Poole, Dorset, BH12 5BB, United Kingdom, [mbudka@bournemouth.ac.uk](mailto:mbudka@bournemouth.ac.uk)

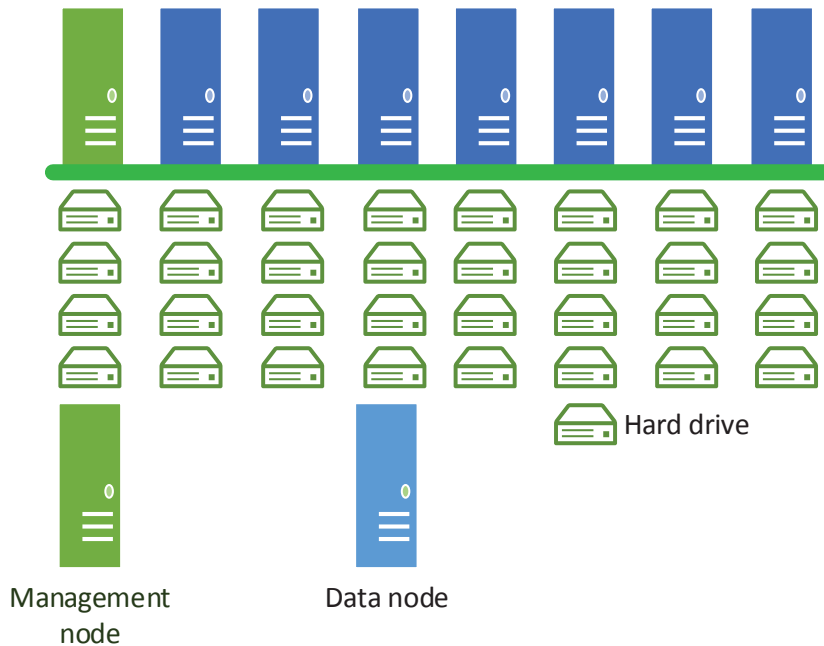

Fig. 1.1: Cluster schematic diagram

implement.

The remainder of this paper is structured as follows. Sect. 2 briefly reviews related work. In Sect. 3 we outline the configuration of a cluster that was used to perform the experiments. The subsequent section describes in detail the chosen benchmark suite (TeraSort). The benchmark results and the performance of the cluster are reported in Sect. 5, while Sect. 6 contains analysis and discussion of the results. Finally, conclusions and outline of plans for future work can be found in Sect. 7.

**2. Related work.** When planning implementation of Hadoop cluster(s) the deployment model is one of the most important decisions to make. Keeping Return of Investment (ROI) in mind the decision makers must choose whether to deploy on-premise hardware (bare metal), fully deploy in the Cloud or opt for something in between. Each of those options carries its own challenges and concerns. Five main deployment models are distinguished in [13]:

- On-premise full custom (bare metal) with Hadoop installed directly on companys hardware and the business holding full control of data and cluster management.
- Hadoop appliance, which allows the business to jumpstart the data analysis process on a preconfigured cluster owned by a third party operator.
- Hadoop hosting, where the service provider takes care of both cluster configuration and operation on behalf of the client.
- Hadoop on the Cloud, which allows the business to create Hadoop environment on virtual machines while maintaining full control as in bare metal.
- Hadoop-as-a-Service, in which the business is charged on pay-per-use basis.

**2.1. Scaling beyond 1 rack.** In [10] the author describes scalability as one of the most important attributes organisations are looking for in the Hadoop architecture. He recognises Hadoop environment deployed on commodity hardware as the most common model of deployment which provides incremental scalability

capabilities ideal for inevitable expansions of the platform.

Many analytic workloads require large memory resources to enable efficient search, read and write job execution. Unsurprisingly, I/O intensive in-memory operations outperform the ones that require hard drive access. However due to hardware constraints any commodity server would be limited in the available memory for analytic jobs processing. This is where the expansion of the cluster comes in. By adding additional racks an organisation can add extra pools of memory. However, that entails spreading the workload over multiple parallel servers, which can increase accompanying job coordination overheads.

When all those conditions are met and an organisation has installed new nodes as part of the cluster it is likely that the expanded cluster has become unbalanced [4]. Although new hardware is added to the platform, linked to the management server, and seen and recognised by the existing nodes, the data will stay where it is unless instructed otherwise. Job Tracker is a service that controls and assigns MapReduce jobs on the cluster. In order to avoid data shuffling between racks it will always assign jobs to run locally where the files are stored, if possible. This means that the MapReduce tasks are not going to be assigned to the new nodes unless the old nodes are at their maximum capacity. This results in underutilisation of the new resources.

Currently there are two trends for expanding the resources of the Hadoop cluster: scale out and scale up. The scale up option is based on adding additional storage devices to the existing rack and although it is the economical choice the cluster will rely on the same amount of management capabilities as before which may cause bandwidth issue. The scale out alternative adds both storage and performance to the existing environment which is what this paper focuses on. In [12] Sevilla presents a point where scaling up of the cluster affects its parallelism due to bottlenecks. In various tests he illustrates how scale up clusters work in sequential job phases and are outperformed by scale out clusters on which the jobs are parallelised. His point is being argued by Appuswamy [2] where he illustrates how to improve the performance of scale up by series of optimisations.

**2.2. Scalability of nodes processing the workload.** In [7] the author has surveyed 202 IT professionals from organisations that were either already deploying Hadoop or considering to do so. According to the results, the most common initial size of Hadoop clusters fall between 11 and 60 nodes. Smaller and larger deployments are a minority.

The same companies have also been asked about the storage infrastructure growth within the cluster in order to establish the general prospective need to expand the initial deployment. The most common answer among the participants was 20-29%, however a sizable amount of respondents was seeing growth of as much as 50%. This leads to the conclusion that flexibility and scalable architecture of cluster and storage needs to be accounted for in the planning of a Hadoop environment.

Some ideas on how to make an educated judgment with respect to the size of initial Hadoop deployment are given in [11]. The most commonly used method involves estimating the storage capacity required to process the data currently held. The planner should allow for future growth of the data, taking into account that management of the organisation may not be willing to invest into expansion immediately, at least until data analytics provide tangible benefits to the business. Two common estimates are flat growth of 5% or 10% per month. Over time, upgrading a running cluster becomes necessary, usually driven by the data ingest rates, which means that as more data comes into the system more nodes need to be added, providing not only storage but also computational resources.

The second, less common way of assessing the required start-up size of the cluster is the time to complete specific jobs. It is a rather complicated process where factors such as CPU resources, available memory, disk I/O latency have to be taken into consideration and complex calculations need to be performed to give an informed judgment on the required size of the cluster to complete MapReduce jobs within an expected timeframe.

**3. Platform architecture and system configuration.** For the purpose of this study a 16 node Hadoop cluster has been commissioned. The cluster consists of 16 servers installed in a single physical rack that are running a Cloudera Deployment of Apache Hadoop (CDH) managed by a single Management server (IMS). All the nodes are 1U chassis form factor, two socket Wildcat pass servers. Each data node is populated with 12 HDDs with a total capacity between 10.5 and 11.4 TB per node. One of the nodes is serving as Name Node which keeps the record of the file location of all the files and their replicas. The master node has 4.7 TB of storage. Every node is running two Intel Xeon E5-2697 v3 processors. Five nodes (out of 16) and IMS are

populated with 252.2 GB of RAM. The remaining nodes use 125.9 GB of memory. Connectivity is provided by the 40 GbE.

The cluster is linked to an automated OS/configuration provisioning system. It is a mechanism that allows automatic deployment, monitoring, updating and management of all the nodes. It has been used to deploy the OS<sup>1</sup>.

In order to deploy Hadoop 2.0, Cloudera Manager version 5.3.3 has been utilised. Cloudera Manager is a piece of software that simplifies and shortens the process of Hadoop installation and configuration. The built-in monitoring utilities have been used to collect data for this study.

**4. TeraSort benchmark.** Careful consideration has been put into the choice of benchmarks used to validate the outcomes of this study. Ultimately the TeraSort benchmark suite has been chosen as a single point of reference. TeraSort is a set of benchmarks very widely known and used in the Hadoop world [9]. Its purpose is to test the CPU power of the cluster. The benchmark conveniently has data generation utilities as well as sorting functionality. It consists of three stages: *teragen*, *terasort* and *teravalidate*. The benchmarking procedure starts with *teragen* which generates a data set of size specified as the number of rows to be created during the run. *Terasort* uses Map and Reduce functions to sort the generated dataset, which is then read and validated by *teravalidate*.

For the purpose of this study two *teragen* sizes have been used: 10 bln (bln=billion) and 20 bln rows, in order to accommodate benchmarking scalability.

Before the benchmark is run, the script performs a pre-run clean-up of the root directories to guarantee a clean run every time. Without that step the directories could be filled with data from previous benchmark runs and compromise the consistency of testing as the preconditions of the cluster would be different to the previous step. In cases where a number of nodes had to be decommissioned (part 2 of testing) some manual cleaning of directories was required.

After the clean-up is complete, the following sequence of tests is run three times:

1. *Teragen* - 10 bln,
2. *Terasort* - 10 bln,
3. *Teravalidate* - 10 bln,
4. *Teragen* - 20 bln,
5. *Terasort* - 20 bln,
6. *Teravalidate* - 20 bln,

producing a total of 18 test results per script run.

The benchmark metrics can then be retrieved from Cloudera Manager (Yarn >Applications). Two main metrics have been recorded:

1. Time to complete, which marks the duration of the run for every benchmark, as the most meaningful indication of the cluster performance.
2. CPU time, which is the total time the processor has spent executing instructions during the run and is usually expressed in higher time units e.g hours (h) or days (d). On multi-processor machines like the ones in this study, where each CPU holds multiple cores, the total CPU time is calculated by summing up the CPU time for all processors and their cores. This metric gives an indication of the energy efficiency of a particular processing scenario.

The results for each run are collected and an average for every test from all three runs is taken, with a provision that any deviation larger than 20% will call for a full retest, which is a protocol accepted at the company that has provided the facilities for this study.

Also to validate the acceptable range of results a 99% confidence interval for mean has been calculated [1], giving an indication of a tolerable margin of error in the results based on the sample size, observed mean and standard deviation.

---

<sup>1</sup>For confidentiality reasons the name of the OS vendor has been withheld. List of OSs compatible with Cloudera can be found at: [www.cloudera.com/content/cloudera/en/documentation/cdh4/latest/CDH4-Requirements-and-Supported-Versions/cdh4sv\\_topic\\_1.html](http://www.cloudera.com/content/cloudera/en/documentation/cdh4/latest/CDH4-Requirements-and-Supported-Versions/cdh4sv_topic_1.html)

## 5. Results.

**5.1. Scaling beyond 1 rack.** In the first part of the benchmarking process three tests have been performed (cf. Table 5.1). The mean of the three runs in all three tests have been used to examine the implications of scaling out Hadoop beyond one rack.

Table 5.1: Scaling beyond one rack tests specification

Test no	# of nodes	Notes	Label
1	16	deployed in 1 rack	16-node-A
2	16	deployed in 2 logical racks, 8 nodes each	16-node-B
3	8	deployed in 1 rack	8-node

Fig. 5.1(a) summarises the time to complete for tests *16-node-A*, *16-node-B* and *8-node*. As it can be seen the differences between *16-node-A* and *16-node-B* are marginal. A single rack with all 16 nodes performed slightly better when generating and handling 10 bln rows. As expected, the difference between the first two and the third benchmark consisting of only 8 nodes is considerable - the benchmark took more than 2 times longer to complete in the latter case.

There is no surprise in that difference as the number of nodes has been halved. In case of *teragen* and *terasort* the time to complete grew by 102% and 144% respectively. The *teravalidate* time however has surprisingly increased by as much as 265% relative to *16-node-B* test results.

The results from generating 20 bln rows prove to differ from the 10 bln row scenario. As it can be seen in Fig. 5.1(a) the results from *16-node-A* and *16-node-B* appear to be very similar. While in test *16-node-A* the time to complete on *teragen* is considerably lower than test *16-node-B*, in the case of *terasort* and *teravalidate* it's only marginally shorter.

Similarly to 10 bln row benchmarking the differences in results on 20 bln rows between tests *16-node-A* and *16-node-B* remain very small. In fact, they are small enough to say that they fall within the margin of error (cf. Fig. 5.1(b)). A *t-test*, which according to [1], T-test takes into account all the three results from the benchmarking and can judge whether the difference between the two data sets is statistically significant. The test compared the result of all three runs between both tests A and B revealed, that in the case of *terasort* and *teravalidate* the differences in results are not statistically significant .

Results from the 8-node test show that the cluster has taken 106%, 138% and 347% longer to complete *teragen*, *terasort* and *teravalidate* respectively.

The CPU time metric does not show major changes between the benchmarks results. For both the 10 and 20 bln scenario, the results are very close to each other as depicted in Figs. 5.1(c) and 5.1(d).

**5.2. Scalability of Hadoop cluster.** The second part of testing constitutes of a series of tests that aim to evaluate performance difference when choosing to deploy clusters of varying sizes. The specification of the test has been given in Table 5.2.

Table 5.2: Scalability of Hadoop cluster tests specification<sup>2</sup>

Test no	# of nodes	Label
1	16	16-node test
4	14	14-node test
5	12	12-node test
6	10	10-node test
3	8	8-node test

<sup>2</sup>The results from test 1 and 3 have been reused as the their specifications matched the required testing. The test numbering in first column is dictated by the number of nodes in the tested cluster.

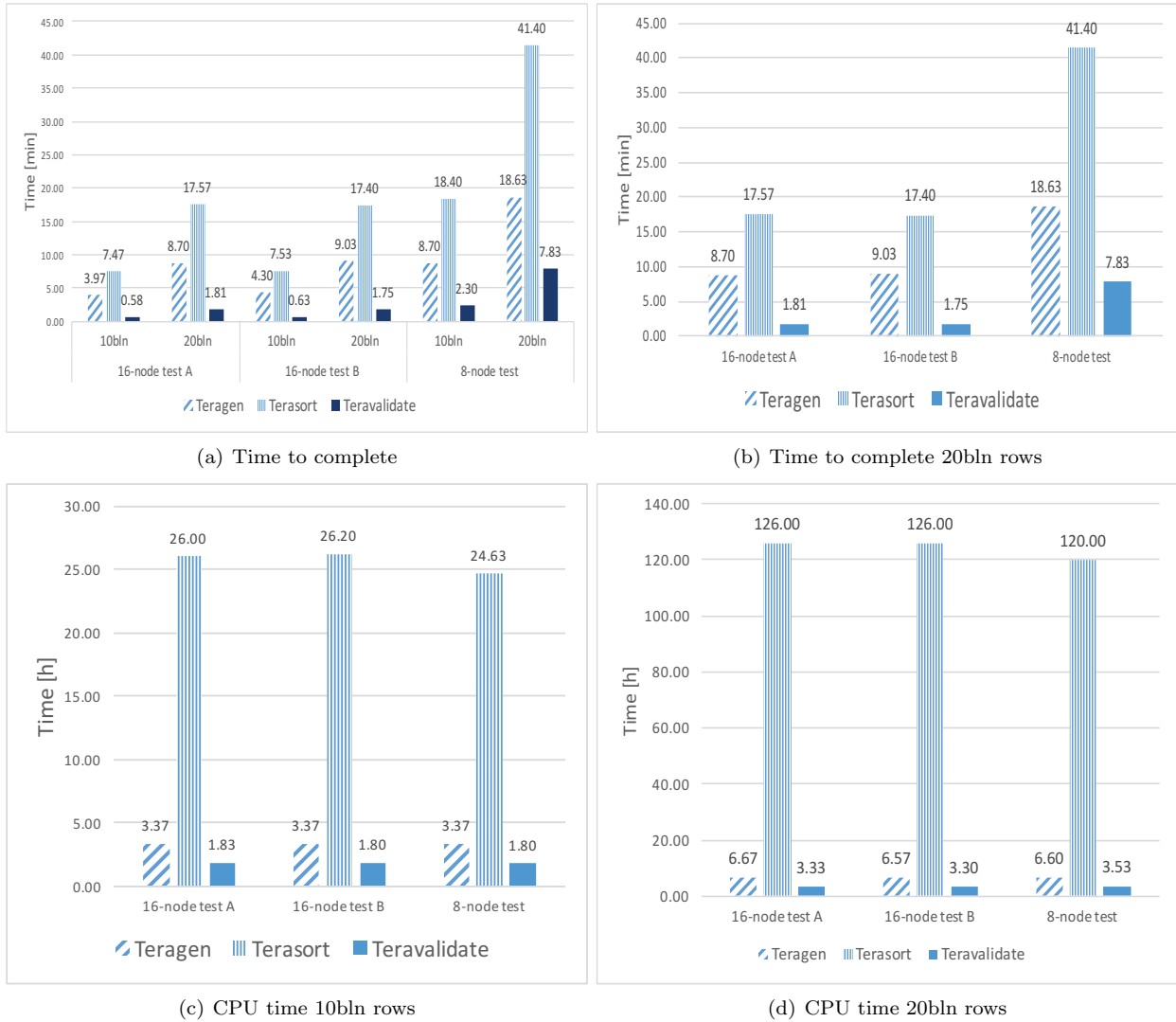

Fig. 5.1: Time to complete and CPU time for 16-node test A, 16-node test B and 8-node test

Similarly to test described in Sect. 5.1, the average of all three benchmarks for every result was taken as the most reliable value. As it can be seen in Fig. 5.2(a), which summaries the time to complete results for all five tests on both 10 and 20 bln rows, the scaling rises at half parabolic manner. The time to complete the benchmarks gradually rises for both *teragen* sizes as more and more nodes are taken away from the cluster.

A simplified graph with the results only for 10 bln rows *teragen* size (cf. Fig. 5.2(b)) shows more clearly how the results grow steadily but not linearly. The growth in case of *teragen* has progressed with a 17% rise for 14-node test, 37% for 12-node test, 70% for 10-node test and 119% for 8-node test from the initial value in test 1. Similar values were recorded for *terasort*: 13%, 37%, 78% and 146% respectively. In case of *teravalidate* the 14-node test and 12-node test have taken only 12% and 19% longer to complete than 16-node test. The remaining two tests however have taken 102% (10-node test) and 293% (8-node test) more time to run the benchmark.

The half parabolic growth tendency is also visible for the 20 bln rows generation and processing (cf. Fig. 5.2(c)). The *teragen* and *terasort* maintain very similar growth percentage wise in time to complete

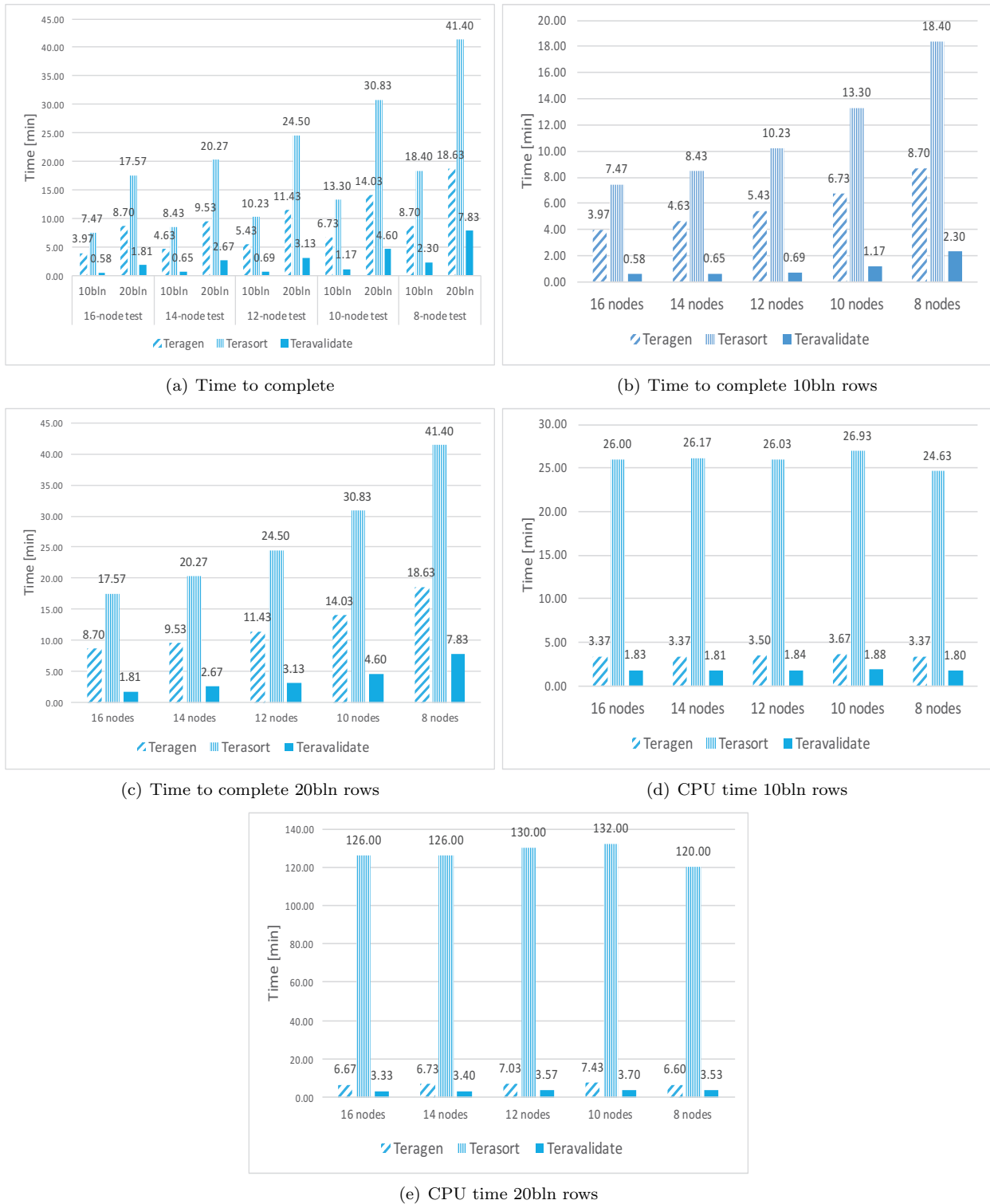

Fig. 5.2: Time to complete and CPU time for 16, 14, 12, 10 and 8 nodes

compared to the results of 10 bln tests. The changes in the *teravalidate* benchmark are more dramatic with 48% growth in 14-node test, 72% in 12-node test, 154% in 10-node test and 333% in 8-node test compared to 16-node test.

Similarly to the experiments of Sect. 5.2 the CPU time did not exhibit major fluctuations (cf. Figs. 5.2(d) and 5.2(e)).

During the tests we have also observed that the cluster CPU utilisation<sup>3</sup> was gradually dropping as the subsequent nodes were taken away to process the workload. In the 16-node test peaks were fluctuating around the 55% mark, with a maximum of 56.57% as shown in Fig. 5.3(a).

In the 14-node test, with just two nodes less that number came down to about 45% with a peak at 46.82% (cf. Fig. 5.3(b)).

The cluster with another 2 nodes removed in 12-node test (cf. Fig. 5.3(c)) brought down the CPU utilisation to about 40% (peak at 40.78%).

In test 6 with 10 nodes the cluster CPU utilisation drops to about 30% reaching up to 32.61% at its highest (cf. Fig. 5.3(d)).

In the 8 node test (cf. Fig. 5.3(e)) the CPU utilisation stays just above 20% with peak utilisation of 23.25%.

Throughout the testing we have kept a close eye on the Disk Latency of the drives on the utilised cluster. Disk latency constitutes the amount of time that the hard drive takes to write a chunk of data. It has transpired that there are some serious constraints on the existing system. The lower the number of nodes processing the workload, the higher the latency of the drives. In 16-node test the nodes were scoring a latency of up to 3.4 seconds which is still a relatively high waiting time. However, as the tests progressed the bottleneck of drive latency was becoming more apparent. The latency in 14-node test reached 12 seconds at its highest, in 12-node and 10-node tests - about 18 seconds and as much as 57 seconds in the last test on 8 nodes (cf. Fig. 5.3).

## 6. Analysis and discussion.

**6.1. Scaling beyond one rack.** Running the *terasort* benchmark on the cluster has shown that there is no major difference between the results on a single cluster deploying 16 nodes and two clusters with 8 nodes each. While it would be intuitive to assume that it would consume some overhead to communicate between the racks, it appears that if properly installed and configured the split racks do not make a large difference.

In the case of this study, the first stage of benchmarking - *teragen* - generates the data on both clusters simultaneously and it is distributed evenly. This is due to the design of Job Tracker, which is a built-in service in Hadoop that oversees and manages the MapReduce jobs on the platform. It consults the Name Node to find out which Data nodes hold the necessary files to process a task. Job Tracker will always attempt to fetch the data from a local node from the same rack. Only when that is not possible the Name Node will refer it outside of the rack, reducing the overheads as a result.

A situation where this might prove not to be true is a cluster that is not balanced. ‘Balanced cluster’ is a term describing a situation where the data is evenly distributed across all nodes in all the racks. In a situation where a company has a successfully running cluster to which they add an additional rack in order to expand their Hadoop platform, they end up unbalancing the system. The data stays on the old rack and the new one remains empty. This often results in underutilisation of HDFS as the MapReduce tasks are not going to be scheduled on the added nodes unless the pre-existing racks are too busy to take new jobs. Also, the platform will experience larger network bandwidth consumption and slower job completions. In cases where the new nodes are assigned MapReduce tasks that they do not have data to complete, the files will have to be carried across the network, ultimately negatively impacting the performance.

In case of the two racks used for our testing, all the data has been generated on both racks evenly and we know that the cluster is balanced. The test results have proven that a Hadoop cluster if correctly designed does not lose on the performance when configured into more than one rack.

The testing also revealed that if we halved the amount of nodes processing the workload, the time to complete have increased by more than 100% on all three benchmarks while running both *teragen* sizes. Intuitively, the performance drop should stay just short of 100% as we are reducing the amount of nodes by half and there should be some loss of performance due to overheads for split rack.

---

<sup>3</sup>Overall utilization of all CPUs in the whole cluster



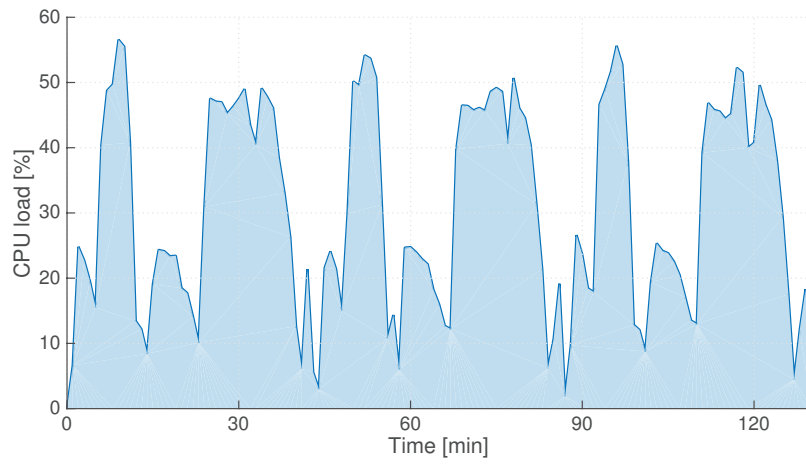

(a) 16-node test

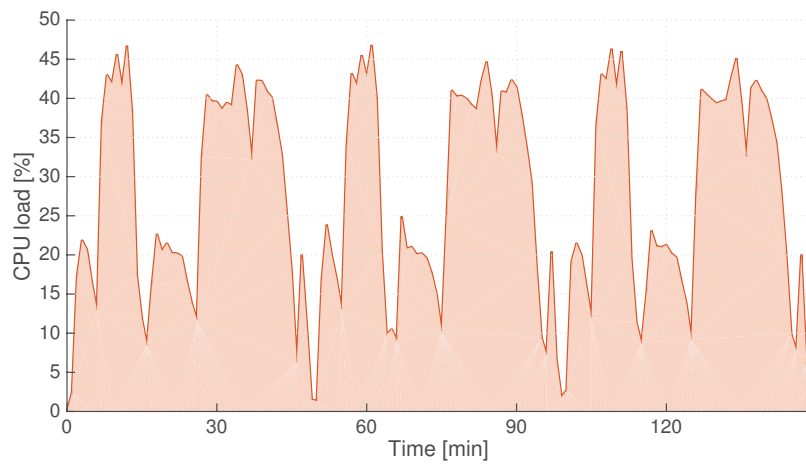

(b) 14-node test

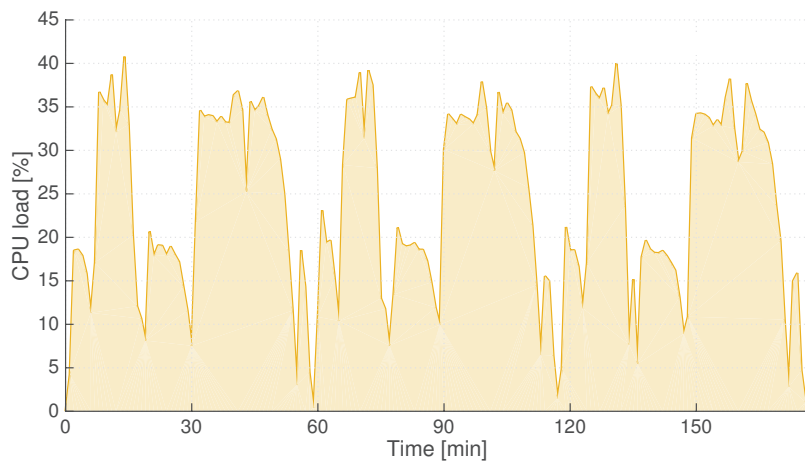

(c) 12-node test

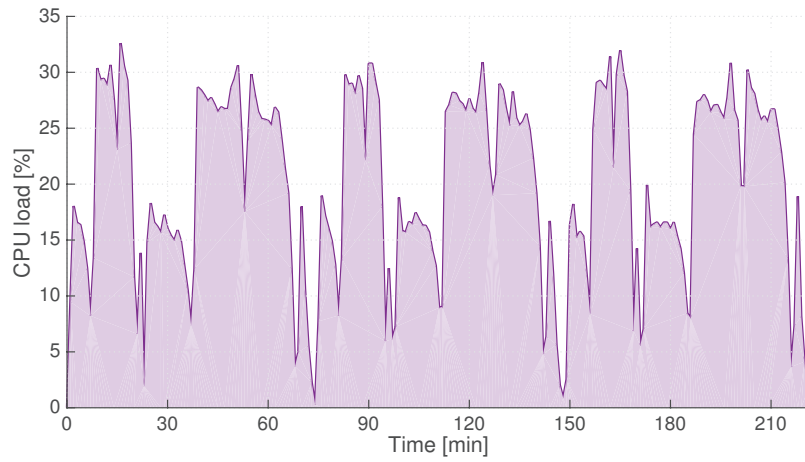

(d) 10-node test

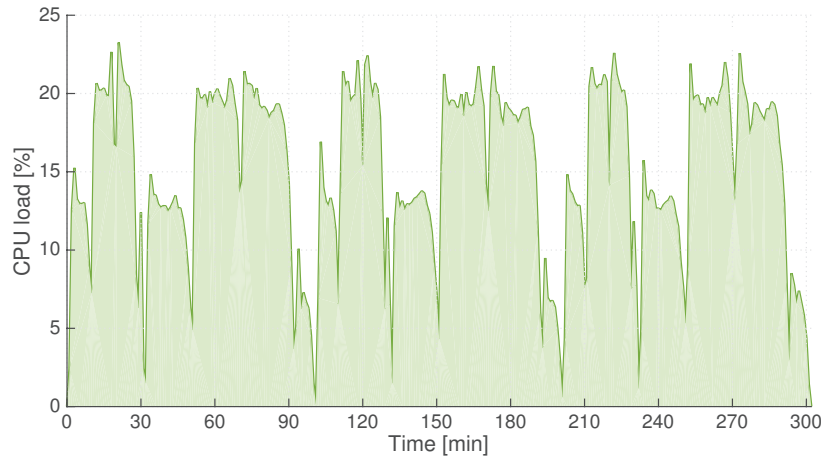

(e) 8-node test

Fig. 5.3: Cluster CPU utilisation

The marginal difference in the results between tests *16-node-A* and *16-node-B* have proven that the overheads on a split rack are practically non-existent and the communication between the racks has a very minimal impact on the performance. That however does not explain the over 100% increase in time to complete.

The explanation of the drastic performance difference lies with the *inodes* (or index nodes). *Inode* in a Unix-style files system is a data structure that keeps the contents of the file separate from the information stored about the file. So for every file on the system there is a corresponding *inode* with a unique *inode* number [8].

Running close to the limit of *inodes* explains the excessive time to complete not only on the smaller cluster in 8-node test but also explains why duration of benchmarks more than doubles for 10 bln rows and 20 bln rows. The amount of *inodes* and the space reserved for them is set during the creation of the file system. If there are a lot of small files created on the disk, like in our case during testing, the system starts to run out of *inodes* and drastically slows down long before it runs out of storage. This unfortunately cannot be changed dynamically without re-formatting the drives. If the drives run out of *inodes*, no more files can be created on the drives. This is why it is critical to accommodate for enough *inodes* to successfully complete the workload analysis.

**6.2. Scalability of Hadoop cluster.** During the benchmarking of the Hadoop cluster we have observed a gradual rise in time to complete on all three elements of the *terasort* benchmark. As the amount of nodes drops, the time the platform requires to complete the process rises in a regular and predictable manner.

Also the analysis of the Cluster CPU activity clearly tells us that the smaller the node count the less the processor capacity is utilised. With the highest number of nodes in our test - 16 - we only managed to use just over half of the cluster CPU potential. By halving the amount of nodes we are only using as little as 20% of total capacity. The 150% increase in utilization in case of 16 node cluster compared to 8 is dictated by the increased seek time on hard drives. Because the benchmarks are taking longer to complete, the stress on CPU is decreases as shown on figure 5.3, ultimately leading to underutilisation.

That activity very closely links to the Disk Latency already mentioned in Sect. 5.2, a hard drive consists of moving mechanical parts, some of the more important ones include platter, where the data is written, spindle that spins the platter, heads which write and read the data to/from the platter and is attached to the arm that moves the head to the right spot on the platter. *Inodes* can be treated as logical cells that have a space assigned on the platter. Those spaces are allocated during hard drive formatting and cannot be altered. As the head writes the data to the platter, the *inodes* become assigned to each file on the drive. When there is a large amount of small files created on the drive the *inodes* run out and the system cannot save any more data. As the drive exhausts the *inodes* available, the seek time to write the data is extending. It takes more and more time to find a free *inode* and only then a file can be assigned to it (written). We can see that clearly in Fig. 6.1.

According to Microsoft and Oracle an acceptable disk latency in the industry should not exceed 10 ms [6]. In the best case scenario on a 16 node cluster we are experiencing as much as 3 seconds of latency on the disks. It exceeds the industry desired standards three hundred times. In comparison, for the 8 node cluster the latency is up to 57 seconds. It is clear that is a major cause of bottlenecks.

**7. Conclusions and future work.** In this paper we have explored two case scenarios where the hardware configuration plays a large role in the performance of the cluster and will have an impact on the Big Data analytics workloads. In the first part we have established that as long as the data is evenly balanced across all the racks that make up the Hadoop platform, there are minimal overheads to accommodate the split racks. The corporations that decide to expand their Big Data environment have to remember to make use of balancing utilities to achieve that goal – otherwise the result will not reflect our findings.

During the testing process it transpired that the disk latency may cause high impact constraints. These constraints negatively impacted the duration of testing as well as utilisation of resources. In some cases we have experienced in excess of 200% or 300% increase in time required to complete benchmarks where we were expecting about 100% as we were either doubling the workload or halving the amount of resources. What we also have to keep in mind is that the testing conducted was a relatively small scale compared to what some large scale corporations deploy; their workloads also are considerably larger than the *terasort* benchmark. The hard drive seek time delays in those larger deployments may cause even bigger gap between the expected performance and what they actually achieve.

We have also found that the more the system is required to focus on seeking the *inodes* on the drives, the less it focusses on processing the workload. This, combined with lower amount of nodes, ultimately leads to lower cluster CPU utilization. It is a large financial commitment for an origination to invest in hardware, especially enterprise class hardware. It is in their best interest to make sure that those resources are used to the best of their capabilities. That is why it is important that the corporation accurately assess the size and purpose of the Hadoop platform in order to correctly choose the required size of the cluster and also invest time to optimally configure it and test for bottlenecks.

There is yet a lot to explore in the domain of Hadoop optimisation. Although we have investigated the implications of different deployment scenarios and have found answers to our questions we also have found that the CPU time on the smallest 8-node cluster was shorter than on the larger ones. As the focus of this study was biased more towards the duration of the benchmarking, this issue has not been given much attention. Future analysis of the problem from the CPU side might give us more insight into other potential bottlenecks. Also the benchmarking on larger scale clusters with more variety of benchmark suites may unveil larger performance gap in the duration of the benchmarking as well as the CPU time.

Furthermore, in the light of current emphasis on the environmental footprint caused by the datacentres

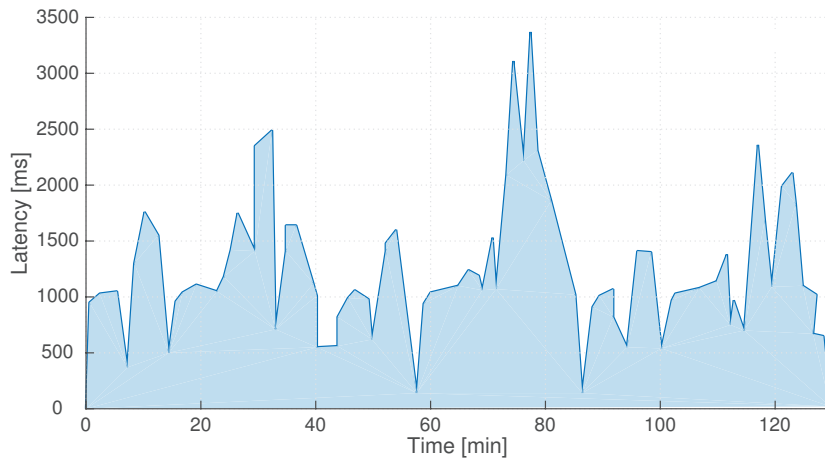

(a) 16-node test

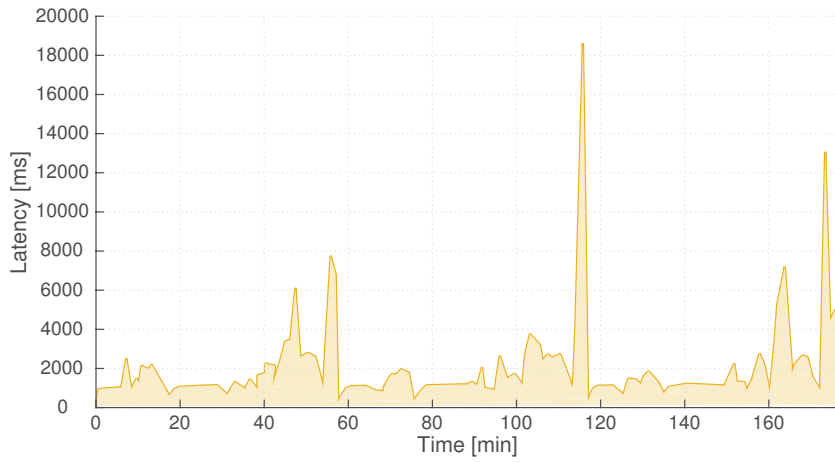

(b) 12-node test

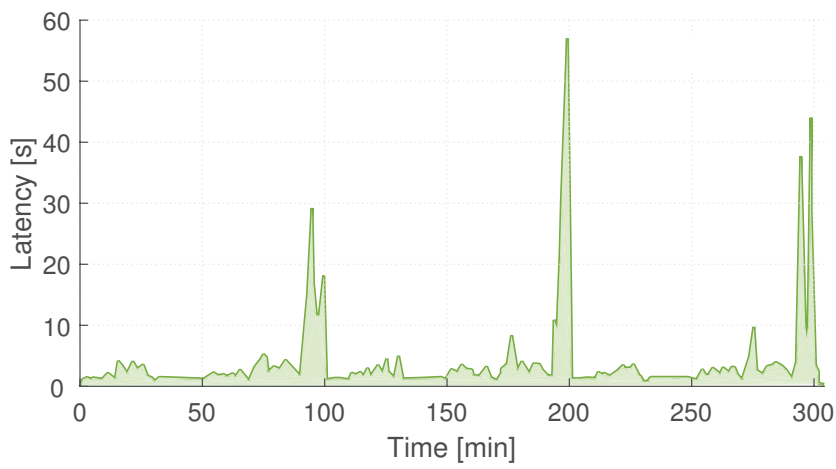

Fig. 6.1: Maximum disk latency

we would like to explore the power consumption dependence on various factors such as deployment model, configuration or number of nodes.

Also the investigation of networking choices and their impact would link to this study as the performance may be affected by the connectivity choices on the platform. Hence we plan to look into upgrading the cluster to InfiniBand in the future and present the difference in performance.

**Acknowledgements.** We gratefully acknowledge the support from of Mr. S. G. Anderson, Big Data Solutions Engineer who has enabled the benchmarking process to take place at the Cloud and Big Data lab of the Client.

#### REFERENCES

- [1] D. ALTMAN, D. MACHIN, T. BRYANT, AND M. GARDNER, *Statistics with confidence: confidence intervals and statistical guidelines*, John Wiley & Sons, 2006
- [2] R. APPUSWAMY, C. GKANTSIDIS, D. NARAYANAN, O. HODSON AND A. ROWSTRON, *Scale-up vs scale-out for Hadoop: time to rethink?*, Proceeding SOCC '13 Proceedings of the 4th annual Symposium on Cloud Computing Article No. 20, 2013.
- [3] J. DEAN, S. GHEMAWAT, *MapReduce: Simplified Data Processing on Large Clusters*, Communications of the ACM - 50th anniversary issue 51 (1), 2008, pp. 107-113
- [4] B. HEDLUND, *Understanding Hadoop Clusters and the Network*, tech. report, 2011, <http://bradhedlund.com/2011/09/10/understanding-hadoop-clusters-and-the-network>
- [5] HORTONWORKS, *Cluster Planning Guide*, tech. report, 2013, [http://docs.hortonworks.com/HDPDocuments/HDP1/HDP-1.3.0/bk\\_cluster-planning-guide/bk\\_cluster-planning-guide-20130528.pdf](http://docs.hortonworks.com/HDPDocuments/HDP1/HDP-1.3.0/bk_cluster-planning-guide/bk_cluster-planning-guide-20130528.pdf)
- [6] E. MARKOVICH, *Whats An Acceptable I/O Latency?*, tech. report, Kaminario, 2010, <http://kaminario.com/blog/whats-an-acceptable-io-latency/>
- [7] A. NADKARNI, *Trends in Enterprise Hadoop Deployments*, tech. report, IDC, 2013, [http://www.avnetweb.com/comms/avnet/redhat/liberate/resources/Trends in Enterprise Hadoop Deployments.pdf](http://www.avnetweb.com/comms/avnet/redhat/liberate/resources/Trends%20in%20Enterprise%20Hadoop%20Deployments.pdf)
- [8] E. NEMETH, *UNIX and Linux system administration handbook*, Pearson Education, 2011.
- [9] M. G. NOLL, *Benchmarking and Stress Testing an Hadoop Cluster With TeraSort, TestDFSIO & Co.*, 2011, <http://www.michael-noll.com/blog/2011/04/09/benchmarking-and-stress-testing-an-hadoop-cluster-with-terasort-testdfsio-nnbench-mrbench>
- [10] N. ROUDA, *Achieving Flexible Scalability of Hadoop to Meet Enterprise Workload Requirements*, tech. report, Enterprise Strategy Group, 2014, <http://www.emc.com/collateral/analyst-reports/esg-emc-achieving-flexible-scaling-hadoop.pdf>
- [11] E. SAMMER, *Hadoop operations*, O'Reilly Media, Inc., 2012.
- [12] M. SEVILLA, I. NASSI, K. IOANNIDOU, S. BRANDT AND C. MALTZAHN, *A framework for an in-depth comparison of scale-up and scale-out*, DISCS-2013 Proceedings of the 2013 International Workshop on Data-Intensive Scalable Computing Systems, pp. 13-18
- [13] M. E. WENDT, *Cloud-based Hadoop Deployments: Benefits and Considerations*, tech. report, Accenture Technology Labs, 2014. [https://www.accenture.com/t00010101T000000\\_w\\_w\\_/jp-ja/\\_acnmedia/Accenture/Conversion-Assets/DotCom/Documents/Local/ja-jp/PDF\\_2/Accenture-Cloud-Based-Hadoop-Deployments-Benefits-and-Considerations.pdf](https://www.accenture.com/t00010101T000000_w_w_/jp-ja/_acnmedia/Accenture/Conversion-Assets/DotCom/Documents/Local/ja-jp/PDF_2/Accenture-Cloud-Based-Hadoop-Deployments-Benefits-and-Considerations.pdf)
- [14] T. WHITE, *Hadoop: The definitive guide*, O'Reilly Media, Inc., 2012.
- [15] C. WILSON, *Who's Using Hadoop and What are They Using It For?*, 2015, <http://blog.syncsort.com/2015/06/whos-using-hadoop-and-what-are-they-using-it-for>

*Edited by:* Dana Petcu

*Received:* July 10, 2015

*Accepted:* September 30, 2015





## ENERGY EFFICIENCY OF PARALLEL MULTICORE PROGRAMS

DAVOR DAVIDOVIĆ\*, MATJAŽ DEPOLLI†, TOMISLAV LIPIĆ\*, KAROLJ SKALA\* AND ROMAN TROBEC†

**Abstract.** The increasing energy consumption of large-scale high performance resources raises technical and economical concerns. A reduction of consumed energy in multicore systems is possible to some extent with an optimized usage of computing and memory resources that is tailored to specific HPC applications. The essential step towards more sustainable consumption of energy is its reliable measurements for each component of the system and selection of optimally configured resources for specific applications. This paper briefly surveys the current approaches for measuring and profiling power consumption in large scale systems. Then, a practical case study of a real-time power measurement of multicore computing system is presented on two real HPC applications: maximum clique algorithm and numerical weather prediction model. We assume that the computing resources are allocated in a HPC cloud on a pay-per-use basis. The measurements demonstrate that the minimal energy is consumed when all available cores (up to the scaling limit for a particular application) are used on their maximal frequencies and with threads binded to the cores.

**Key words:** Energy efficiency, high-performance, maximum clique, numerical weather prediction

**AMS subject classifications.** 65Y05, 68U20

**1. Introduction.** Nowadays, a large number of hard problems is being solved efficiently on large-scale computing systems such as clusters, grids and clouds. The main building blocks of such systems are high-performance computing (HPC) clusters, since they are furthermore embedded both into grid computing systems as well as cloud computing systems [1]. A great advantage of Graphical Processor Unit (GPU) accelerators over multicore platforms was demonstrated in terms of energy efficiency [2] with an overall energy consumption for an order of magnitude smaller for the GPUs. Inside the clusters, the many-core architectures, such as GPUs [3], as well as even more specialized data-flow computers [4] are getting an increasingly large supporting role but the main processing is still performed by the multi-core main processors because of simple programming model. In this research, we analyze the energy consumption profile of the processors on a two processor multi-core computer, while varying its workload.

With the increasing number of components in large-scale computing systems the energy consumption is steeply increasing [5]. In computer systems, energy (measured in Joules) is represented as the electricity resource that can power the hardware components to do computation. On the other hand, power is the amount of energy consumed per unit time (measured in Joules per second or Watts). The ever-increasing energy consumption of large-scale computing systems causes higher operation costs (e.g. electricity bills) and has negative environmental impacts (e.g. carbon dioxide emissions). Therefore, when designing large-scale computing systems, the focus is often shifting from performance improvements to energy efficiency.

Energy can be reduced at several levels of the distributed architecture: individually on each node or hardware component-level, at the middleware level, at the networking level, and at the application level [6, 7, 8, 9].

Suboptimal use of systems resources (e.g. over-provisioning) is the primary source of energy inefficiency at middleware layer [6, 7, 10]. In over-provisioned systems, components usually consume excessive power when they are relatively idle or underutilized. This is important from the user point of view, because pay-per-use approaches stimulate users to maximally exploit rented resources during the execution period. Energy-proportional computing [11] introduces the concept of consuming energy proportional to resource utilization so that an idle or underutilized component consumes less energy. For improving the energy efficiency at middleware layer, energy-aware resource and workload management algorithms are utilized [10]. Increased network traffic in many bandwidth sensitive network applications results also in increased number of networking devices such as switches and routers and therefore in increased energy consumption. Thus, different approaches for new energy aware network protocols and network infrastructure, e.g., software defined networks and network functions virtualization, are developed also for improving energy efficiency at network layer [12, 13].

\*Rudjer Bošković Institute, Centre for Informatics and Computing, Zagreb, Croatia

†Jožef Stefan Institute, Department of Communication Systems, Ljubljana, Slovenia

A processor is a component that dominates the energy consumption of each node. Thus, most of techniques are designed to reduce energy consumption of the processor [14, 15, 16]. Most of the current processors are implemented with dynamic voltage and frequency scaling regulators to optimally adjust the voltage/frequency at run-time according to the workload behavior. Paper [17] focuses on the dynamic control of the voltage regulators in a chip multicore processors platform. Results from detailed simulations based on realistic experimental setups demonstrate up to 9% total energy saving. In [18] a minimum energy voltage scheduling on a single multi-core processor with software controlled dynamic voltage scaling is proposed. Another hardware approach for improving power management for multi-core systems is with implementation of multiple voltage islands [19]. Different frequency scaling schemes were investigated in the past that minimize the total energy consumption. The problem is even more critical in the real-time applications scheduling with pre-specified tasks' deadlines [20].

The energy consumption heavily depends on the characteristic of applications. Some applications are computationally intensive, other are data intensive, while other are hybrid of both. Energy-aware programming models, regarding various types of workloads and architectures, are required to develop energy efficient applications [21, 22]. Programming approaches, based on optimal utilization of shared hardware on-chip resources, e.g. cache memory, memory bandwidth, threads or cores, for improved energy efficiency are becoming popular because of their simple implementation. In heterogeneous multicore processors that integrate CPU cores and data-parallel accelerators (GPU) last-level cache memory can be managed to minimize the energy consumption [23]. The dynamic assignment of thread-to-core can be particularly beneficial in saving the energy [24, 25].

These approaches are particularly important in the case of modern multi-core building blocks that have a lot of options for controlling the execution parameters, e.g., number of cores, system frequency, core binding, etc. The energy can be thus saved at all levels of large-scale architectures, even dynamically, depending on the application program characteristics.

In this research we experimentally test the effects of the workload, core binding strategies, and frequency scaling on energy requirements for two existing applications. We build on the previous research [26] with addition of a communication intensive use case that significantly influences energy consumption. Our approach does not require any change in the original source code of the applications and is thus instantly applicable on a wide range of applications without inspecting their code. Our findings suggest that modern multi-core architectures perform best both energy-wise and performance-wise when all of the cores are used, the frequency is not throttled and threads are not allowed to migrate between cores.

The paper starts with a brief survey of the current approaches for measuring and profiling power consumption in Sect. 2. In Sect. 3, two different use cases are presented together with the description of the experimental computer for software-based energy measurements. In Sect. 4, the obtained results are shown under various test conditions, which demonstrate significant differences in the consumed energy. The results are discussed in more details in Sect. 5 in order to deduce some useful rules for users of HPC cloud resources. The paper concludes with the summary of results and directions for further work.

**2. Energy Measurement and Profiling Approaches.** The essential step towards the energy-efficiency is accurate, reliable and continuous energy consumption measurement of the system components. Energy measurement and profiling approaches can be classified as hardware-based, software-based and hybrid. In the following subsections the basic characteristics of hardware-based and software-based approaches are outlined, based on two extensive survey papers [27, 28].

**2.1. Hardware-based Energy Measurement.** Hardware-based energy measurement approaches are implemented with various instruments or sensors that measure the electrical current or the consumed energy as functions of time on different computation, storage or networking segments such as CPUs, motherboards, servers or racks. An energy measurement obtained with meters is a direct and straight-forward approach. A digital multi-meter collects the voltage or the energy samples of the measured segment in pre-specified time intervals and sends the measurements through a data link connected to the data collection system. Such meters are mainly used to measure the direct current (DC) power and are connected between the power supply and the measured segment. On the other hand, there are other meters (e.g. "Watts UP" [29]) that can directly measure the power consumption on the alternating current (AC) lines. Another example of a simple meter with limited precision is a clamp meter that has a larger measurement range and can be used to measure the energy of segments with high currents. AC meters, however, only measure the power consumption on the system level.



In their simplicity, multi-meters cannot be used when a higher control of the measurement process is required. In those cases, more complex devices have to be used that are often custom designed. In 2000, Viredaz et al. designed a platform called *Itsy* to measure the energy consumption of mobile devices [30]. Another example of a complex device to measure the energy consumption is a single board on computer called *PLEB* [31]. PLEB uses a design with a set of on-board current sensors, and an analogue-to-digital converter with a micro-controller to read the sensors. Unlike *Itsy*, which measures only the energy consumption of mobile devices, PLEB can be used to measure the energy of processors, memories, flash drivers, and I/O components. Precise and fine-grained measuring is also available through *PowerPack*, a system for power profiling on typical clusters or other distributed systems [32]. PowerPack measures power on system DC power lines and then maps it to individual components of the system, using computer models. It also measures AC power consumption to derive the efficiency of AC to DC conversion. All measurement are processed on a separate computer to ensure the power profiling does not impact the system under test. PowerPack profiling is enabled by the provided API calls, that link the application under test to control and communicate with the meter control process and thus correlate the power profiles with the application source code. Since PowerPack uses both hardware- and software-based methods of measurements it is actually a hybrid meter.

**2.2. Software-based Energy Measurement.** The disadvantages of hardware-based energy measurement techniques are in their dependence on the expensive sensing components and complex additional hardware design. Considering the expensive and cumbersome setup, they are also not well suited for online monitoring and designing of energy-aware policies. In contrary, software-based approaches can be used to supply more fine-grained online information, although with reduced accuracy. They are more flexible because they can be applied to different platforms without changing the hardware.

A software-based approach usually builds power/energy models to estimate the energy consumption at the CPU instruction level, program block level, process level, hardware component level or full system level. These models are built based on selection and optimization of power/energy indicators of a software or a hardware component of interests. Regarding the power/energy indicators type, software based approaches can be classified as system profile-based approaches or hardware performance counter (PMC) based approaches.

System profile or system events are a set of performance statistical information supplied by the operating system or a special software. These events can describe the current state of hardware, software, and operating system. For example, Joulemeter [33], tracks the energy consumption of a virtual machine using power/energy models for three system hardware components, i.e. CPU, memory and disk. The CPU energy model uses CPU utilization, the memory energy model uses the number of last level cache misses, while the disk energy model uses the bytes of data written to and read from the disk as inputs to their energy consumption estimates.

Hardware performance counters are a group of special registers that count the hardware-related activities within the computer systems. The PMC-based modelling [34] is implemented either with top-down or bottom-up approaches. The first do not depend on modelled architecture thus enabling a fast and an easy deployment [35], while the second depends on the underlying architecture and is therefore able to produce more informative, responsive and accurate power/energy models. The bottom-up approach enables a breakdown of the energy consumption per architectural components, but is more complex to deploy and less portable than the simpler top-down approach [36].

**3. Use Cases and Experimental Setup.** The use cases, presented in this section, have been used as test applications for the analyses of energy consumption using real-time power monitoring. The experimental computer comprised multi-core components, which are the main building blocks of the contemporary large-scale computing systems, including those offered by the cloud infrastructure providers. The two use cases are of different types based on their scalability characteristics. The first is characterized by high scalability on the multi-core computer systems, and second is characterized by high communication costs, which limit the scalability. The use cases are also implemented with different parallelization techniques, master-slave parallelization and domain decomposition, and are consequently not equally sensitive to the computer architecture details, such as the amount of cache memory and the number of its levels.

Under the assumption that energy consumption scales linearly with the problem size on the selected use cases, we chose to experiment on small problems. With this assumption, the obtained results should also be representative for the larger problems.

**3.1. Maximum Clique Algorithm.** For the first use case, we use an application that implements the parallel maximum clique algorithm [37], which is essentially a recursive program for traversing in a search tree under the branch and bound strategy. The algorithm takes an input graph and returns its maximal fully connected sub-graph. The maximum clique algorithm is characterized as a compute-bound algorithm and will thus benefit if more processing units are employed for its solution. It is parallelized by using threads for searching the tree branches asynchronously. The threads are synchronized only when accessing one global variable - the size of the current clique. On large graphs - these are graphs that take at least a few seconds to search through - the algorithm experiences a near-linear speedup on average.

As in all branch and bound approaches, the order in which the branches are searched influences the time required to find the optimal solution. In general, the concurrent search of several branches influences on which branches are searched and which not, which results in varying efficiency of the approach when used on various number of threads. The effects of parallel speedup, which influences the energy consumption greatly, can thus be hidden in the noise, generated by the varying branch and bound efficiency, which could make this algorithm tricky to evaluate.

For our experiments, a small graph named p\_hat300-3 from the DIMACS collection of benchmark graphs for the maximum clique problem [38] was used. This graph comprises 300 vertices and 33390 edges, while its maximum clique spans over 36 of its vertices. The time required to find the maximum clique of p\_hat300-3 on a single core of the experimental computer setup is about 1.3 seconds. A quality of this graph when searched by the selected maximum clique algorithm is also that it experiences relatively smooth speedup with almost constant branch and bound efficiency across the range of the experimented number of cores. By using this graph, we streamline the experiments that would otherwise have to be made on a large set of input graphs just to cover the average algorithm speedup.

**3.2. WRF meteorological model.** The second use case is a public domain Weather Research and Forecasting model (WRF-ARW) [39, 40]. This is a next-generation numerical weather prediction system designed to serve both operational forecasting and atmospheric research needs. The model, based on the input parameters and data, gives as an output a prediction of several atmospheric phenomena such as temperature, moisture, wind speed and direction, and precipitations. The model operates on a target geographical domain that is divided into a grid. The distance between the grid points is called resolution. To increase the accuracy of the forecast for a specific region, a smaller nested domain is defined within the main domain. The forecast is conducted at each grid point on multiple vertical levels (3D grid) for each time step.

In the experiments we compute a 6-hour weather forecast for Croatia with one nested domain. The main domain consists of  $100 \times 68$  points and the nested domain of  $58 \times 61$  points with 18 and 6 km resolution, respectively, and 27 vertical levels. The time step is 2 minutes for the main, and 40 seconds for the nested domain, thus, the number of iterations/steps is 180 and 1080 for the main and nested domain, respectively. The total number of performed steps, for the 6-hour simulation, is  $1.36 \times 10^8$ .

The model applies different model for parallelism: MPI, OpenMP and hybrid MPI+OpenMP, that enable execution on various computing architectures such as distributed and shared-memory (SMP) systems, clusters of SMPs, and vector and multiprocessors base systems. The parallelism in the model is achieved by decomposition of geographical domain (a domain on which the model simulation is run) into a 2D grid. The grid consists of *patches*, the rectangular sections of the model domain, each one allocated to a distributed memory node and executed by one MPI process. On a node level, each patch is further divided into *tiles*, which are the square sections of a patch, allocated to a shared-memory processor and each tile is executed by a single thread (i.e. OpenMP thread). Since our testing system is a shared-memory multi-core machine, only the OpenMP parallel version was considered. Thus, the domain is decomposed into 1 patch and the number of tiles equals to the number of threads (in our case up to 12 threads). The tiles are processed concurrently by different threads, but, if the tile size cannot fit into the CPU's cache memory, an additional communicational overhead is exhibited.

In contrast to the maximum clique algorithm, the performance of WRF is significantly leveraged by the communication and data exchange between the tiles that limit the scalability of the model and is thus concerned as a memory-bound algorithm.

**3.3. Experimental Setup.** The performance of the use cases was evaluated in terms of execution time and the corresponding power consumption. All results are shown as the average of 15 experiments. The experimental computing system was running Ubuntu 12.04 server version OS and was composed of a dual CPU 2.3 GHz Intel Xeon E5-2630, each of CPUs with six physical cores. Both applications were compiled with the GNU Compiler Collection (GCC), with parallelization flags `-O3 -march=native` and with `-lpthread` for the MaxClique problem and `-fopenmp` for the WRF problem to exploit multi-threaded level of parallelism.

Use cases were executed on a varying number of cores up to the maximum available cores  $n_c = [1..12]$ , two CPU clock frequencies  $f = [1.2 \text{ GHz}, 2.3 \text{ GHz}]$  which represent the minimum and maximum software settings for the clock frequency in the experimental computer, and two binding policies - *bind* and *nobind*. The *bind* policy stands for enforced binding of the  $n$ -th thread on the  $n$ -th core (as listed by the OS), and *nobind* denotes that binding is not enforced and thread management is completely up to the OS. It is worth noting that OS tends to migrate threads among cores often, which is expected to adversely effect performance by causing some unneeded cache misses in the core-local caches. On the other hand, the OS tends to distribute threads equally among all available CPUs, and thus make available to the application the CPU-local caches of all the installed CPUs. The effects of more caches can be difficult to predict, since they depend both on the application and on the values of parameters to the application, but more often than not, they correspond to a better performance [41].

Additional feature of core binding is that when all the required threads can be loaded onto cores of a single CPU, the second CPU can be idle most of the time, unless loaded by the OS processes. Depending on the OS and the processor used, the idle processor can be put into one of its sleep states. The OS indexes cores of the first CPU as [1..6] and the cores of the second CPU as [7..12]. Therefore, while the enforced binding is used and the number of cores is set to 6 or lower, only the cores of the first CPU will be used by the application, enabling the OS to power down the second CPU. When binding is not enforced, OS tends to distribute the threads among cores of both CPUs, even when only 2 threads are requested. OS also switches threads among available cores at random intervals, which increases the number of cache misses, and consequently lowers the performance of the application. Binding of threads to processor cores is performed through the *pthread API* for the MaxClique case and through the *likwid-pin* tool, which comes with likwid Performance monitoring and benchmarking suite [42], for the WRF case.

Threads that are bound to cores are known to perform well by minimizing the low level cache flushing and reloading, which happens if threads are moved between cores. The effect is very application dependent though. In addition, when the program is executed on cores of multiple CPUs, instead of a single CPU, more cache is available to it, which can speedup the execution [41]. This effect is very application and problem dependent and rarely visible outside a narrow range of problem sizes. In our case there are only two CPUs available, which makes the possible effects of such experiment severely limited, therefore we do not test such arrangement at all.

## 4. Experimental results.

**4.1. Maximum clique program.** In this section we demonstrate the impacts of scaling the number of computational cores, CPU frequencies and binding policies on the performance and energy consumption on our use cases. The total execution time, power and energy consumption of the two use cases are shown in Figs. 4.1, 4.2 and 4.3, respectively. Since the measurement of the performance and energy consumption can be influenced by other running processes on the system (e.g. those managed by OS), we repeated each test 15 times (with the same experimental setup). The results presented in the figures are calculated as an average value of these repeated runs.

Figure 4.1(a) shows that the program for solving the maximum clique problem scales well on all test configurations, with the speedup between 8.1 and 9.4 on 12 cores for different clock frequencies and binding policies. The respective power consumption and energy consumption for the maximum clique problem are shown in Fig. 4.2(a), and Fig. 4.3(a), respectively. A closer look at Fig. 4.3(a) reveals that at higher frequencies, binding is significantly more energy efficient than leaving the thread management to OS, which spreads and moves the threads around the cores of both CPUs. Also, note that by binding the threads to physical cores, both the power and energy consumption are slightly reduced if the clock frequency is at its maximum while no significant difference is noticed if the clock frequency is at its minimum.

The evident finding, in general, is that running maximum clique program on less cores causes higher energy consumption. The second finding is that binding has positive effect on the power consumption but not on the

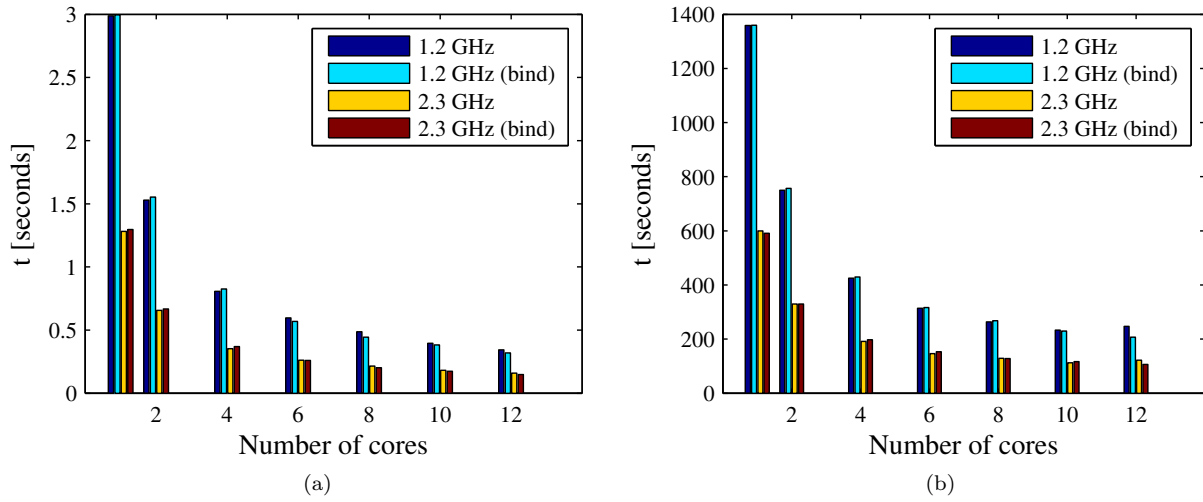

Fig. 4.1: Execution times for the maximum clique program (a) and the WRF model (b) as functions of the number of used cores, clock frequency, and binding policy.

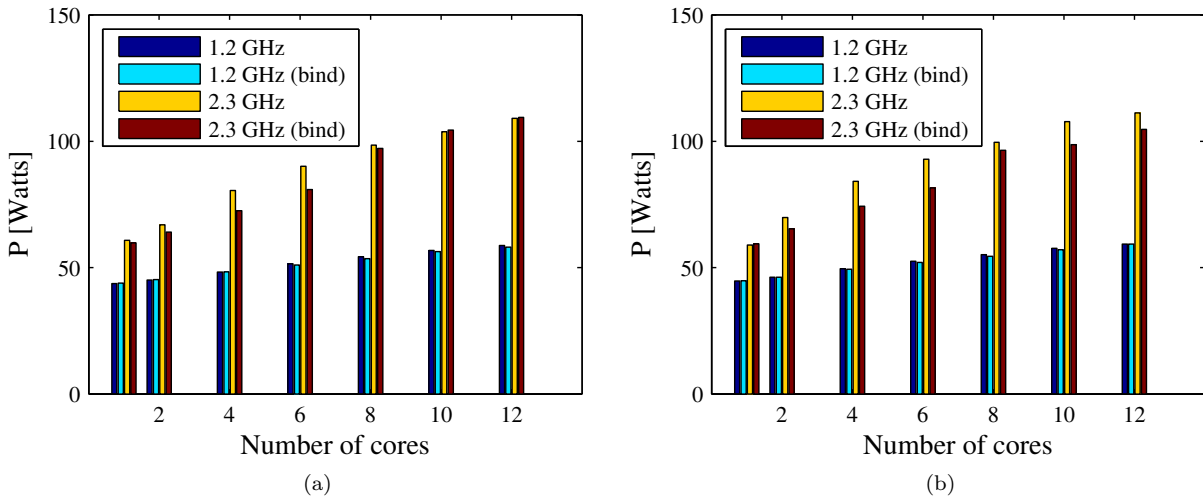

Fig. 4.2: Power consumption for the maximum clique program (a) and for the WRF model (b) as functions of the number of used cores, clock frequency, and binding policy.

execution time. The enforced binding only uses one CPU for up to 6 threads (cores indexed 1 through 6 are all on the first CPU), causing the second CPU to be idle and drawing less power, thus explaining the observed lower power consumption for a low number of cores. At more than 6 threads, both CPUs become active and the power consumption equalizes for both binding policies. The effects on execution time are both positive and negative. Binding threads to cores results in shorter execution times for the number of cores equal to or larger than 6, which can be attributed to the better data locality. Binding also causes longer execution times for the number of cores between 1 and 4, even though the data locality should be better no matter the number of cores used. The *bind* policy restricting the cache access to only one CPU thus seem to have greater performance effect

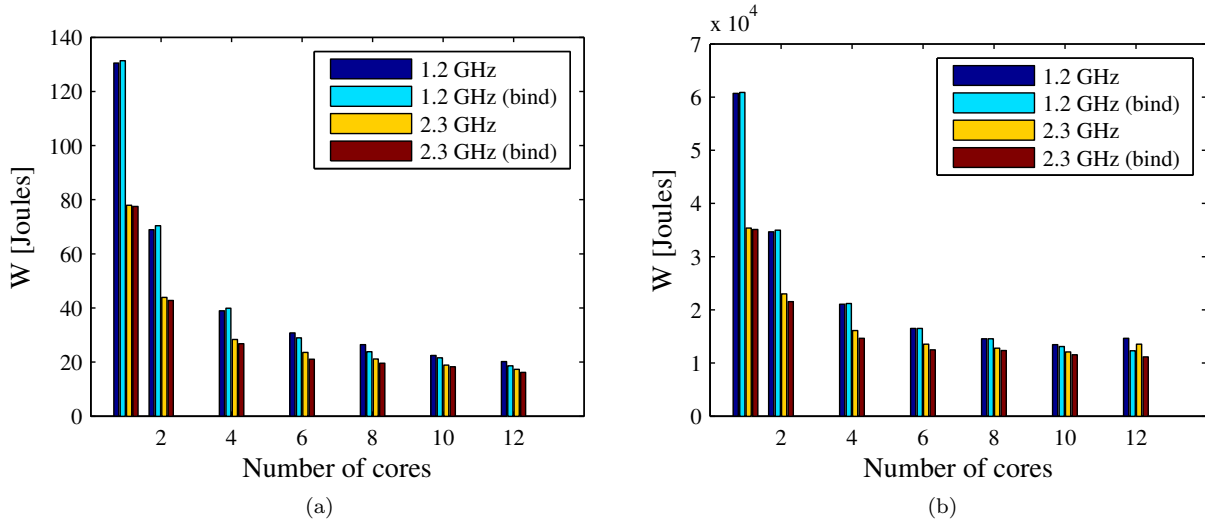

Fig. 4.3: Energy consumption for the maximum clique program (a) and for the WRF model (b) as a function of the number of used cores, clock frequency, and binding policy.

on 1 – 4 cores than the improved data locality. Although the differences in performance are small, they are mostly statistically significant. Table 4.1 summarizes the differences in policy performance separately for each performance measure ( $t$ ,  $P$ , and  $W$ ), each tested frequency and each number of cores. For each set of parameter values, the performance is expressed by two statistics - *ratio* and *p-value*. *Ratio* is the mean ratio between the value obtained with *bind* policy and the value obtained with *nobind* policy. *P-value* is the p-value of the paired Student's *t*-test, on the null hypothesis that the performance is the same for both policies. Statistics are collected from 15 repeats of the maximum clique program execution for each set of input parameters (binding policy, number of cores, and clock frequency).

Table 4.1: Difference in performance of binding policies expressed as the statistics of *bind* policy relative to *nobind* policy for the maximum clique program.

cores		1	2	4	6	8	10	12
Frequency = 1.2 GHz								
t	ratio	1.00	1.02	1.02	0.95	0.91	0.97	0.93
	p-value	$\leq 0.01$	$\leq 0.01$	$\leq 0.01$	$\leq 0.01$	$\leq 0.01$	$\leq 0.01$	$\leq 0.01$
P	ratio	1.00	1.00	1.00	0.99	0.99	0.99	0.99
	p-value	$\leq 0.01$	$\leq 0.01$	0.38	$\leq 0.01$	$\leq 0.01$	$\leq 0.01$	$\leq 0.01$
W	ratio	1.01	1.02	1.02	0.94	0.90	0.96	0.92
	p-value	$\leq 0.01$	$\leq 0.01$	$\leq 0.01$	$\leq 0.01$	$\leq 0.01$	$\leq 0.01$	$\leq 0.01$
Frequency = 2.3 GHz								
t	ratio	1.01	1.02	1.05	0.99	0.94	0.96	0.93
	p-value	0.01	$\leq 0.01$	$\leq 0.01$	0.14	$\leq 0.01$	$\leq 0.01$	$\leq 0.01$
P	ratio	0.98	0.96	0.90	0.90	0.99	1.01	1.00
	p-value	0.06	$\leq 0.01$	$\leq 0.01$	$\leq 0.01$	$\leq 0.01$	0.02	0.34
W	ratio	0.99	0.97	0.94	0.89	0.93	0.97	0.94
	p-value	0.63	0.05	$\leq 0.01$	$\leq 0.01$	$\leq 0.01$	$\leq 0.01$	$\leq 0.01$

**4.2. WRF program.** Our second use case is the WRF model, a computationally-intensive problem whose performance is tackled by the communication speed and the size of the cache memory. As presented in Fig. 4.1(b), the scalability rate drops with the number of cores used, for both clock frequencies and binding policy configurations. The problem scales well up to 10 cores (speedup is between 4.3 and 5.9), but exhibits modest speedup on 12 cores only for variants using the *bind* policy, while the execution time for the *nobind* variants already increases. In contrast to the maximum clique algorithm, the speedup on 12 cores is a bit lower, and amounts between 4.9 and 6.5 due to a higher communication cost between the running threads. The explanation for that lays in the fact that when more cores are utilized, the tile size that can fit into the cache decreases, which increases the number of cache misses.

The corresponding power consumption and the energy consumption are illustrated in Figs. 4.2(b) and 4.3(b), respectively. Similar to the maximum clique problem, the tests show that the best energy-efficient strategy is to use all the available cores at their maximum performance. The same statistics as for the Maximum clique problem are gathered from 15 runs of the WRF model and summarized on Table 4.2. These show that for the clock frequency of 1.2 GHz, on one hand, binding has a very limited effect on execution time and power consumption (except on 12 cores), regardless of the binding policy. For the clock frequency of 2.3 GHz, on the other hand, binding the threads to physical cores reduces the power consumption considerably, while it does not change the execution times much.

Table 4.2: Difference in performance of binding policies expressed as the statistics of *bind* policy relative to *nobind* policy, for the WRF model

cores		1	2	4	6	8	10	12
Frequency = 1.2 GHz								
t	ratio	1.00	1.01	1.01	1.01	1.02	0.98	0.84
	p value	¡0.01	¡0.01	¡0.01	¡0.01	¡0.01	0.35	¡0.01
P	ratio	1.00	1.00	1.00	0.99	0.99	0.99	1.00
	p value	0.09	0.74	0.1	¡0.01	¡0.01	¡0.01	0.71
W	ratio	1.00	1.01	1.01	1.00	1.00	0.98	0.84
	p value	0.03	¡0.01	¡0.01	0.93	0.17	0.07	¡0.01
Frequency = 2.3 GHz								
t	ratio	0.99	1.00	1.03	1.05	1.00	1.04	0.88
	p value	¡0.01	0.94	¡0.01	¡0.01	0.85	¡0.01	¡0.01
P	ratio	1.01	0.94	0.88	0.88	0.97	0.92	0.94
	p value	¡0.01	¡0.01	¡0.01	¡0.01	¡0.01	¡0.01	¡0.01
W	ratio	0.99	0.94	0.91	0.92	0.97	0.96	0.82
	p value	0.13	¡0.01	¡0.01	¡0.01	0.02	¡0.01	¡0.01

**4.3. Energy consumption in detail.** The energy consumption - calculated as power consumption times execution time and shown in Tables 4.1 and 4.2 - indicates that energy-wise, best strategy is using all available cores in combination with the thread binding strategy. This finding holds even though the WRF program exhibits relatively low speedup at 12 cores.

A significant observation on both use cases is the jump in the power consumption from 6 to 8 cores when threads are bound to cores. For up to 6 cores all threads are bound to one CPU, and the second CPU is in idle state, while for 8 or more cores the threads are distributed on both CPUs, which increases the power consumption in one large step (observe the jump between 6 and 8 cores bind versions, red color bars, in Fig. 4.2). Note that the energy consumption continues to decrease due to the lower computational time caused by adding additional cores. Once the second CPU is active, adding more cores again causes the execution time and the energy consumption to decrease. Therefore using only one processor with all available cores is worth considering for programs that might experience worse speedups than our use cases.

For the last result, we look at the statistics that we gather from the 15 repetitions of the same measurement. Figure 4.4 is the box plot of the WRF model energy consumption on the higher clock frequency (2.3 GHz). It clearly shows the smaller variability and the lower number of outliers in the energy consumption if the *bind*

policy is used, compared to the *no-bind* policy. Note that the results for the maximum clique use case on the higher clock frequency are very similar, while the results for both use cases on the low frequency display much less difference in binding policies. These results indicate the level of randomness inserted into the measurements by the OS regulated thread management.

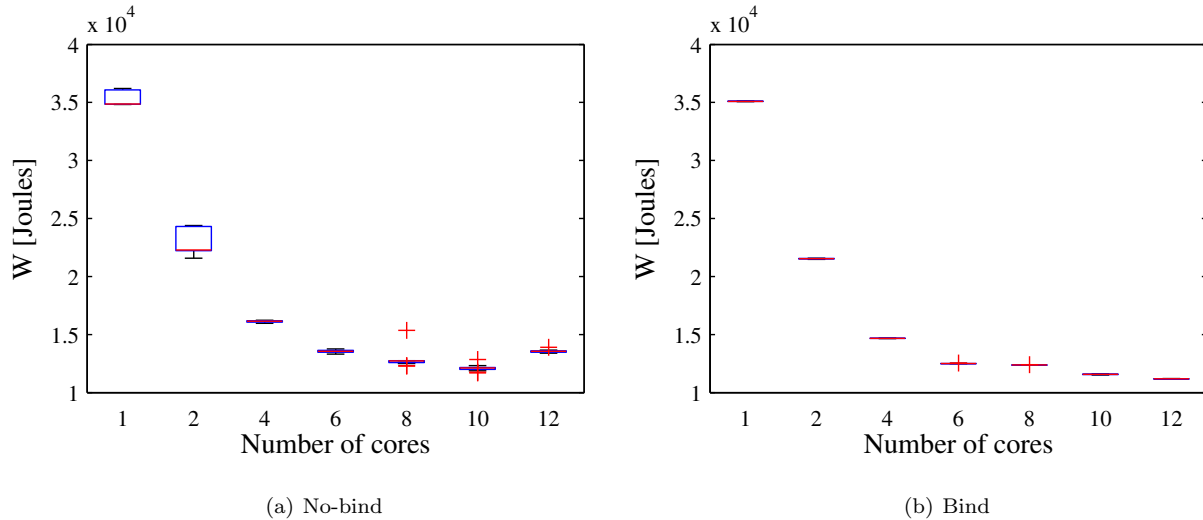

Fig. 4.4: Energy consumption for WRF model as a function of the number of used cores and binding policy - (a) the no-bind policy, and (b) the bind policy. Graphs show the median (red line), 25 and 75 percentiles (blue box), min and max values (blue whiskers), and outliers (red plus signs).

**5. Discussion.** A simple experimental study of a real-time power measurement in a multi-core computing system was presented. The energy consumption of two HPC parallel algorithms was measured, by the PCM library, as a function of the number of cores, the system clock frequency, and the binding policy. The main results of this research are listed below.

While we often believe that the two most influential factors on energy consumption are clock frequency and execution time, it turns out that execution time dominates clock frequency. The lower the execution time, the higher the energy efficiency, regardless of the clock frequency. This is caused by the relatively high baseline power consumption of the CPU, memory, and the rest of the system, which was not even considered in this study.

Second result shows that even less efficient parallel programs perform better, energy-wise, if executed on more cores. Note that the baseline consumption of the other computer parts, which was not included in the study, would again strengthen this finding even further. Of course, such a conclusion holds under the assumption that the computer is not multitasking - its unused cores actually remain idle and that the idle time of the computer can be ignored, which, for example, is not the case on computer resources rented for a fixed amount of time. A scenario where our findings hold is for computer resources that are rented on the cloud for the time of the execution only.

Third result is that by the same number of cores the energy consumption is lower if the cores are concentrated on a single CPU and not spread across more CPUs. It appears that the given CPU can enter a much more efficient power saving state if no cores are active than if even a single core is used. This, however, on our tests holds only for the high frequency and not for the low frequency, where the power consumption is not significantly different no matter how the threads are positioned on the CPUs. This could mean that the tested CPU could not throttle into a state with power consumption that is lower than when the clock frequency is the lowest. It should be noted though, that these results could be more profound - motherboard could use some additional energy for the inter-CPU communication when both CPUs are active, but motherboard is currently

not monitored.

The fourth result is that the energy consumption for *bind* policy exhibits very small variation of the energy consumptions between runs as illustrated in Fig. 4.4. This enables a precise and accurate prediction of the energy consumption, especially if observed from the perspective of the cost reduction in utilizing public clouds with the pay-per-use policy. Small variation is possible because no flushing and reloading of cache are performed since threads are not moved among the cores. On the other hand, the *nobind* strategy, especially when applied on a smaller number of cores, exhibits a large difference between the best and the worst run. This can be explained by the fact that when the number of threads is small, OS is more likely to switch threads among cores and CPUs, causing cache flushing on various cache levels.

**6. Conclusion.** The obtained results show that idle power consumption of the CPU is significant. To achieve highest energy efficiency, the whole application should be executed in the shortest possible time. This can be achieved with cores at the highest possible system clock frequency, threads bound to cores and using the maximum number of cores at which the speedup is still satisfactory high. To apply the optimization of the energy consumption on general applications, a profiling of their speedup is required. In the tested cases, for example, each additional core causes about 4.5% (mean of measured increases on the high clock frequency setting) higher power consumption of the CPU. Therefore, when deciding whether to use  $n$  cores or  $n + 1$  cores, one should favour  $n$  cores only if the relative decrease in execution time when raising the number of cores to  $n + 1$  is less than 4.5%.

Aside from affecting the execution time, binding threads to cores also directly lowers the power consumption by limiting the number of cache flushes and main memory reads. This has been demonstrated in the WRF model case, but not in the maximum clique case, since the WRF model is a memory intensive application, while the maximum clique is more processing intensive. Caching is thus proved as another area, where more control should have to be given to the program designer, to be able to get maximal performance of the computer at the minimal energy cost.

To optimize the energy consumption more aggressively, one should be able to shut down the computing cores and banks of memory completely, or at least put them in a sleep state with a significantly lower power consumption. There are also some interesting possibilities of executing programs on multiple cores with heterogeneously set clock frequencies. In scenarios when computing resources are reserved for a predefined time frame - as in some Clouds services for example - measuring the power consumption during the whole time frame would be more to the point, instead of just for the time the program is executing. For such scenarios the role of the execution time in the energy consumption will be lowered and throttling the clock frequency might start to pay off. These are the topics of our current research and future work.

**Acknowledgement.** The work presented in this paper has been supported by the Ministry of Education, Science, Culture and Sport of the Republic of Slovenia and the Ministry of Science, Education and Sports of the Republic of Croatia under the bilateral project 'Energy Efficiency at Distributed Computing Systems', and partially supported by EU under the COST programme Action IC1305, 'Network for Sustainable Ultrascale Computing (NESUS)'.

#### REFERENCES

- [1] G. L. VALENTINI, W. LASSONDE, S. U. KHAN, N. MIN-ALLAH, S. A. MADANI, J. LI, L. ZHANG, L. WANG, N. GHANI, AND J. KOLODZIEJ, *An overview of energy efficiency techniques in cluster computing systems*, Cluster Computing, 16 (2011), 1, pp. 3–15.
- [2] J. LIU, D. FELD, Y. XUE, J. GARCKE, T. SODDEMANN, *Multicore Processors and Graphics Processing Unit Accelerators for Parallel Retrieval of Aerosol Optical Depth From Satellite Data: Implementation, Performance, and Energy Efficiency*, IEEE Journal of Selected Topics in Applied Earth Observations and Remote Sensing, (2015), doi=10.1109/JSTARS.2015.2438893, Article in Press.
- [3] G. KOSEC AND P. ZINTERHOF, *Local strong form meshless method on multiple Graphics Processing Units*, CMES: Computer Modeling in Engineering and Sciences, 91 (2013), pp. 377–396.
- [4] M. J. FLYNN, O. MENCER, V. MILUTINOVIC, G. RAKOCEVIC, P. STENSTROM, R. TROBEC, AND M. VALERO, *Moving from Petaflops to Petadata*, Commun. ACM, 56 (2013), pp. 39–42.
- [5] A. C. ORGERIE, L. LEFEVRE, AND J. P. GELAS, *Demystifying energy consumption in Grids and Clouds*, Green Computing Conference, 2010 International, (2010), pp. 335–342.



- [6] A. BEGLOGLAZOV, R. BUYYA, Y. C. LEE, AND A. ZOMAYA, *A Taxonomy and Survey of Energy-Efficient Data Centers and Cloud Computing Systems*, *Advances in Computers*, 82 (2011), 2, pp. 47–111.
- [7] C. CAI, L. WANG, S. U. KHAN, AND J. TAO, *Energy-aware high performance computing - A taxonomy study*, in *Proceedings of the International Conference on Parallel and Distributed Systems - ICPADS*, 2011, pp. 953–958.
- [8] J. SHUJA, S. A. MADANI, K. BILAL, K. HAYAT, S. U. KHAN, AND S. SARWAR, *Energy-efficient data centers*, *Computing*, 94 (2012), pp. 973–994.
- [9] J. MUKHERJEE AND S. RAHA, *Power-aware Speed-up for Multithreaded Numerical Linear Algebraic Solvers on Chip Multicore Processors*, *Scalable Computing: Practice and Experience*, 10 (2009), 2, pp. 217–228.
- [10] A. Y. ZOMAYA AND C. L. YOUNG, *Energy-efficient Distributed Computing*, *Awareness Magazine*, January (2012).
- [11] L. A. BARROSO AND U. HÖLZLE, *The case for energy-proportional computing*, *Computer*, 40 (2007), pp. 33–37.
- [12] K. BILAL, S. U. K. KASHIF, S. A. MADANI, K. HAYAT, M. I. KHAN, N. MIN-ALLAH, J. KOLODZIEJ, L. WANG, S. ZEADALLY, AND D. CHEN, *A survey on Green communications using Adaptive Link Rate*, *Cluster Computing*, 16 (2012), 3, pp. 575–589.
- [13] A. P. BIANZINO, C. CHAUDET, D. ROSSI, AND J.-L. ROUGIER, *A survey of green networking research*, *IEEE Communications Surveys and Tutorials*, 14 (2012), pp. 3–20.
- [14] Y. LIU AND H. ZHU, *A survey of the research on power management techniques for high-performance systems*, *Software - Practice and Experience*, 40 (2010), pp. 943–964.
- [15] N. B. RIZVANDI AND A. Y. ZOMAYA, *A Primarily Survey on Energy Efficiency in Cloud and Distributed Computing Systems*. arXiv preprint, 2012.
- [16] S. LIBUTTI, G. MASSARI, P. BELLASI, W. FORNACIARI, *Exploiting performance counters for energy efficient co-scheduling of mixed workloads on multi-core platforms*, *ACM International Conference Proceeding Series*, (2014), pp. 27–32.
- [17] W. LEE, Y. WANG, M. PEDRAM, *Optimizing a Reconfigurable Power Distribution Network in a Multicore Platform*, *IEEE Transactions on Computer-Aided Design of Integrated Circuits and Systems*, 34 (2015), 7, pp. 1110–1123.
- [18] A. MISHRA, A. K. TRIPATHI, *Energy efficient voltage scheduling for multi-core processors with software controlled dynamic voltage scaling*, *Applied Mathematical Modelling*, 38 (2014), 14, pp. 3456–3466.
- [19] S. PAGANI, J.-J. CHEN, M. LI, *Energy efficiency on multi-core architectures with multiple voltage islands*, *IEEE Transactions on Parallel and Distributed Systems*, 26 (2015), 6, pp. 1608–1621.
- [20] G. M. TCHAMGOUE, J. SEO, K. H. KIM, Y.-K. JUN, *Compositional power-aware real-time scheduling with discrete frequency levels*, *Journal of Systems Architecture*, 61 (2015), 7, pp. 269–281.
- [21] C. ZHANG, K. HUANG, X. CUI, AND Y. CHEN, *Power-aware programming with GPU accelerators*, in *Proceedings of the 2012 IEEE 26th International Parallel and Distributed Processing Symposium Workshops, IPDPSW 2012*, 2012, pp. 2443–2449.
- [22] C. LIVELY, X. WU, V. TAYLOR, S. MOORE, H.-C. CHANG, C. YI SU, AND K. CAMERON, *Power-aware predictive models of hybrid (MPI/OpenMP) scientific applications on multicore systems*, *Computer Science - Research and Development*, 27 (2012), pp. 245–253.
- [23] A. HOLEY, V. MEKKAT, P.-C. YEW, A. ZHAI, *Performance-energy considerations for shared cache management in a heterogeneous multicore processor*, *ACM Transactions on Architecture and Code Optimization*, 12 (2015), 1, pp. 1–29.
- [24] V. PETRUCCI, O. LOQUES, D. MOSS, R. MELHEM, N. A. GAZALA, S. GOBRIEL, *Energy-efficient thread assignment optimization for heterogeneous multicore systems*, *ACM Transactions on Embedded Computing Systems*, 14 (2015), 1, pp. 1–26.
- [25] M. LI, Y. ZHAO, Y. SI, *Dynamic core allocation for energy-efficient thread-level speculation*, *Computational Science and Engineering (CSE)*, 2014 IEEE 17th International Conference on, 2014, pp. 682–689.
- [26] R. TROBEC, M. DEPOLLI, K. SKALA, AND T. LIPIC, *Energy efficiency in large-scale distributed computing systems*, in *Information Communication Technology Electronics Microelectronics (MIPRO)*, 2013 36th International Convention on, May 2013, pp. 253–257.
- [27] S. BENEDICT, *Energy-aware performance analysis methodologies for HPC architectures - An exploratory study*, *Journal of Network and Computer Applications*, 35 (2012), pp. 1709–1719.
- [28] H. CHEN AND S. WEISONG, *Power Measuring and Profiling: the State of Art*, andbook of Energy-Aware and Green Computing, pp. 649–674.
- [29] *Watts up*. <https://www.wattsupmeters.com>, 2014.
- [30] M. A. VIREDAZ AND D. A. WALLACH, *Power evaluation of Itsy version 2.3*, tech. report, 2000.
- [31] D. C. SNOWDON, S. M. PETERS, AND G. HEISER, *Power measurement as the basis for power management*, *Proceedings of the 2005 Workshop on Operating System Platforms for Embedded Real-Time Applications*, Palma, Mallorca, Spain, 2005.
- [32] A. Y. ZOMAYA AND Y. C. LEE, *Energy Efficient Distributed Computing Systems*, Wiley-IEEE Computer Society Pr, Hoboken, NJ, USA, 1st ed., 2012.
- [33] A. KANSAL, F. ZHAO, J. LIU, N. KOTHARI, AND A. A. BHATTACHARYA, *Virtual machine power metering and provisioning*, in *Proceedings of the 1st ACM Symposium on Cloud Computing, SoCC '10*, 2010, pp. 39–50.
- [34] R. BERTRAN, M. GONZALEZ, X. MARTORELL, N. NAVARRO, AND E. AYGUADE, *Counter-based power modeling methods: Top-down vs bottom-up*, *The Computer Journal*, 56 (2013), pp. 198–213.
- [35] W. L. BIRCHER AND L. K. JOHN, *Complete system power estimation using processor performance events*, *IEEE Transactions on Computers*, 61 (2012), pp. 563–577.
- [36] R. BERTRAN, *A systematic methodology to generate decomposable and responsive power models for CMPs*, *IEEE Transactions on Computers*, 62 (2013), 7, pp. 1289–1302.
- [37] J. KONC AND D. JANEŽIČ, *An improved branch and bound algorithm for the maximum clique problem*, *Match*, 58 (2007), pp. 569–590.
- [38] D. J. JOHNSON AND M. A. TRICK, eds., *Cliques, Coloring, and Satisfiability: Second DIMACS Implementation Challenge, Workshop, October 11-13, 1993*, American Mathematical Society, Boston, MA, USA, 1996.

- [39] J. MICHALAKES, S. CHEN, J. DUDHIA, L. HART, J. KLEMP, J. MIDDLECOFF, AND W. SKAMAROCK, *Development of a Next Generation Regional Weather Research and Forecast Model*, in *Developments in Teracomputing: Proceedings of the Ninth ECMWF Workshop on the Use of High Performance Computing in Meteorology*, 2001, pp. 269–276.
- [40] J. MICHALAKES, J. DUDHIA, D. GILL, T. HENDERSON, J. KLEMP, W. SKAMAROCK, AND W. WANG, *The Weather Research and Forecast Model: Software Architecture and Performance*, in *Proceedings of the Eleventh ECMWF Workshop on the Use of High Performance Computing in Meteorology*, World Scientific, 2005, pp. 156–168.
- [41] G. KOSEC, M. DEPOLLI, A. RASHKOVSKA, AND R. TROBEC, *Super Linear Speedup in a Local Parallel Meshless Solution of Thermo-fluid Problems*, *Comput. Struct.*, 133 (2014), pp. 30–38.
- [42] *Likwid*. <https://github.com/rrze-likwid/likwid>, 2015.

*Edited by:* Dana Petcu

*Received:* July 15, 2015

*Accepted:* September 30, 2015



## AN ENERGY-AWARE ALGORITHM FOR LARGE SCALE FORAGING SYSTEMS

OUARDA ZEDADRA\*, HAMID SERIDI† NICOLAS JOUANDEAU‡ AND GIANCARLO FORTINO§

**Abstract.** The foraging task is one of the canonical testbeds for cooperative robotics, in which a collection of coordinated robots have to find and transport one or more objects to one or more specific storage points. Swarm robotics has been widely considered in such situations, due to its strengths such as robustness, simplicity and scalability. Typical multi-robot foraging systems currently consider tens to hundreds of agents. This paper presents a new algorithm called Energy-aware Cooperative Switching Algorithm for Foraging (EC-SAF) that manages thousands of robots. We investigate therefore the scalability of EC-SAF algorithm and the parameters that can affect energy efficiency overtime. Results indicate that EC-SAF is scalable and effective in reducing swarm energy consumption compared to an energy-aware version of the reference well-known c-marking algorithm (Ec-marking).

**Key words:** Swarm intelligence, swarm robotics, multi-agent foraging, energy awareness, energy efficiency.

**AMS subject classifications.** 68W05

**1. Introduction.** Swarm Intelligence comes from biological insights related to the capabilities that social insects possess to solve daily-life problems within their colonies [1]. Social insects (ants, bees, termites) provide complex collective behavior to accomplish complex tasks that can exceed individual capacities [2]. They usually lack sophisticated communication capabilities as well as sensor information [3], in opposite to intelligent and proactive individuals which are provided with sophisticated communication tools and sensors [7]. Inspirations from these biological systems known as pheromone-based coordination mechanisms have been presented for patrolling [8], localization [9] and mapping and exploration [10]. Swarm robotic is interested in the implementation of systems which are composed of thousands simple robots rather than one single complex robot [11] [12]. The simplicity of these individuals presents a highly structured social organization which can accomplish complex tasks that in far exceed the individual capacities of a single individual [13] [14]. The collection carries out complex tasks based on simple rules, without spending much computational power and much energy [15]. Behavior-based algorithms have been developed to manage homogeneously swarms of individuals and to achieve more complex tasks that can involve dynamic hierarchies [16] [17].

Foraging is a benchmark problem widely studied by swarm robotics: it is a complex task involving the coordination of several sub-tasks including efficient exploration, physical collection, transport, homing and depositing [18]. Foraging can be achieved by one single robot or by a collection of cooperative robots. By contrast, some animals are foraging individually for food [19] [20]; while others (as social insects) are foraging and recruiting collaborators by sharing information via stigmergy [21] [22] or direct signalling [23] [3]. In a foraging task, robots repeatedly collect objects from unknown locations and drop them of at another location. To work for long periods, they must have a means of obtaining more energy when their stored energy is exhausted. Time spent in searching, homing, recharging and returning to work can contain useless additional time and a current challenge in multi-robot foraging is to minimize it.

We investigate in this paper the energy problem within multi-agent foraging task through the analysis of our energy-aware algorithm (EC-SAF algorithm [4]). We tested it in large-scale foraging systems with hundreds and thousands of agents where we consider a wider range of system sizes than the ones considered in literature works and in our previous work [4]. In comparison to the literature works, we contributed at:(1) reducing the time spent in search by using our search algorithm (Stigmergic Multi-Ant Search Area algorithm–S-MASA [5]) which provides large dispersion, thus quick search and shortest paths relaying food to nest location for homing, (2) reducing the time needed for transporting food by allowing recruitment to found food defined in our previous foraging algorithm (*C-SAF algorithm* [6]).

The remainder of the paper is organized as follows: background works are presented in Section 2. Then

\*LabSTIC, 8 may 1945 University, P.O.Box 401, 24000 Guelma. Department of computer science Badji Mokhtar, Annaba University, P.O.Box 12, 23000 Annaba, Algeria([zedadra\\_nawel1@yahoo.fr](mailto:zedadra_nawel1@yahoo.fr)).

†LabSTIC, 8 may 1945 University, P.O.Box 401, 24000 Guelma, Algeria

‡LIASD, Paris 8 University, Saint Denis 93526, France

§DIMES, Universita' della Calabria, Via P. Bucci, cubo 41c - 87036 - Rende (CS) - Italy

EC-SAF and Ec-marking algorithms are presented in Section 3. In Section 4, we define the performance indices, describe simulation scenarios and compare the results of the two algorithms. Finally, Section 5 concludes the paper and shows some future works.

**2. Background.** The most common strategies for powering long-lived autonomous robots are capturing ambient energy and managing energy from recharging stations.

Capturing ambient energy directly from the environment, also known as energy scavenging [24]. A robot have to choose between searching and resting to conserve some energy and it accumulates some units of energy for each retrieved food. Krieger and Billeter [25] adopt a threshold-based approach to allocate foraging or resting tasks. They distinguish nest and robots energies. If nest energy is under a predefined threshold, then robots search for food. If one robot energy is under a predefined threshold, then it stays in the nest to recharge. Labella et al. [26] propose an adaptive approach to change the ratio of foragers to resters by adjusting the probability of leaving home. Liu et al. [27] consider collisions and object retrieval. The successes are accounted for individuals and teams in [26]. Efficient foraging is a special case, in which several types of objects, each provides a specific amount of energy are scattered in the environment and robots should choose between transporting a found food or continue searching for another that provides more energy. In [28] authors design a mathematical model of multi-foraging that predicts with a good confidence the optimal behavior of the robots that leads to maximize the energy of the group.

Transferring energy from a recharging station. Several options are possible in this case: (i) Working robots perform their work until their energy falls below a given threshold. At this time, they return to recharging station. Such decision can also be achieved with a behavior model [3]. While in [29], authors propose a distributed behavioral model for foraging regarding role division and search space division for improving energy efficiency; (ii) Working robots can stay at the working site permanently, while special dock robots visit them periodically to provide them with energy. In [30], a dock station is an autonomous robot with unlimited energy store, that searches gradually to improve its position regarding the position of working robots. In [31], the on-board recharging electronics and intelligent docking stations enable the robots to perform autonomous recharging; and (iii) Robots could transfer the energy also between them by comparing their energy's level. Robots could transfer the energy between each other in a trophallaxis-like manner, where robots with higher energy status can share energy with others having lower energy status [32].

In the following subsections, we present the background works for the energy-aware algorithms proposed in this paper: *S-MASA algorithm* [5], *C-SAF algorithm* [6] and *c-marking algorithm* [33] (Section 2.1, Section 2.2 and Section 2.3 respectively).

**2.1. S-MASA Algorithm.** The S-MASA algorithm is an exploration strategy inspired by the behavior of ants and water vortex dynamics. It was first applied to multi-target search and coverage tasks [5], and to multi-agent foraging tasks in [34] [6]. Using S-MASA algorithm as a search strategy has contributed to: (1) speed up the exploration by avoiding the already visited cells (cells containing pheromone), and (2) speed up the homing process, because optimal paths are simultaneously built while agents explore their environment (a wavefront of pheromone concentration is created). According to the coordination rules of S-MASA algorithm in Fig. 2.1, the agent changes its heading if there is no pheromone in its right cell (cell not yet visited), else it keeps going in the current heading.

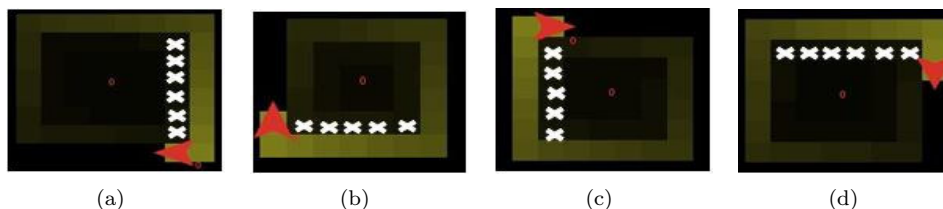

FIG. 2.1. *S-MASA coordination principle represents the changing headings: (a) from 180 to 270 (b) from 270 to 0 (c) from 0 to 90 (d) from 90 to 180, where white crosses represent already visited cells*

**2.2. C-SAF Algorithm.** C-SAF algorithm [6] is a multi-agent foraging algorithm that uses S-MASA as search strategy. Agents in C-SAF algorithm use a three layered subsumption architecture [35] where each layer implements a particular behavior: *Environment exploration* is the lowest priority layer in this architecture. It consists in exploring the environment, therefore, it includes the states *Choose-Next-Patch* and *Look-for-Food*. *Food exploitation* consists in exploiting food when it is found, it envelops the states *Pick-Food*, *Return-to-Nest*, *Return-and-Color*, *At-Home*, *Climb* and *Remove-Trail*. *Obstacle avoidance* is the higher priority layer, it implements the obstacle avoidance behavior. Higher priority layers are able to subsume lower levels in order to create viable behavior (see Fig. 2.2 for an illustration of the architecture). The behavioral model of the C-SAF foraging agents is depicted by Fig. 2.3, without the bold guards and the dashed transitions.

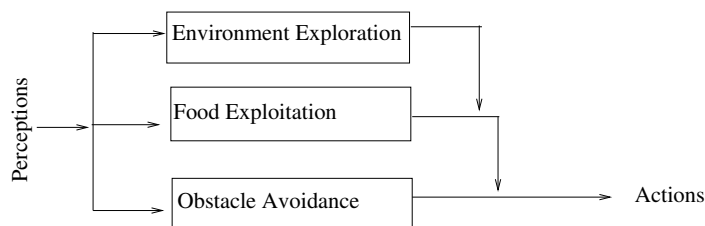

FIG. 2.2. Subsumption architecture of C-SAF foraging agents

**2.3. The c-marking Foraging Algorithm.** The c-marking foraging algorithm is a distributed parameter-free algorithm for multi-agent foraging [33]. It is a distributed and asynchronous version of wavefront algorithm [36]. It allows agents to build non optimal paths simultaneously while exploring by computing a wavefront expansion from the base station (sink). Agents use this wavefront to return to the sink. They move at each step to the cell with the smallest Artificial Potential Field (APF) value. Pseudo random walk is used by agents as a search strategy. Agents try to move to a non neighboring marked cell. If all neighboring cells are marked, then they move randomly. Unfortunately, the convergence of APF to its optimal values takes huge time. Agents therefore need to visit the same cell several times. The c-marking foraging algorithm have multiple advantages: (1) agents build simultaneously paths when they explore and (2) it is very robust to agents' failure and to complex environments. However, it provides some drawbacks: (1) paths are of long length specially when the number of agents is not sufficient to sustain the cells corresponding to the wavefront, this will increase dramatically the foraging time, (2) revisiting already visited cells in static environments costs in number of steps. The behavioral model of the c-marking foraging agents is depicted by Fig. 2.4, without the filled state, bold guards and the transitions (dashed arrows).

**3. An Energy-aware Multi-Agent Foraging Algorithm.** In this Section, we present the EC-SAF (Energy-aware Cooperative Switching Algorithm for Foraging) algorithm. Specifically, we model the behavior of foraging agents as a finite state machine. We also present the Ec-marking algorithm, which is an energy-aware version of the well-known c-marking algorithm [33]. EC-SAF and Ec-marking will be compared through simulations in Section 4.

**3.1. Modeling of the Components.** The components of the two multi-agent systems (environment, agent and pheromone) were modeled as in below:

- *Environment Model:* The search space is an  $N \times N$  grid world with several food locations, one or multiple sinks (nest), obstacles and pheromone markings. It is divided into equal squares in a Cartesian coordinate system. Grid maps are thought to an efficient metric for navigation in large-scale. In robotics, it is often used for solving tasks like path planning [37], localization [38] and search and surveillance in dynamic environments [39]. It is efficient that the full grid is square and all cells are the same size of an agent.  $N$  food with  $M$  items (we refer to it as concentration) are located randomly on grids. Obstacles with rectangular or square shapes take place on some fixed cells, the nest is at the center (in a multi-sink space, sinks take specific positions to guarantee the completeness of the algorithms).
- *Agent Model:* All agents of the colony are homogeneous with limited sensing and actuation capabilities. They start all from a predefined position (the nest) and headings (0, 90, 180 and 270). An agent can

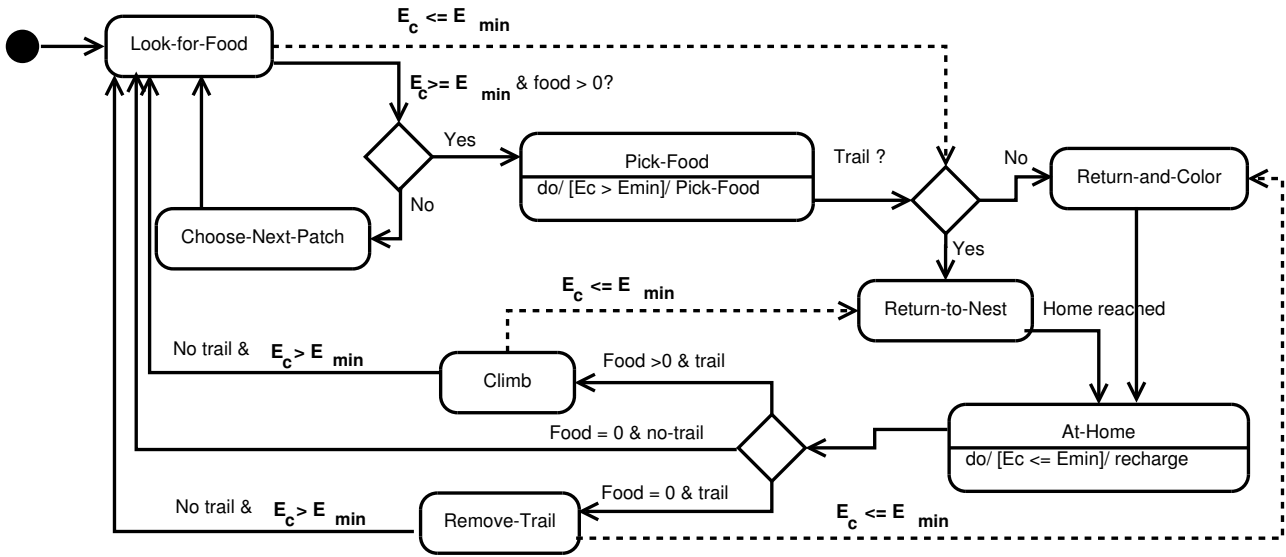

FIG. 2.3. the state machine of a foraging agent. Dashed arrows (transitions), bold guards and the internal actions in the states represent the energy-aware behavior of agents

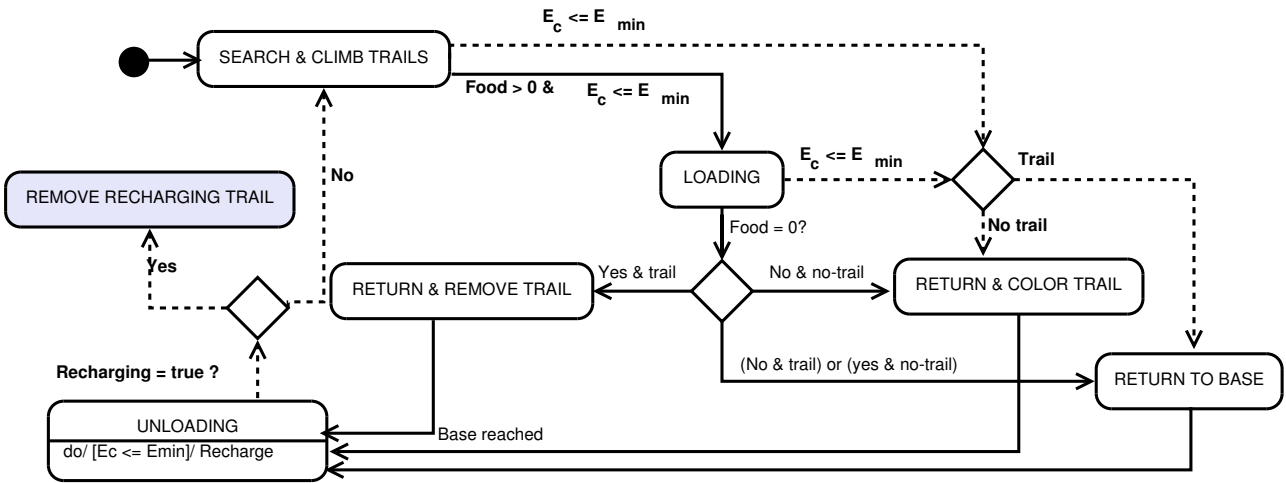

FIG. 2.4. State transition diagram of an  $E_c$ -marking agent, where colored state, dashed arrows (transitions) and bold guards are related to energy-aware behavior of agents

carry out the following sequence of actions:

- Senses whether a food item exists on the current cell and if there exists a pheromone in the four neighboring cells, whether it is at the nest, and it recognized whether it is carrying food or not.
  - Deposits a limited amount of pheromone in the current cell.
  - Picks up (loads) or puts down (unloads) a food item, when it is at food and carries no food, and when it is at nest and carrying food respectively.
  - Selects and carries out actions according to the surrounding events. The agent have four different behaviors corresponding to the four models (C-SAF, c-marking, EC-SAF and  $E_c$ -marking) and the set of actions to execute differ from a model to another.
- *Pheromone Releasing and Evaporation:* The agent is able to secrete several types of pheromone, which

did not affect each other, at the same cell in the environment. Each forager is capable of depositing three types of pheromone. The first type, is dynamic and subsequently gradually evaporates (according to Eq. 3.1), used to mark already visited cells. The two others, are static with no diffusion and evaporation properties, one is used to keep track of the food location (food trails in yellow color) and the other to attract other agents to food locations (recruitment trails in brown color).

$$\Gamma_i(t+1) = \gamma_i(t) - p * \gamma_i(t) \quad (3.1)$$

where  $p$  is a coefficient which represents the evaporation rate of trail between time  $t$  and  $(t+1)$ .

**3.2. EC-SAF Algorithm.** The EC-SAF algorithm extends the C-SAF algorithm [6] to consider energy limitation in a foraging system, where agents use the existing set of states (equivalent to return and color / remove trails) with some additional transitions and guards. We added a layer in the previous subsumption architecture (Fig. 2.2), called *Recharging energy* layer which envelops the set of states that allow agents to return home to recharge when their energy falls below a given threshold, it includes the states *Return-to-Nest*, *Return-and-Color*, *Remove-Trail* and *At-Home* (see Fig. 3.1 for the subsumption architecture with the new layer). The behavior of our energy-aware foraging agents is shown by the state machine in Fig. 2.3 where dashed arrows (transitions), bold guards and actions in the states are used when the current energy of an agent ( $E_c$ ) falls below the fixed threshold ( $E_{min}$ ). States are described below and the EC-SAF Algorithm is given by Algorithm 1.

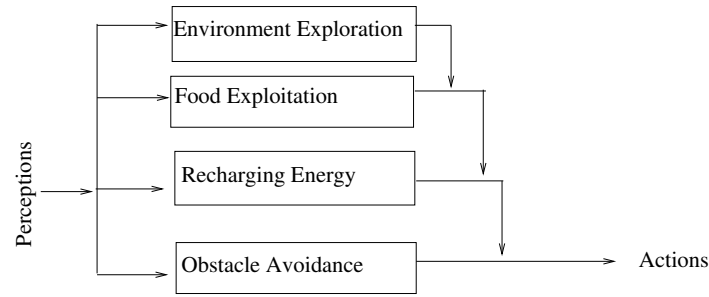

FIG. 3.1. Subsumption architecture of EC-SAF foraging agents

**Look-for-Food:** If  $E_c > E_{min}$  and there exists a food here, agent executes *Pick-Food* state, while if there exists no food it executes *Choose-Next-Patch* state. If there exists a trail and its  $E_c \leq E_{min}$ , it turns to *Return-to-Nest* state, or to *Return-and-Color* state, if there exists no trail.

**Choose-Next-Patch:** If an obstacle is detected, the agent calls the procedure *Avoid-Obstacle()*. If no obstacle is there, the agent climbs the brown trail to reach the food location if there exists one, it spreads then the information to its left cell. It lays a limited amount of pheromone in current cell, adjusts its heading by executing S-MASA Algorithm [5] and moves one step forward. It turns automatically when finished to *Look-for-Food* state.

**Pick-Food:** If  $E_c > E_{min}$ , agent picks a given amount of food and spreads the information to its left cell. However, if  $E_c \leq E_{min}$  it does not pick food. It executes in the two cases *Return-to-Nest* state, if there exists a trail or *Return-and-Color* state if there exists no trail.

**Return-to-Nest:** The agent moves to one of colored neighboring cells with the lowest pheromone value. It remains in this state until home is reached, it turns then to *At-Home* state. ;

**Return-and-Color:** The agent moves to one of the four neighboring cells with the lowest pheromone value and marks its trail with yellow and remains in this state until it reaches the home; it turns then to the *At-Home* state.

**At-Home:** The agent unloads food if it carries one. If its current energy ( $E_c$ ) is below ( $E_{min}$ ), it recharges its energy to the maximum amount  $E_{max}$ . It goes to *Climb* state if there exists a trail and the amount of food is  $> 0$ . If amount of food is  $= 0$  and there is a trail, it executes *Remove-Trail* state, else it turns to *Look-for-Food* state.

**Look-for-Food**

```

if ( $E_c \leq E_{min}$ ) then
  | if ( $\exists$  trail) then goto Return-to-Nest;
  | else goto Return-and-Color;
else
  | if ( $food > 0$ ) then Diffuse(P); goto Pick-Food;
  | else goto Choose-Next-Patch;

```

**Choose-Next-Patch**

```

if (obstacle detected) then Avoid-Obstacle();
else
  | if (brown P here) and (brown P in right cell) then
  | | Diffuse(P); move to food location using brown cells;
  | else
  | | if (brown P here) and (no brown P in right cell) then
  | | | remove brown trail;
  | | else
  | | | Lay(P); Detect-And-Adjust-Heading() Update(P); Move();
  | goto Look-for-Food;

```

**Pick-Food**

```

if ( $E_c > E_{min}$ ) then pick up a given amount of food; Diffuse(P);
if ( $\exists$  trail) then goto Return-to-Nest;
else goto Return-and-Color;

```

**Return-to-Nest**

```

while home not reached do
  | move to a colored neighboring cell with the lowest  $P$ ;
goto AT-HOME;

```

**Return-and-Color**

```

while home not reached do
  | move to a neighboring cell with the lowest  $P$  Color that cell to a specific trail color (yellow);
goto At-Home

```

**At-Home**

```

unload food if ( $E_c \leq E_{min}$ ) then recharge  $E_c$  to  $E_{max}$ ;
if ( $\exists$  trail and  $food > 0$ ) then goto Climb;
else if ( $\exists$  trail and  $food = 0$ ) then goto Remove-Trail;
else goto Look-for-Food;

```

**Climb**

```

while  $\exists$  trail do
  | if ( $E_c \leq E_{min}$ ) then goto Return-to-Nest;
  | else move to neighboring colored cell with the greater value of  $P$ ;
goto Look-for-Food;

```

**Remove-Trail**

```

while  $\exists$  trail do
  | if ( $E_c \leq E_{min}$ ) then goto Return-and-Color;
  | else move to neighboring colored cell with the greater value of  $P$  and update its color to the default one (black);
goto Look-for-Food;

```

**Algorithm 1:** EC-SAF Algorithm, where pheromone is noted  $P$



**Climb:** Agent moves to one of its four colored neighbors with a pheromone value greater than the pheromone value of the current cell. It remains in this state until no colored cell (yellow trail) exists and its  $E_c > E_{min}$ , it turns then to the *Look-for-Food* state. If its  $E_c \leq E_{min}$  and since there exists a trail, it executes the *Return-to-Nest* state in order to return home for recharging its energy.

**Remove-Trail:** The agent moves to a colored cell with the greatest pheromone value and resets its color to the default color (black). It remains in this state until no colored cell is found and  $E_c > E_{min}$ , it turns then to the *Look-for-Food* state. If  $E_c \leq E_{min}$ , the agent returns to home to recharge and executes the *Return-and-Color* state since it already removed the existing trail and to keep track of the last position from where it will continue removing after it recharges its energy.

**3.3. Ec-marking Algorithm.** The Ec-marking algorithm extends the c-marking algorithm [33] to deal with energy limitation. Ec-marking agents behavior is given by Fig. 2.4 (the extensions made are represented by filled states, dashed transitions and bold guards), while using the rules in Algorithm 2. Agents while exploring the environment build simultaneously paths between food and nest which results in building an ascending Artificial Potential Field (APF) incrementally [33]. Agents use pseudo random walk as search strategy, which results in non-optimal paths and makes the convergence of the APF to its optimal value very slow. We use the same set of states as in c-marking to return home for recharging (states corresponding to return and color or return to base), while for removing the energy trails, we define a new state called *REMOVE RECHARGING TRAIL*. This last state is activated when agents finish recharging their energy from home, they climb then the trail and remove until there is no trail, they resume then their search process.

**4. Performance Evaluation.** In this Section, we discuss the performance of the four algorithms (EC-SAF [Algorithm 1], C-SAF [6], c-marking [33] and Ec-marking [Algorithm 2]) in obstacle-free and obstacle environments. We present in Section 4.1 the performance indices and simulation parameters used to evaluate the algorithms. On the basis of analysis of an execution example for the four algorithms in Section 4.2, we compared only E-C-SAF and Ec-marking algorithms in Section 4.4, we describe the scenarios used for simulations in Section 4.3.

In each simulation several parameters are to be set:

- Agent parameters: the number of agents that participate at each simulation (*agent number*) and the amount of food (in units) that an agent can transport at each time (*agent capacity*).
- World parameters: include the dimension of the search space which is a grid of  $N \times N$  cells (*world size*). *World complexity* which can be obstacle-free or obstacle environment. *Sink number* which is the number of the home or base stations to where agents return food and recharge energy.
- Food parameters: the number of food locations (*food density*) which are located at fixed positions. Each food location contains a limited amount of food called *food concentration*.
- $E_{max}$ : is the maximum value that an agent can recharge when it reaches home and its  $E_c$  is below the threshold  $E_{min}$ . An analysis of the effect of different  $E_{max}$  on overall search time and the total energy consumed in EC-SAF algorithm is given in Table 4.1. When  $E_{max}$  is set to smaller value (1000 and 3000 units) agents return home several times to recharge (18 to 5 times), increasing the search time and the energy consumed, thus the search becomes inefficient. It is set to 5000 energy units, since number of returns to recharge is small (2 times) thus doesn't consume much energy and search time.
- $E_c$ : represents the current energy that an agent have at time ( $t$ ). It is set initially to  $E_{max}$  that is 5000 energy units. When  $E_c \leq E_{min}$ , agents need to return home to recharge energy.
- $E_{min}$ : is the threshold that activates the return to home and recharge energy behaviors. It is fixed experimentally to a value that allows agents to get home before their death ( $E_c = 0$ ) (Table 4.2). With 100 units, agents can't reach home because the path is longer and needs more energy units. When we increased  $E_{min}$  to 200 units, agents could reach the home the first return, but in the second return they couldn't reach it. We increased then energy to 300 units and it was sufficient to return home for 2 times to recharge (and food is reached in this stage). The pseudo random walk in Ec-marking makes the measuring of the  $E_{min}$  very difficult, sometimes food is rapidly located and paths are close to optimal, thus the 300 energy units are sufficient to return home to recharge, but in other cases, paths are not optimal and agents need more than 300 energy units to reach home. To deal with such cases, we fixed the  $E_{min}$  to 500 units.

```

SEARCH & CLIMB TRAIL(Repeat)
if ( $E_c \leq E_{min}$ ) then
  if ( $\exists$  trail) then goto RETURN TO BASE;
  else goto RETURN & COLOR TRAIL;
else
  if (food exist in neighboring cell) then
    move into that cell; goto LOADING;
  else
    if ( $\exists$  trail) then
      move to the highest valued colored neighboring cell;
    else goto EXPLORATION & APF CONSTRUCTION;

LOADING
if ( $E_c \leq E_{min}$ ) then
  if ( $\exists$  trail) then goto RETURN TO BASE;
  else goto RETURN & COLOR TRAIL;
else
  Pick up a quantity  $Q_{max}$  of food;
  if (food is not exhausted) then
    if ( $\exists$  trail) then goto RETURN TO BASE;
    else goto RETURN & COLOR TRAIL;
  else goto RETURN-AND-REMOVE-TRAIL;

RETURN & COLOR TRAIL
color the cell in a specific color and update value;
if (base reached) then goto UNLOADING;
else move to a neighboring cell with the smallest APF value;

RETURN & REMOVE TRAIL
if (cell has the trail color) then remove this color and UPDATE VALUE;
if (base is reached) then goto UNLOADING;
if (there exists a neighboring cell with trail color) then
  move to neighboring trail cell;
else move to the smallest valued neighboring cell;

UNLOADING
unload food;
if ( $E_c \leq E_{min}$ ) then recharge a limited amount of energy;
if (recharging = true) then goto REMOVE RECHARGING TRAIL;
else goto SEARCH & CLIMB TRAIL;

REMOVE RECHARGING TRAIL
while  $\exists$  trail do
  if ( $E_c \leq E_{min}$ ) then goto RETURN & COLOR;
  else move to neighboring colored cell with the highest APF value;
goto SEARCH & CLIMB TRAIL;

```

Algorithm 2: Ec-marking Algorithm

**4.1. Performance Indices and Simulation Parameters.** We analyze in this Section the performances of the two algorithms in large-scale systems within the foraging task. We used therefore, large number of agents and large environment sizes with the aim to: (1) test and conclude the benefit of providing agents with energy-

TABLE 4.1  
*E<sub>max</sub> Analysis*

	1000	3000	5000	7000	9000
Search time	7761,4	5771,3	2530,1	2231,4	2030,1
Energy Consumed	12475	10550	10125	9935	6095
Number of returns	18	5	2	1	0

TABLE 4.2  
*E<sub>min</sub> Analysis*

	100	200	300	400	500
Number of returns	0	1	2	2	2
Success to get home?	No	No	Yes	Yes	Yes

aware behaviors to sense and manage their energy, thus go to an energy-aware version of the C-SAF algorithm, (2) test the efficiency of the proposed algorithm through the total amount of energy consumption regarding the amount of food foraged, and (3) observe the evolution of energy consumed by the swarm overtime. We used the performance indices *Total Food Returned*, *Energy Efficiency* [29], *Energy Efficiency overtime*, *Total Energy Consumed* and *Finish foraging time*.

- **Total Food Returned:** is the total amount of food (in units) returned over a given elapsed time.
- **Total Energy Consumed:** is the total energy spent by all agents to search and exhaust all the food locations.
- **Energy Efficiency:** is the average energy consumed for foraging food. It is calculated according to Eq. 4.1. Since the *Total Energy Consumed* increases with the time, if  $E_{eff1} > E_{eff2}$ , it means that  $E_{eff2}$  is better.

$$E_{eff} = \frac{TotalEnergyConsumed}{TotalFoodReturned} \quad (4.1)$$

- **Energy Efficiency Overtime:** is the average energy consumed until time  $t$  to forage an amount of food units until time  $t$ . It is calculated according to Eq. 4.2.

$$E_{eff}(t) = \frac{TotalEnergyConsumed(t)}{TotalFoodReturned(t)} \quad (4.2)$$

where:  $TotalEnergyConsumed(t)$  is the total energy consumed until a given elapsed time  $t$  [0..t] and  $TotalFoodReturned(t)$  is the number of food Foraged until a given elapsed time  $t$  [0..t].

- **Finish foraging time ( $T_{forag}$ ):** The amount of time in seconds needed to finish the foraging mission. It is when all the food sites are discovered and exhausted.

The energy consumption of an agent at each state is defined as estimation of the power of real robot equipment (such as motor, sensor and processor) required to achieve that state. It is inspired by the B-swarm model [3]. The energy consumption settings of a robot are described in Table 4.3 for the two energy-aware algorithms.

**4.2. Example of Simulation Execution.** C-SAF agents have limited energy but no recharging ability, so after their energy stores are empty they die while EC-SAF agents have limited energy and recharging behaviors, that allow them to work for long time. Simulation is based on Netlogo [40]. We used a preliminary scenario to test the benefit of providing agents with energy-aware behaviors when they have limited energy stores. We used environments with a 1000x1000 cells with: one sink at the center, one food location that contains 500 units of food, to exclude the impact of food position, the food is placed at fixed position for all simulations; 300 agents with a capacity of transport of one unit at each time. We calculated the total amount of food returned

TABLE 4.3  
The agent energy consumption of each state

States	Energy consumed (unit/simulation update)
<b>EC-SAF States</b>	
At-Home, Choose-Next-Patch, Pick-Food,	5
Remove-Trail, Return-and-Color	0
Climb, Return-to-Nest	1
Avoid-Obstacle	3
<b>Ec-marking States</b>	
SEARCH, LOADING, UNLOADING,	5
RETURN & REMOVE TRAIL	0
RETURN & COLOR TRAIL	0
REMOVE RECHARGING TRAIL	0
CLIMB TRAIL, RETURN TO BASE	1
Avoid-Obstacle	3

until the completion foraging time for the algorithm that takes the longest time (Ec-markings algorithms). The obtained results with the four algorithms (C-SAF, EC-SAF, c-marking and Ec-marking) are depicted by Fig. 4.1, where we limited the energy stores in C-SAF and c-marking to 2000 units and the  $E_{min}$  to 500 units. From Fig. 4.1, we observe that the total food returned increases overtime in the four algorithms when agents have enough energy. However, when the agent energy is over in algorithms C-SAF and c-marking, agents die and there will be no changes in *Total Food Returned*. While in EC-SAF and Ec-marking, they return home after their energy fall below  $E_{min}$ , recharge and resume their tasks. EC-SAF reaches the total amount of food at 1600 seconds (2100 seconds in obstacle environment), thus it stops search, while Ec-marking reaches it at 2300 seconds (3300 seconds in obstacle environment). Agents spend more time and consume more energy, specially in c-marking algorithms since paths are not optimal, while in EC-SAF agents use optimal paths, which contributes at reducing the recharging the overall and the energy consumed.

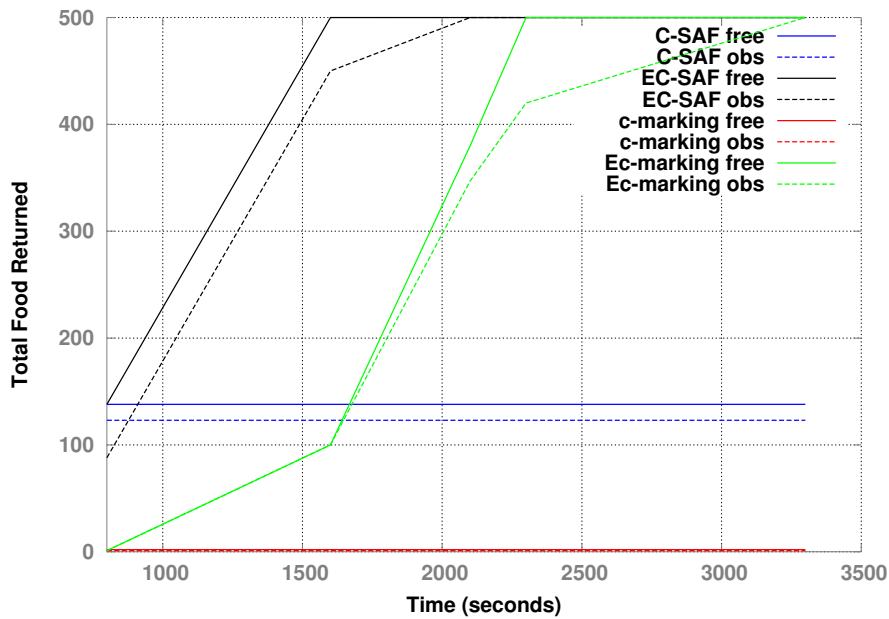

FIG. 4.1. Total Food Returned by EC-SAF, C-SAF, Ec-marking and c-marking agents until the finish foraging time in obstacle-free and obstacle environments

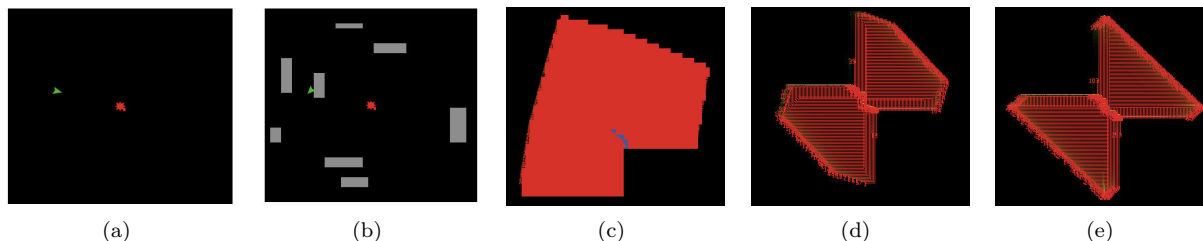

FIG. 4.2. World setups used in simulations. (a) obstacle-free environment, (b) obstacle environment, where red arrows are agents, green arrows are food locations, gray blocks are obstacles and pink squares are sinks. (c)(d)(e) present samples at different stages where laden agents are in the middle line, and searcher agents spread themselves diagonally on sides.

TABLE 4.4  
Parameters of scenario 1, scenario 2 and scenario 3

Parameter		Value
<b>Scenario 1</b>	<i>E<sub>eff</sub></i> Analysis	
World size		100x100 cells – 1000x1000 cells
Number of agents		100 – 1000 agent
Food density		1 – 10 locations
Food concentration		500 units
Agent capacity		1 unit
Sinks number		1 – 64 sink
<b>Scenario 2</b>	<i>Total Energy Consumed Analysis</i>	
World size		1000x1000 cells
Number of agents		300 agent
Food density		2 locations
Food concentration		500 units
Agent capacity		1 unit
Sinks number		1 sink
<b>Scenario 3</b>	<i>Scalability Analysis</i>	
Agent Density		0.00001– 0.01
Food density		2 location
Food concentration		400 units
Agent capacity		1–10 unit
Sinks number		1 sink

Figure 4.2 shows some of the world setups used in the three scenarios discussed above. An obstacle-free and obstacle environments with one food location and one sink at the center of world in Figs 4.2(a) and 4.2(b) respectively. While we present samples of simulation execution in obstacle-free environment with one sink and one location in Fig. 4.2(c) and with two food locations in Figs 4.2(d) and 4.2(e) where agents in the middle are transporting food and agents at the sides still searching.

**4.3. Simulation Scenarios.** Several kinds of simulations are carried out in this paper. The parameters which we tested and analyzed are reported in Table 4.4. We proposed three fundamental scenarios:

- Scenario 1 is to test which of the parameters presented in Section 4 can affect the *Energy Efficiency*. It envelops 5 sub-scenarios. Sub-scenario 1 is to show  $E_{eff}(t)$  pattern overtime. Sub-scenario 2 is to analyze the impact of *agents number* on performance, which number gives less  $E_{eff}$ . Sub-scenario 3 is to test how *world size* can affect the  $E_{eff}$  and is there any minimal size under which a number of agents can carry efficiently the foraging task. In order to analyze whether clustering the food units in

one location or distributing it over several locations improves performances, we defined sub-scenario 4 where we varied *food density* from 1 to 10. To test the effect of dividing the environment into smaller search spaces, we defined sub-scenario 5, in which we varied number of sinks from 1 (one search space) to 64.

- Scenario 2 is defined to show the *Total Energy Consumed* by the swarm of agents over the foraging task.
- Scenario 3 is defined to study the scalability of our algorithm and whether varying the *agent density* affects positively or negatively the  $E_{eff}$ . We used three sub-scenarios. Where we define in each one *Agent Density* as *Number of Agents / World Size*. In the first sub-scenario, we kept the *agent density* fixed to a given value while varying *agents number* and *world size* simultaneously. In the second, we increase the *agent density* by keeping *agents number* fixed and increasing *world size*. In the third, we decrease the *agent density* by increasing the *agents number* and keeping *world size* fixed.

#### 4.4. Results Analysis.

**4.4.1. Results in Scenario 1.** Results in Fig. 4.3 show a decrease in  $E_{eff}(t)$  in the two algorithms. In EC-SAF, when agents search and depose pheromone, they consume more energy, but when food is located the amount of food returned increases, thus the ratio decreases. However, in Ec-marking, the  $E_{eff}(t)$  is high because of the pseudo random walk which slows the search process, after the food is located,  $E_{eff}(t)$  decreases dramatically overtime since the amount of food returned increases. Results obtained with EC-SAF (also with Ec-marking) in obstacle-free and obstacle environment are very close and their curves overlap in Fig. 4.4.

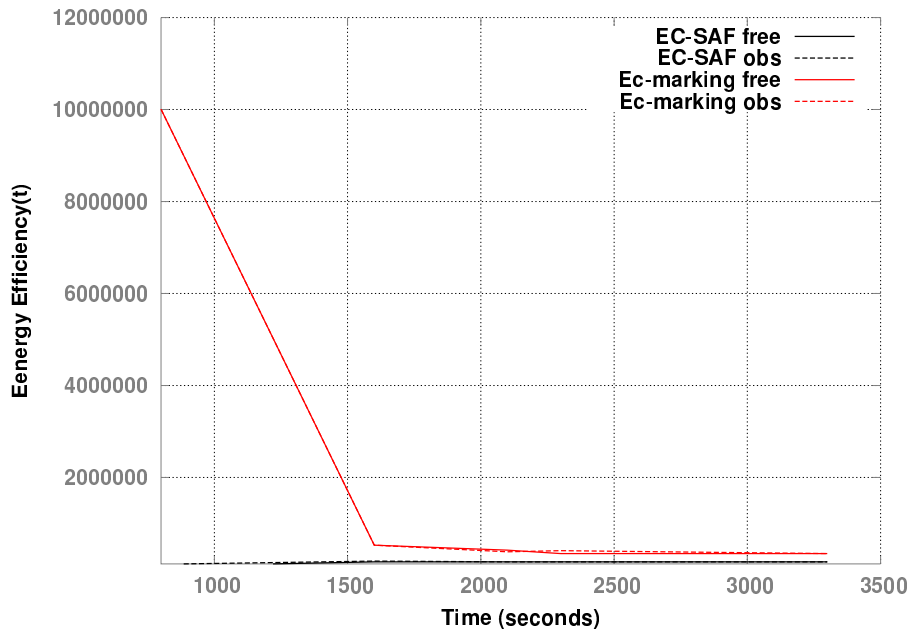

FIG. 4.3. Variation of  $E_{eff}(t)$  overtime

Figure 4.4(a) shows the results obtained by EC-SAF and Ec-marking algorithms when varying agent number. The growth of  $E_{eff}$  in EC-SAF is constant and slow. While, in Ec-marking  $E_{eff}$  is inconstant. It increases and decreases overtime, higher with 100 agents, where they spend more time in search (finish foraging time is 9907 seconds), thus consume more energy. It is much less with 300 agents (finish foraging time 2325 seconds only). The quick search provided by S-MASA algorithm [5] in EC-SAF contributes at reducing search time, thus energy consumption and  $E_{eff}$ .

$E_{eff}$  in EC-SAF is reduced with each increase in world size. This last affects the results when it couldn't hold on the total number of agents, it means that large number of agents can reach rapidly the boundaries

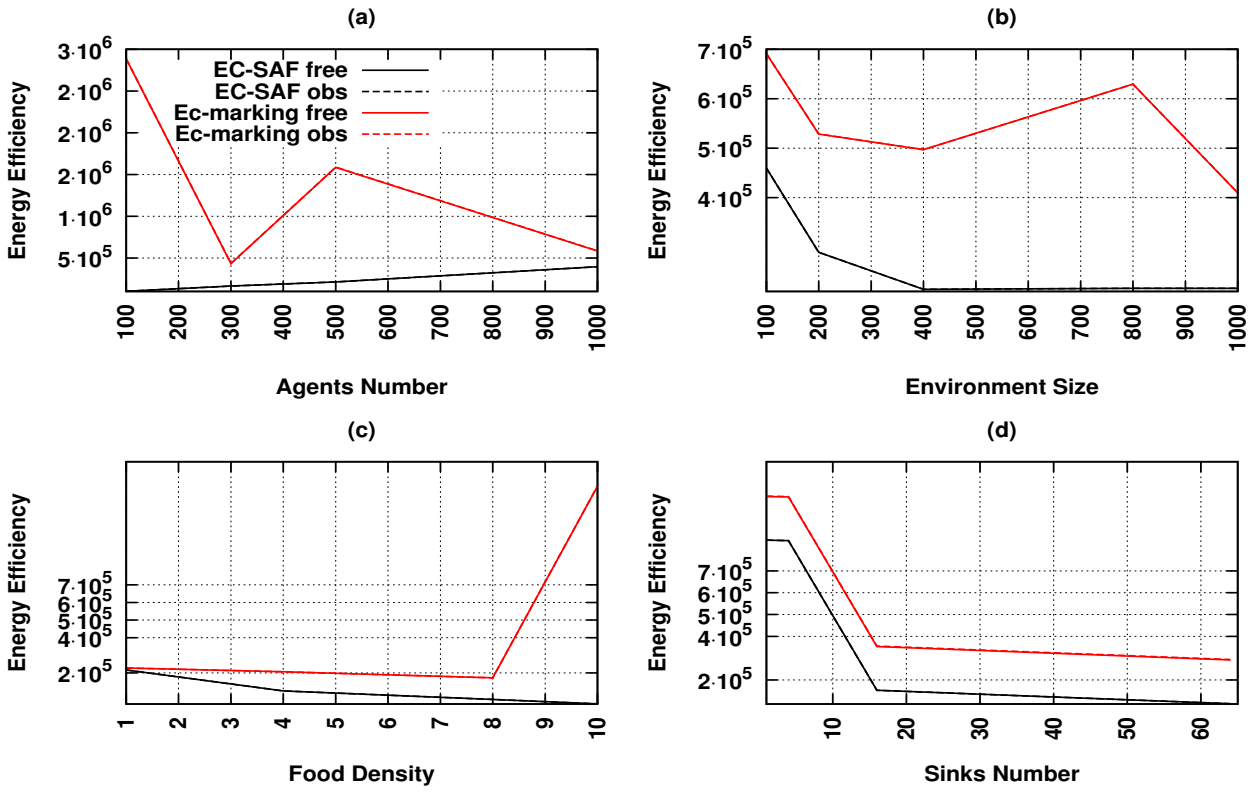

FIG. 4.4. Simulations showing  $E_{eff}$  in world with and without obstacles when varying: (a) agents number, (b) world size, (c) food density, (d) sink number. Where the legend in (a) is the same for the other Figs

(and stop search) even if food is already found. If the world size is sufficient, more agents will contribute at transporting food, increasing by the way the total amount of returned food, thus less  $E_{eff}$ . In Ec-marking, the  $E_{eff}$  changes overtime when world size is 800x800 cells it increases dramatically while it was decreasing with the other world sizes. Graphical representation of results is in Fig. 4.4(b).

Increasing food density helps in improving results in the two algorithms. It helps in increasing the amount of foraged food because at each increase in food locations, agents in EC-SAF will be divided between several locations, thus the paths to traverse are smaller and the energy consumed is lower (see Fig. 4.2(d)).  $E_{eff}$  in the two algorithms is very close when using one food location, it is because in Ec-marking the food is located quickly, but with increasing the food locations, results tend to decrease and converge from each other. They are higher in Ec-marking. Plots in Fig. 4.4(c) present the results obtained by the two algorithms in obstacle-free and obstacle environments.

In sub-scenario 5, when dividing the environment (by using several sinks rather than one), search space becomes smaller and paths shorter in both of the algorithms.  $E_{eff}$  is reduced, since energy consumption is less and returned food is more. In Ec-marking,  $E_{eff}$  is higher than EC-SAF (see Fig. 4.4(d)).

**4.4.2. Results in Scenario 2.** The growth of  $E_{eff}$  is constant overtime in both of the algorithms. In EC-SAF, *Total Energy Consumed* is less because agents avoid unnecessary moves by avoiding already visited cells, while it is higher in Ec-marking, since agents need to return to already visited cells several times in order to reach the optimal values of the Artificial Potential Field (APF) (Fig. 4.5). Since results obtained with EC-SAF in obstacle-free and obstacle environment are very close, their curves overlap in Fig. 4.5.

**4.4.3. Results in Scenario 3.** When agent density is fixed, the growth in total energy consumed is linear in EC-SAF algorithm. The foraging time increases which means more search time and more energy consumption

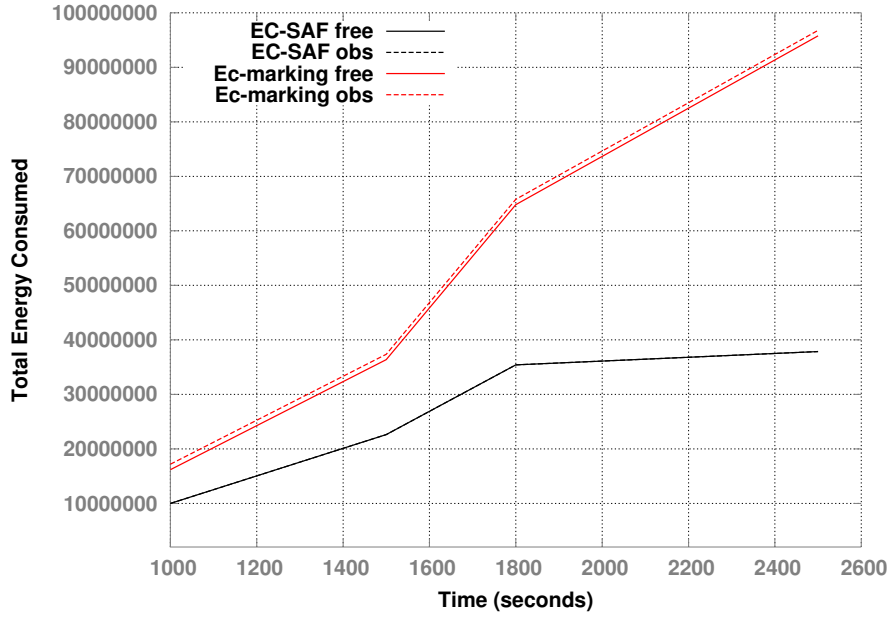

FIG. 4.5. Total Energy Consumed overtime

until agents reach the total amount of food. Varying both parameters (*agent number* and *world size*) at the same time does not affect the growth of  $E_{eff}$ . Table 4.5 and Fig. 4.6(a) present the evolution of  $E_{eff}$  in both algorithms overtime when fixing agent density. In Ec-marking, the growth  $E_{eff}$  is higher, it starts at decreasing when food is located. Also in this scenario, results obtained with EC-SAF (also with Ec-marking) in obstacle-free and obstacle environment are very close and their curves overlap in Figs. 4.6(b) and 4.6(c). The  $E_{eff}$  in Tables 4.5 and 4.6 is given in kilo.

TABLE 4.5  
Results in scenario 3 when keeping agent density fixed to 0.01

Agent density	0.01	0.01	0.01	0.01
Agent number	100	2500	3600	6400
World size	100x100	500x500	600x600	800x800
<b><math>E_{eff}</math> in obstacle-free world</b>				
EC-SAF	14	190	394	621
Ec-marking	720	8263	444643	11616
<b><math>E_{eff}</math> in obstacle world</b>				
EC-SAF	15	206	464	807
Ec-marking	758	16526	444652	20202

When decreasing agent density in sub-scenario 2,  $E_{eff}$  decrease is constant and slow in EC-SAF. When decreasing agent density, we got a very low decrease in  $E_{eff}$ , since the varying parameter is world size, which doesn't influence significantly  $E_{eff}$ . While the growth of  $E_{eff}$  is inconstant in Ec-marking, it grows in linear until the value density 0.00004, it increases dramatically to higher value, and decreases after that when density is 0.0001 (see Fig. 4.6(b)).

In sub-scenario 3, in EC-SAF more agents with smaller paths provide fast foraging time and less  $E_{eff}$ . It reaches its minimum value in 0.0001 density value, over it the increase in agent number provides long paths to traverse until food location, thus large search time and more  $E_{eff}$ . In Ec-marking, the growth in  $E_{eff}$  is constant but still very high in comparison to EC-SAF (see Fig. 4.6(c)).



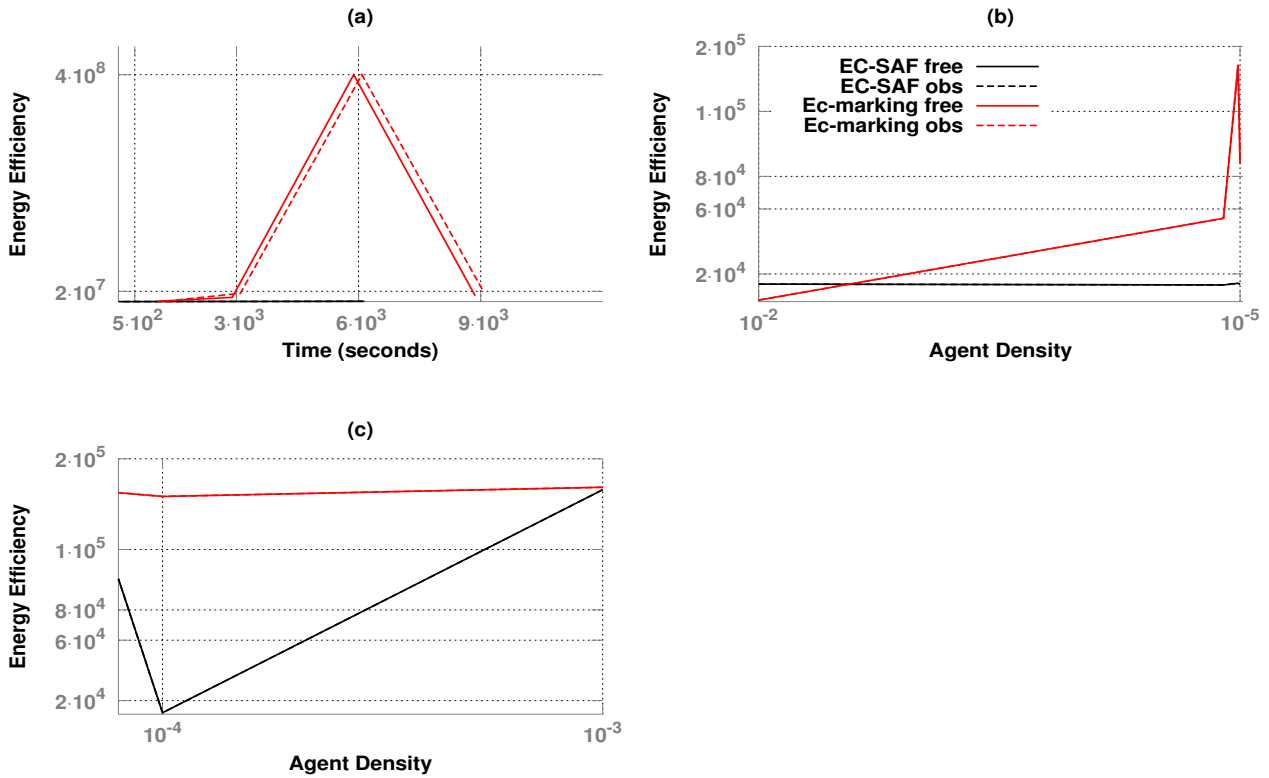

FIG. 4.6. Simulation results of scenario 3 represents the variations in  $E_{eff}$  when: (a) keeping Agent Density fixed, (b) decreasing Agent Density, (c) increasing Agent Density. Where the legend in (b) is the same for the other Figs

TABLE 4.6  
Varying Agent Density

Agent density	0,01	0,001	0,0001	0.0004	0.00001	0.00006
<b>Results without obstacle</b>						
$E_{eff}$ EC-SAF	14	159	14	13	101	14
$T_{forag}$ EC-SAF	100	4245	461	501	2943	775
$E_{eff}$ Ec-marking	4	161	149	54	158	88
$T_{forag}$ Ec-marking	453	4232	4232	794	3948	4516
<b>Results with obstacles</b>						
$E_{eff}$ EC-SAF	14	159	14	13	101	14
$T_{forag}$ EC-SAF	202	4340	565	635	3043	877
$E_{eff}$ Ec-marking	4	161	149	54	158	88
$T_{forag}$ Ec-marking	658	2023	4432	105	4184	4713

The growth of  $E_{eff}$  in EC-SAF is constant when varying *Agent Density* and inconstant in Ec-marking. The EC-SAF algorithm is scalable, and it can be used for large systems with large number of agents and large world sizes. However, it presents better results when adjusting some parameters. Table 4.6 presents the obtained results in terms of  $E_{eff}$  and  $T_{forag}$  for both of the algorithms when varying *Agent Density* in obstacle-free and obstacle environment.

**4.4.4. Summary of Results.** Varying some parameters have trivial results and doesn't need simulations such as *agent capacity* and *food concentration*. When varying *agent capacity*, we got a decrease in foraging time, a decrease in energy consumption (since agents need less visits to food) and increase in the *Total Food Returned* (since the agent capacity is increased), thus  $E_{eff}(t)$  decreases dramatically when increasing the *agent capacity*. Unfortunately, when increasing *food concentration*, agents need more visits to exhaust the food, thus more energy consumption and higher  $E_{eff}(t)$ . However, some parameters affect  $E_{eff}(t)$ ,  $E_{eff}$  and must be adjusted together in order to improve the performances. *Agent number* can limit the scalability of the proposed protocol when using it in small *world sizes* with one food location. It provides large paths to traverse by agents and reduces the number of agents participating at the transport task which results in consuming more energy and reduces the number of food returned. While dividing the environment into smaller sub-spaces provides shorter paths to food, thus less energy consumption and large amount of food returned. EC-SAF protocol allows constant growth in results when used with large number of agents and large environment sizes, however, the influencing parameters need to be adjusted together. Thus, the large number of agents should be used with more than one food location in order to reduce the length of paths and to increase recruitment of agents (to transport quickly the food) and under sufficient world size that can allow all agents to participate to transport task.

**5. Conclusion.** This paper presents a study of the energy-aware EC-SAF algorithm performances in large-scale multi-robot foraging systems. It analyzed the parameters which can affect the *Energy Efficiency*. Different scenarios were used therefore, and we conclude that the proposed algorithm is scalable and can be used with large environmental configurations. However, it is influenced by the *agent number*, *world size*, *food density* and their adjustment together provides better performances. The shortest paths and the avoiding of unnecessary moves (revisiting already visited cells) provided by S-MASA helps in giving better results than the Ec-marking algorithm that uses pseudo random walk.

In the future, we intend to explore other environment configurations and examine other possibilities to reduce the energy consumption in EC-SAF.

#### REFERENCES

- [1] N. EL. ZOGHBY, V. LOSCRI, E. NATALIZIO AND V. CHERFAOUI, *Robot cooperation and swarm intelligence*, Wireless Sensor and Robot Networks: From Topology Control to Communication Aspects, 2014, pp. 168–201.
- [2] M. DORIGO, E. BONABEAU AND G. THERAULAZ, *Ant algorithms and stigmergy*, Future Generation Computer Systems, 16 (2000), pp. 851–871.
- [3] L. PITONAKOVA, R. CROWDER AND S. BULLOCK, *Understanding the role of recruitment in collective robot foraging*, MIT Press, (2014).
- [4] O. ZEDADRA, N. JOUANDEAU, H. SERIDI AND G. FORTINO, *Energy Expenditure in Multi-Agent Foraging: An Empirical Analysis*, Proceedings of the 2015 Federated Conference on Computer Science and Information Systems (FedCSIS), 2015, pp. 1773–1778, IEEE.
- [5] O. ZEDADRA, N. JOUANDEAU, H. SERIDI AND G. FORTINO, *S-MASA: A Stigmergy Based Algorithm for Multi-Target Search*, Proceedings of the 2014 Federated Conference on Computer Science and Information Systems, Annals of Computer Science and Information Systems, 2 (2014), pp. 1477–1485.
- [6] O. ZEDADRA, N. JOUANDEAU, H. SERIDI AND G. FORTINO, *Design and Analysis of Cooperative and Non-Cooperative Stigmergy-based Models for Foraging*, Proceedings of the 19th IEEE International Conference on Computer Supported Cooperative Work in Design, 2015.
- [7] Y. ZHANG, *Observation-Based Proactive Communication in Multi-Agent Teamwork*, Scalable Computing: Practice and Experience, 8 (2007), pp. 63–77.
- [8] F. PASQUALETTI, A. FRANCHI AND F. BULLO, *On optimal cooperative patrolling*, 49th IEEE Conference on Decision and Control (CDC), 2010, pp. 7153–7158.
- [9] J. STIPES, R. HAWTHORNE, D. SCHEIDT AND D. PACIFICO, *Cooperative localization and mapping*, Proceedings of the 2006 IEEE International Conference on Networking, Sensing and Control, 2006, pp. 596–601.
- [10] A. MARJOVI, J. G. NUNES, L. MARQUES AND A. DE ALMEIDA, *Multi-robot exploration and fire searching*, IEEE/RSJ International Conference on Intelligent Robots and Systems, 2009, pp. 1929–1934.
- [11] M. BRAMBILLA, E. FERRANTE, M. BIRATTARI AND M. DORIGO, *Swarm robotics: a review from the swarm engineering perspective*, Swarm Intelligence, 7 (2013), pp. 1–41
- [12] M. DORIGO, M. BIRATTARI AND M. BRAMBILLA, *Swarm robotics*, Scholarpedia, 9 (2014), pp. 1463
- [13] S. KONUR, C. DIXON AND M. FISHER, *Analysing robot swarm behaviour via probabilistic model checking*, Robotics and Autonomous Systems, 60 (2012), pp. 199–213

- [14] A. SAXENA, C. SATSANGI AND A. SAXENA, *Collective collaboration for optimal path formation and goal hunting through swarm robot*, 5th International Conference on Confluence The Next Generation Information Technology Summit (2014), pp. 309–312
- [15] D. H. KIM, *Self-organization for multi-agent groups*, International Journal of Control Automation and Systems, 2 (2004), pp. 333–342
- [16] S. NOUYAN, R. GROSS, M. BONANI, F. MONDADA AND M. DORIGO, *Teamwork in self-organized robot colonies*, IEEE Transactions on Evolutionary Computation, 13 (2009), pp. 695–711.
- [17] M. NTIKA, P. KEFALAS AND I. STAMATOPOULOU, *Formal modelling and simulation of a multi-agent nano-robotic drug delivery system*, Scalable Computing: Practice and Experience, 15 (2014), pp. 217–230.
- [18] A. FT. WINFIELD, *Foraging robots*, Encyclopedia of complexity and systems science, pp. 3682–3700, 2009.
- [19] K. E. HOLEKAMP, J. E. SMITH, C. C. STRELIOFF, R. C. VAN HORN AND H. E. WATTS, *Society, demography and genetic structure in the spotted hyena*, Molecular Ecology, 21 (2012), pp. 613–632.
- [20] P. E. STANDER AND S. D. ALBON, *Hunting success of lions in a semi-arid environment*, Symposia of the Zoological Society of London, 1993, pp. 127–143.
- [21] A. ARAB, A. M. COSTA-LEONARDO AND OTHERS, *Dynamics of foraging and recruitment behavior in the Asian subterranean termite *Coptotermes gestroi* (Rhinotermitidae)*, Psyche: A Journal of Entomology, 2012.
- [22] T. KUYUCU, I. TANEV AND K. SHIMOHARA, *Evolutionary optimization of pheromone-based stigmergic communication*, Applications of Evolutionary Computation, 2012, pp. 63–72.
- [23] N. HOFF, R. WOOD AND R. NAGPAL, *Distributed Colony-Level Algorithm Switching for Robot Swarm Foraging*, Springer Distributed Autonomous Robotic Systems, 2013, pp. 417–430.
- [24] S. P. BEEBY, M. J. TUDOR AND NM. WHITE, *Energy harvesting vibration sources for microsystems applications*, Measurement science and technology, 17 (2006), pp. 175.
- [25] M. JB. KRIEGER AND JB. BILLETTER, *The call of duty: Self-organised task allocation in a population of up to twelve mobile robots*, Robotics and Autonomous Systems, 30 (2000), pp. 65–84.
- [26] T. H. LABELLA, M. DORIGO AND J. L. DENEUBOURG, *Division of labor in a group of robots inspired by ants' foraging behavior*, ACM Transactions on Autonomous and Adaptive Systems (TAAS), 1 (2006), pp. 4–25.
- [27] W. LIU, A. FT. WINFIELD, J. SA, J. CHEN AND L. DOU, *Towards energy optimization: Emergent task allocation in a swarm of foraging robots*, Adaptive behavior, 15 (2007), pp. 289–305.
- [28] A. CAMPO AND M. DORIGO, *Efficient multi-foraging in swarm robotics*, Advances in Artificial Life, 2007, pp. 696–705
- [29] J. H. LEE, C. W. AHN AND J. AN, *A honey bee swarm-inspired cooperation algorithm for foraging swarm robots: An empirical analysis*, IEEE/ASME International Conference on Advanced Intelligent Mechatronics (AIM), 2013, pp. 489–493
- [30] A. COUTURE-BEILAND R. T. VAUGHAN, *Adaptive mobile charging stations for multi-robot systems*, IEEE/RSJ International Conference on Intelligent Robots and Systems (IROS), 2009, pp. 1363–1368
- [31] S. KERNBACH AND O. KERNBACH, *Collective energy homeostasis in a large-scale microrobotic swarm*, Robotics and Autonomous Systems, 59 (2011), pp. 1090–1101
- [32] A. F. WINFIELD, S. KERNBACH AND T. SCHMICKL, *Collective foraging: cleaning, energy harvesting and trophallaxis*, Handbook of Collective Robotics: Fundamentals and Challenges, Pan Stanford Publishing, Singapore, 2011, pp. 257–300
- [33] O. SIMONIN, F. CHARPILLET AND E. THIERRY, *Revisiting wavefront construction with collective agents: an approach to foraging*, Swarm Intelligence, (2014), pp. 113–138.
- [34] O. ZEDADRA, N. JOUANDEAU, H. SERIDI AND G. FORTINO, *A Distributed Foraging Algorithm Based on Artificial Potential Field*, Proceedings of the 12th IEEE International Symposium on Programming and Systems (ISPS), 2015, pp. 1–6.
- [35] R. A. BROOKS, *A robust layered control system for a mobile robot*, Journal of Robotics and Automation, 2 (1986), pp. 14–23.
- [36] J. BARRAQUAND, B. LANGLOIS AND J. -C. LATOMBE, *Numerical potential field techniques for robot path planning*, IEEE Transactions on Systems, Man and Cybernetics, 22 (1992), pp. 224–241.
- [37] T. BALCH, *Grid-based navigation for mobile robots*, The Robotics Practitioner, 2 (1996), pp. 6–11.
- [38] Y. P. YEAN AND RM. K. CHETTY, *An efficient grid based navigation of wheeled mobile robots based on visual perception*, Trends in Intelligent Robotics, Automation, and Manufacturing, 2012, pp. 128–135.
- [39] B. LAU, C. SPRUNK AND W. BURGARD, *Efficient grid-based spatial representations for robot navigation in dynamic environments*, Robotics and Autonomous Systems, 61 (2013), pp. 1116–1130.
- [40] U. WILENSKY, NetLogo. <http://ccl.northwestern.edu/netlogo/>, Center for Connected Learning and Computer-Based Modeling, Northwestern University, Evanston, IL, 1999.

*Edited by:* Dana Petcu

*Received:* August 27, 2015

*Accepted:* October 4, 2015





## ON PROCESSING EXTREME DATA <sup>1</sup>

DANA PETCU, GABRIEL IUHASZ, DANIEL POP<sup>2</sup>, DOMENICO TALIA<sup>3</sup>, JESUS CARRETERO<sup>4</sup>, RADU PRODAN, THOMAS FAHRINGER, IVAN GRASSO<sup>5</sup>, RAMÓN DOALLO, MARÍA J. MARTÍN, BASILIO B. FRAGUELA<sup>6</sup>, ROMAN TROBEC, MATJAŽ DEPOLLI<sup>7</sup>, FRANCISCO ALMEIDA RODRIGUEZ, FRANCISCO DE SANDE<sup>8</sup>, GEORGES DA COSTA, JEAN-MARC PIERSON<sup>9</sup>, STERGIOS ANASTASIADIS, ARISTIDES BARTZOKAS, CHRISTOS LOLIS<sup>10</sup>, PEDRO GONÇALVES, FABRICE BRITO<sup>11</sup> AND NICK BROWN<sup>12</sup>

**Abstract.** Extreme Data is an incarnation of Big Data concept distinguished by the massive amounts of data that must be queried, communicated and analyzed in near real-time by using a very large number of memory or storage elements and exascale computing systems. Immediate examples are the scientific data produced at a rate of hundreds of gigabits-per-second that must be stored, filtered and analyzed, the millions of images per day that must be analyzed in parallel, the one billion of social data posts queried in real-time on an in-memory components database. Traditional disks or commercial storage nowadays cannot handle the extreme scale of such application data.

Following the need of improvement of current concepts and technologies, we focus in this paper on the needs of data intensive applications running on systems composed of up to millions of computing elements (exascale systems). We propose in this paper a methodology to advance the state-of-the-art. The starting point is the definition of new programming paradigms, APIs, runtime tools and methodologies for expressing data-intensive tasks on exascale systems. This will pave the way for the exploitation of massive parallelism over a simplified model of the system architecture, thus promoting high performance and efficiency, offering powerful operations and mechanisms for processing extreme data sources at high speed and/or real time.

**Key words:** Extreme Data, HPC, Exascale Systems, Extreme Computing, Parallel Programming Models, Scalable Data Analysis

**AMS subject classifications.** 65Y05, 68W10

**1. Introduction.** Inheriting the characteristics of Big Data, Extreme Data has at least three main dimensions, Volume, Variety and Velocity. However, the Extreme attribute is associated with a virulence of the Vs and their strong inter-relationship. The Volume dimension is well explained by the Big Data concept describing the data size or weight. However, in the context of scientific computing, the extreme data processing has a high degree of complexity due to the tighter interactions among different parts of the dataset during processing. As a result, the volume that can be processed is currently limited and existing abstractions such as the MapReduce model applicable to Big Data are insufficient. New programming paradigms are needed to be specially tailored to increase the volume of the scientific data processed by HPC systems.

The processing is complicated by data Variety: e.g. the simple requirement of adding and processing data from various streaming sources is not yet supported by the current HPC tools in the context of new types appearing every day. Furthermore, the challenge is not only storing the data, but also getting data in and out of store from the data centers and offering support for reproducibility and data provenance assurance.

The Velocity express how rapidly one can move data from a data volume to a user. Extreme velocity is crucial for real-time advanced data visualization and analytics (embedded analytics into the databases is the only current solution).

---

<sup>1</sup>This work is partially supported by EU under the COST Program Action IC1305: Network for Sustainable Ultrascale Computing (NESUS).

<sup>2</sup>West University of Timișoara, Romania

<sup>3</sup>University of Calabria, Italy

<sup>4</sup>University Carlos III of Madrid, Spain

<sup>5</sup>University of Innsbruck, Austria

<sup>6</sup>University of Coruña, Spain

<sup>7</sup>Jozef Stefan Institute, Slovenia

<sup>8</sup>University of La Laguna, Spain

<sup>9</sup>IRIT, University of Toulouse, France

<sup>10</sup>University of Ioannina, Greece

<sup>11</sup>Terradue, Italy

<sup>12</sup>EPCC, University of Edinburgh, Scotland, UK

In addition to the above three dimensions inherited from Big Data, we consider relevant for extreme data a fourth dimension, Value. The Value can be obtained by analyzing datasets and so extracting knowledge from them. Part of the research work is dedicated to the design and development of methods and tools for programming extreme data mining applications and extracting value from extreme data. The Value is mentioned also as a fourth dimension in High Performance Data Analysis (HPDA, [18]) concept. HPDA needs HPC resources and smart algorithms to offer solutions in near-real time, implies search and pattern discovery, simulation and analytics, and deals with regular and irregular data patterns, as well as partitionable and non-partitionable problems.

In this paper we propose a roadmap to developing new programming models for extreme data applications and ensure their take-up. More precisely, in order to offer support to the extreme data processing through HPC, we propose to change the current programming paradigms by following a data-driven model (to increase the Volume), the heterogeneous data access mechanisms (to increase the Variety), and the methods for data analytics/mining (to increase the Value). The scale of the changes on the three dimensions (Volume, Value, Variety) should be finally estimated through the redesign and reimplementation of existing scientific applications, dealing with large volumes of data. We are not discussing in this paper how the velocity can be increased, as being currently subject of co-design techniques.

The proposed roadmap is aligned with the challenges identified by PRACE [75], HiPEAC [39], PlanetHPC [74] and ETP4HPC [28]. As underlined by the PRACE report "The Scientific Case for High-performance Computing in Europe 2012–2020", handling large data volumes generated by research is both a major challenge and opportunity for future HPC systems, and integrated environments for compute and data are expected to emerge. Another identified challenge is the end-to-end management of, and fast access to, large and diverse data sets through the infrastructure hierarchy; most application areas foresee the need to run several long-time jobs at sustained high performance to generate core datasets and many shorter-time jobs at lower performance for pre- and post-processing. The HiPEAC initiative recommends to address the issues of efficiency (maximizing power efficiency and performance through heterogeneous computer system design and catering for data locality), dependability and applications (bridging the gap between the growth of data and processing power; safety, predictability and ubiquitous availability of systems). The main technological challenges identified by PlanetHPC are data locality (i.e., the proximity of data to the processing location), new programming models and tools (for massively parallel and heterogeneous systems), technologies supporting new and emerging applications that require robust HPC with real-time capability, data-intensive HPC and low-energy computing from both an architectural and application perspective. ETP4HPC SRA (Strategic Research Agenda) underlines that important trends or needs are efficient communication and data movements at all levels and on different flavors and levels of architectures.

The Japanese JST-CREST on-going programme Extreme Big Data (EBD) aims to achieve the convergence of Supercomputing and Big Data [63]. EBD is now focusing on the hierarchical use of new generation non-volatile memories and processor-in-memory technologies, hierarchical management of memory objects and their high resiliency, and resource management to accommodate complex workflows being able to minimize data movement. EBD advocates the need for a convergent SW/HW architecture and their software stack will be implemented in the next generation of Japanese supercomputers (including also new strategies for scaling on the Velocity dimension using new interconnection network topologies). The co-design EBD applications include climate simulation with real-time data assimilation to predict extreme weather phenomena.

In this paper we advocate for an extended level of support for the development, deployment and execution of extreme data application using the current HPC facilities, while we do not exclude the fact that co-design techniques can follow the proposed approach. The four pillars of the proposed roadmap are the following:

1. Design and develop new HPC programming and energy models for extreme data applications. Designing and developing programming paradigms and mechanisms is needed to better support the implementation of scalable algorithms and applications on exascale computing systems. Models for energy consumption estimation are needed at an application level, as well as efficient runtime mechanisms for supporting the workload executions expected to scale on very large computing systems, including support to cope with the dynamic variability in the required or available resources.
2. Build new tools for monitoring and data-analysis for extreme data applications. Designing and de-

veloping scalable monitoring and data analysis tools should include low-level instrumentation, data collection, mining and data-centric online performance analysis with the ability to perform at the exascale level. Beyond the use of performance metrics, the efficiency needs to be targeted through advanced modelling and correlation heuristics aiming to understand their inter-relationships, essential for online optimisation and tuning.

3. Adapt the data management and storage techniques to the extreme scale. Providing high-performance and reliable support for I/O, storage and data-throughput, as well as resilience capabilities are needed. The strategies to enhance an application's data locality need to be coupled with dynamic I/O configurations by restructuring the I/O stack functionalities, and by providing predictive and adaptive data allocation strategies. The resilience problem in the I/O stack needs to be treated by sharing cross-cutting issues and highly scalable and energy-efficient cross-layer checkpointing strategies, using the I/O hierarchy and memory storage greedily. Object-based file systems and scalable data stores need to be promoted for efficient and durable storage structures for exascale applications.
4. Validate the concepts and tools usefulness through extreme data applications. Two main directions are considered in this paper: environmental science (particularly Earth observation, weather forecasting and urban computing fields) and dynamic systems simulations.

Section 2 discusses how the state of the art in processing large datasets should be advanced in order to reach the exascale dimension. Section 3 introduces an approach to the proposed advances. We draw the conclusions in the closing section.

**2. Advancing the state of the art.** We follow in this section the topics related to exascale systems from the ETP4HPC Strategic Research Agenda [28], selecting those connected to the extreme data processing field:

1. Programming Environments: Non-conventional parallel programming; APIs for auto-tuning performance or energy; Inspection of data locality at Exascale level; New metrics, analysis techniques and models;
2. System Software and Management: On-the-fly data analysis, data mining; Fault-tolerant MPI and checkpointing;
3. Balancing Compute Subsystem, I/O and storage performance: Hardware resilient Exascale storage demo; Big Data + HPC integrated software stack;
4. Big Data and HPC Usage Models: Problem-solving environments for large data.

More precisely, in this section we try to identify the limitations of the current approaches for data processing using HPC in the conditions of Extreme Data, as well as potential paths to overpass these limitations.

### 2.1. Advancing the Programming Environments.

**2.1.1. Non-conventional parallel programming.** A parallel programming model provides a set of abstractions that simplifies and structures the way a programmer thinks about and expresses a parallel algorithm. High-level programming models help programmers access and use resources abstracted from physical entities (cores or memory). This is done to facilitate programming and to improve the software portability and to increase the productivity. The use of high-level programming abstractions also helps by using a reduced set of programming patterns that limits errors, reduces programming time and facilitates resource exploitation.

Programming paradigms traditionally used in parallel and distributed systems, like MPI, Map-Reduce, OpenMP, and OpenCL are not sufficient for developing codes designed to run on systems composed of a massive amount of processing nodes. To reach exascale requires the definition of new programming paradigms combining abstraction with scalability and performance. Hybrid approaches (shared/distributed memory) and subsets of communication mechanisms based on locality and grouping are currently investigated. The approaches proposed until now are based on the adaptation of traditional parallel programming languages and hybrid solutions. This incremental approach is too conservative, often resulting in very complicated code with the risk of limiting the scalability of programs on millions of cores.

Approaches based on a partitioned global address space (PGAS) memory model appear to be more suited in meeting the exascale challenge. Today, they are investigated as a potential solution that may limit the cost of shared memory access, however load balancing is still an open question. Many current parallel programming solutions contain an implicit trade-off between simplicity and performance; those which abstract the programmer

from the lower level parallel details often sacrifice performance and scalability in the name of simplicity, and vice versa. Many current implementations of the PGAS model are no exception to this and unfortunately, limited progress has been done in last few years toward the implementation of simple models that can be used to program at any scale and performance. The need for scalable programming models continues and the emergence of new hardware architectures makes this need more urgent.

MPI offers low programmability due to the fragmented view of data it offers. This resulted in the proposal of the PGAS model, whose current implementations (e.g. UPC [95], CAF [73], Global Arrays [71]) inherit the SPMD model due to their multi-threaded view and they have no support for hierarchical decomposition, which is key for exascale computing. Additionally, these tools only focus on communication, leaving to the user all the issues related to the management of large volumes of data that appear in exascale problems.

Novel, complex abstract structures are needed for extreme data application support. The MapReduce model is often oversold; although frequently used on clusters and Cloud-based applications, additional research is needed to develop scalable higher-level models and tools. Defining new programming paradigms and APIs to represent data-intensive tasks on exascale systems will allow the exploitation of massive parallelism in a way that provides an abstraction of the system architecture, promotes the high performance and efficiency, and offers powerful operations and mechanisms for processing extreme data in reduced and/or real time. Such strategy can open the way to implement many data-intensive applications in several application domains both in science and business.

Heterogeneity is crucial to achieve exascale computing and it is in fact being increasingly adopted in high-performance petascale systems, as the first entries of the TOP500 show. For instance, the June 2014 list includes 62 systems with accelerators, a 17% raise comparing to 53 in the previous list. These platforms require the cooperation of thousands of nodes, with MPI being the state-of-the-art, sometimes complemented by other tools such as OpenMP for intra-node communication, completed by a variety of APIs for managing the accelerators, OpenCL being the most portable solution.

There are previous attempts for novel data processing languages such as DISPEL [20], which is an imperative workflow-based scripting language aimed at supporting analysis of streamed data. The programmer describes workflows for data intensive applications, a workflow being a knowledge discovery activity, where data is streamed through and transformed into higher level knowledge. Apart from requiring the data scientist to learn a variety of new concepts, this language is heavily integrated with the ADMIRE platform and requires the features and workflow provided by the platform. The use of DISPEL is supported in the seismology e-science data analysis environment of the VERCE [96] project. DISPEL was ported from the ADMIRE platform to Python and `dispel4py` [21] was created, which shares the same concepts as DISPEL but it is integrated with a platform familiar to seismologists. This approach of building abstractions on top of an already familiar programming language has many advantages, such as an easy integration with existing tools, or a wider acceptance by community. The R [78] language is designed for statistical computing and graphics, one of its strengths being the integrated support for data manipulation and calculation; for instance, effective data storage and calculations on matrices. As a functional language, R might require, to some extent, the data community to learn new concepts, which may impact its acceptability. The SPRINT [85] project has developed an easy to use parallel version of R, aimed at the bioinformatics community. This technology allows the addition of parallel functions, without requiring in depth parallel programming knowledge. SPRINT has been very successful in this domain, but it is not designed for exascale and, although it works well on a thousand of cores, it is not designed to scale up to hundreds of thousands or millions of cores.

We argue that libraries are needed to support abstract data types (ADTs) that represent global explicitly-distributed objects in a widely spread object-oriented language (the main focus can be on arrays because of their ubiquitousness). Since objects contain both data and the key semantics of their management, the methods of ADT can provide users with optimized implementation of common operations and underlying support for requirements for exascale applications. The ADT methods can provide data-parallel semantics, and can encapsulate abstractions that allow for hierarchical decomposition of the data and the representation of irregular problems and operations. The meta-information within ADTs, together with the high-level semantics of its operation, can allow one to optimize its operation in exascale environments while strongly reducing the code complexity. Finally, the usage of a widely-adopted language can favor code reuse and the gradual migration



of legacy code to exascale systems on top of these ADTs.

The availability of many accelerators (GPUs, Phi, FPGAs etc.) with different APIs to manage them and no clear winner at this point leads to possibility of many more appearing in the future. The usage of OpenCL in exascale applications, which is the only portable approach that avoids lock-ins and code rewrites, seems to be a promising choice. Unfortunately, the OpenCL API is too low level [72], resulting in code verbosity and low productivity of programmers, who need to manually perform buffer allocations, data transfers, synchronizations etc. High level annotations [81, 2] or embedded languages [97] built on top of OpenCL that automate these tasks and hide their complexity are a better approach. Several authors have considered the programmability of accelerators on top of OpenCL across a cluster [7, 35]; however, existing solutions only abstract away some complexities of OpenCL but still expose other low-level details or restrict the non-accelerator part of an application to a single node.

In order to exploit all the available hardware in exascale systems, we need to extend and evolve the high-level programming of accelerators (e.g., [81, 97, 2]) into high-productivity seamless approaches, for instance, through the natural integration with the ADT previously described.

**2.1.2. APIs for auto-tuning performance or energy.** At the moment, most monitoring tools of HPC systems directly measure only metrics of performance. Classical monitoring tools, such as Ganglia or Nagios, track the processor and memory load, the network bandwidth and the communication pattern. But this approach can only improve one key metric, the raw performance. In a more realistic world, multiple conflicting objectives need to be achieved. Indeed, in some cases the improvement of performance or energy consumption is a difficult choice because the optimization of the one may have a negative impact on the other. In order to reach an efficient state, any runtime for optimizing energy and performance requires in-depth information about the system state along with the ability to predict the impact of possible choices. Several tools already exist [19, 9] to evaluate the power consumption of servers or applications without specialized hardware, only using information of resource consumption at the system level. However, the current solutions either are imprecise or consume resources intensively. In an HPC environment, we need to optimize both the performance and energy through the improvement of current approaches. One way is to design and implement adaptive prediction tools. Indeed, a decision system for auto-tuning the performance and energy needs to predict the impact of its decision in order to provide efficiency. At the moment, most models [62] are only considering instantaneous power consumption, while not trying to predict its evolution.

**2.1.3. Inspection of data locality at Exascale level.** Data locality is a major concern for I/O in current Petaflop machines. Nowadays, data locality is managed independently at various levels such as the application, middleware, or file system. At the lowest level of the I/O stack, parallel file systems such as GPFS [42], Orange/PVFS [77] or Lustre [60] manage block-based or object-based storage through parallel servers running on storage nodes. These parallel file systems strive to comply with the POSIX requirements. However, one main critique for POSIX is that it does not expose data locality, even though researchers agree that locality-awareness is a key factor for building exascale systems [79].

Other scalable file systems such as GFS [34] have dropped the POSIX interface and been co-designed with processing frameworks such as MapReduce [22]. Although these frameworks simplify programming for a class of embarrassingly parallel data-intensive computations based on best-effort strategies to co-locate computation and data, they are not generic enough to efficiently address the needs of scientific applications and have not been widely adopted on the High End Computing (HEC) infrastructure. The main take-outs from their experience are co-design and locality-aware computing [24].

The most widely used middleware in HEC systems is the MPI-IO [68]. The standard MPI-IO data operations are not locality-aware. Additionally, there are no mechanisms allowing data accesses to take advantage of data layout in the file system (e.g. I/O caching, data distribution over servers, block alignment). Some applications are using high-level I/O libraries, such as HDF5 [37] and ParallelNetCDF [55] that map application data models to storage data models through MPI-IO. However, these libraries often require experience to achieve reasonable performance and scalability.

**2.1.4. New metrics, analysis techniques and models.** Over the last years, a large number of performance measurement and analysis tools (like the ones described in [82, 67, 65]) have been created for the new

heterogeneous, many-core, parallel computing architectures and systems. These tools support low-level instrumentation, performance measurement and analysis; they are based on hardware counters, time measurements, call graphs, and tools for tracing the operating system or measuring the performance of specific programming models; and they cover, for instance, multi-threaded, OpenMP, and MPI programs. A major drawback of these tools is that they operate at the process or thread level which will clearly do not scale to the exascale level.

In order to avoid such major bottlenecks in exascale systems, we argue that a new tool design is needed shifting the focus from single thread and regions to the distribution and layout of data.

The first issue is whether performance analysis should be done in an online or offline manner. The online approach implies that the application is still executing while performance data is processed to support the on-the-fly optimization of an application for given objectives. This is usually considered more difficult in comparison to offline analysis, since the analysis consumes resources in parallel to the investigated application (possibly causing perturbation). A further difficulty is the processing of data streams rather than full data sets, i.e. the analysis must work on a subset with missing —potentially important— information that might appear later. Offline analysis on the other hand does not cause any performance perturbation for the application and has the entire data set available. However, it usually requires more storage space and inherently lacks support for on-the-fly optimizations. Existing tools mostly focus on offline analysis, while online analysis is only addressed in isolated efforts [67].

An important issue involved in performance analysis at the exascale level is the reduction of the amount of data involved. Ideally, we should minimize the required storage space —and the amount of input data for analysis— at maximum retained information. There are several methods and techniques that try to balance this trade-off such as clustering of data [32, 57] or pattern extraction [31]. Thus, they reduce the amount of performance data but provide a higher level of information in comparison to other techniques of performance instrumentation and measurement, such as sampling or profiling, that only give summary information. Nevertheless, few tools employ such techniques by default and, despite their applicability, they have never been used for online performance analysis.

The lossless compression methods that are widely available may have unsuitable compression ratio or excessive overhead, and do not affect the amount of data that needs to be analyzed. In addition, some tools like TAU [82] or Paradyn [67] support self-limitation of instrumentation perturbation, e.g., by estimating the overhead caused by instrumentation function calls and stopping instrumentation if that overhead reaches a certain threshold. By decreasing the instrumentation and analysis overhead, this also increases the scalability of the tools. Although this approach is successful in reducing the amount of produced performance data, it also limits its usefulness because there might be program phases that are not represented by any performance data. Once the data is analyzed, the issue of sophisticated visualization remains. In particular, subgraph folding [80] addresses the visualization of large-scale data by merging multiple subgraphs of similar information into a single, composite subgraph.

Measurement and analysis tools for non-functional parameters (NFPs, including execution time, memory usage and energy consumption) should be analyzed. Holistic views of NFPs (including a novel data-centric view to replace the traditional region-centric ones) characterizing applications, components, runtime system and computing system behaviour are needed. The tools need to correlate NFPs across these views. Measurement techniques need to ensure correct and accurate mappings of NFPs from the computing system level to the application level. In particular, measurement techniques should be selectively used for different parts of applications and computing systems to control the measurement overhead and accuracy.

In order to support dynamic performance optimization at exascale, scalable measurement and analysis techniques should target the on-the-fly classification and frequent pattern algorithms, NFP estimation techniques, and comprehensive analysis patterns for detecting and understanding performance problems. Tools that enable domain experts to control the granularity and accuracy of performance analysis are needed.

There are also approaches that compute the Pareto frontier to represent the correlation between different conflicting objectives. Examples targeting two objectives refer to time and operational cost [104] or to execution time and energy consumption [76] but without considering costs and utilisation. For instance, [12] employs the hyper-volume metric for pruning the trade-off solutions generated in each step, at cost that is exponential with the number of objectives. On the other hand, genetic algorithms can provide better solutions [100, 89]; however,

it is well-known that their performance unacceptably degrades beyond three objectives [51]. Few approaches target three objectives, like the ones from [49, 83]. All of them are nature-inspired algorithms that require a long time for convergence to high-quality solutions. All these approaches do not target data-intensive applications and do not apply energy modelling and prediction techniques.

Another important aspect to be considered is the use of GPGPU (CUDA, OpenCL) for many multi-objective optimization problems. GPGPUs are attractive for their processing power and cost effectiveness [64]. Their main drawback is that not all methods are suitable for this type of architecture and most algorithms need to be redesigned and reimplemented. Different optimization techniques have been implemented for a variety of problem types [58, 59] and also for real world applications with stringent time and computational constraints [93]. The advantages and disadvantages of this approach need to be analyzed, when applied to exascale problems and data.

## 2.2. Advancing the System Software and Management.

**2.2.1. On-the-fly data analysis and data mining.** Data analysis tasks usually involve a large amount of variables that are recorded or sampled. The problems caused by anomalous values in exascale data can be disastrous from a data-analytic point of view. In order to obtain a coherent analysis, the detection of outlying observations is paramount. Outliers can in some instances carry important information (e.g. a century flooding event with occurring probability of 1%). However outliers depend heavily on the nature of the data and the expected outcome of the analysis. These outliers are candidates for potentially aberrant data that ultimately can lead to poor sample-based performance or model degradation/misspecification. Outliers detection should happen before modeling and data analysis. However, not only pre-processing (in particular outliers detection) but also stream data analysis encounters difficulties in on-line extraction of models from data streams.

There are several types of anomaly detection mechanisms. Classification techniques require labeled data (distance-based kNN). These types of methods make the assumption that 'normal' data occurs in dense neighborhoods while anomalies happen far from these. There are of course other methods which can be of some value, such as artificial neural networks [87, 69], SVM [103], Bayesian Networks [45] or Decision Trees [53]. In the case of unsupervised learning methods, outliers are considered part of no cluster, while normal instances of data are part of a cluster. Clustering methods include DBSCAN [17], SNN [3], k-Means, SOM, HMM, WaveCluster, FindOUT or FSM [88]. Anomaly detection can be used to in filtering significant features out from data sets. These features can represent a wide variety of events ranging from unwanted behavior to identifying new data. Thus, it can be used to process data as well as the behavior of complex systems.

The ADMIRE [4] platform is a software stack that implements an architecture where a wide range of data analytics tools are connected together through specific interaction points known as gateways. Although this approach has delivered some success, three years after project completion it has not gained significant traction in the wider area of data analysis. One of the reasons might be the fact that ADMIRE uses technologies such as REST and WSDL. This makes the architecture seem more suited towards cloud/cluster analytics, rather than HPC data analytics at exascale. Weka [99] is a collection of machine learning algorithms for data mining tasks. There are a variety of tools such as data pre-processing, classification and visualization which can be used directly or called from Java code. The fact that this is a Java library limits the suitability to HPC. Moreover, we must mention that distributed versions of the Weka framework have been developed (e.g., Weka4WS [94]), but they are suitable for small/medium size Grids or Cloud platforms, not for extreme computing systems where a massive degree of parallelism must be exploited.

Multivariate exascale data poses a significant problem for data mining and visualization methodologies. This type of data requires many degrees of freedom which can lead to poor data comprehension, and visualization amplifies this problem [26]. The ability to generate data will by far outweigh the ability to store this data. Also, the movement of the data in large quantities through the memory hierarchy to more permanent storage is extremely costly in terms of power [26]. The development of on-the-fly analysis methodologies can provide important advantages, such as data comprehension and improved prediction/classification performance.

Dimensionality reduction and feature selection can happen as early as possible in the data processing workflow. Identifying the most important features in a particular data set can help prevent potentially large execution times of data mining algorithms as well as costly data storage and transfer operations [15]. Dimensionality reduction methodologies that are good candidates for further investigations and potentially further

improvements are Principal Component Analysis [5, 103], Wrapper Methods [90, 40, 47] and others [101, 43, 102]. The idiosyncrasies of each method have to be taken into consideration in order to effectively work on exascale systems.

**2.2.2. Fault-tolerant MPI and checkpointing.** Pure hardware solutions are not enough to deal with the number of failures of large systems. For this reason, hardware failures must be tolerated by the applications to ensure that not all computation done is lost on machine failures. Checkpointing and rollback recovery is one of the most popular techniques to provide fault tolerance support to MPI parallel applications. It periodically saves the computation state to stable storage, so that the application execution can be resumed by restoring such state.

In case of failure, most of the current checkpointing and rollback solutions restart all the processes from their last checkpoint. However, a complete restart is unnecessary, since most of the nodes will still be alive. Moreover, it has important drawbacks. Firstly, full restart implies a job re-queuing, with the consequent loss of time. Secondly, the assigned set of execution nodes is generally different from the original one. As a result, checkpoint data must be moved across the interconnection network in order to restart the computation. This usually causes significant network contention and therefore high overheads. All these limitations should be overcome through the support for malleable jobs, that is, parallel programs that are able to modify the number of required processors at run-time. This feature allows the automatic adaptation of the parallel execution to the available resources, coping with hardware errors and avoiding the restart of the whole application.

The literature includes several proposals for transforming MPI applications into malleable jobs. However, most of them are very restrictive with respect to the kind of supported applications. Indeed, only iterative or master-slave applications are considered (e.g., [61, 86, 14]), because in these cases the modification of the number of processes is much easier than in a general application. Furthermore, in these approaches reconfiguration can only take place in very specific points within the applications. Thus, new solutions are needed to implement MPI malleable applications in a general and scalable way.

Malleability not only offers advantages from the fault-tolerance point of view [33]. It also provides a higher productivity and a better response time [11, 41]. These characteristics allow to improve the usage of resources, which will have a direct effect on the energy consumption of application execution, resulting in both cost savings and a greener computing.

### 2.3. Advancing the Balance of Compute, I/O and Storage Performance.

**2.3.1. Hardware resilient Exascale storage demo.** Traditionally I/O is an activity that is performed before or after the main simulation, analysis computation, or periodically for activities such as checkpointing. Instead, the I/O should be regarded as an integral activity which must be optimized while architecting the underlying software [25]. As HPC systems are becoming larger, the overall system resilience decreases. The resilience of an application in an exascale system depends significantly on the I/O system because saving the state of the application through checkpoint/restart remains an essential component of the global system resilience [23]. The overhead for performing checkpoints and the consumed energy can both be optimized by leveraging new non-volatile memory [29].

We believe that new memory and storage hierarchies can drastically impact performance and resilience. Therefore, we consider worth investigating the integration of non-volatile memory within nodes, interconnects and networks or within I/O storage nodes. Seamless data migration between the multiple tiers of memory and storage is key to achieving the exascale. New technologies, such as flash memory (SSD), phase-change RAM and accelerators, will provide new opportunities to achieve both the above properties (stable local storage, faster checkpointing, faster checkpoint compression etc).

The traditional homogeneous I/O interfaces do not explicitly consider the type of an I/O operation. However, a checkpointing I/O activity is different from an I/O activity. Therefore, we need purpose-driven I/O software layers and cross-layer data management that is specialized for resilience [44], such as checkpointing in memory, hierarchical checkpointing, and checkpointing that leverages the data layout. To achieve resilience and integrity, objects should be replicated in physically separate zones [6]. An example in this direction is VIDAS, an object-based virtualized data sharing for High Performance Storage I/O [56]. Using fast memory (RAM, NVRAM, SSD, etc.) at intermediate storage levels in the hierarchy is becoming more and more popular. Thus,

some cached parallel file systems are now available as powerful I/O tools such as memcachedFS and Panache [27]. Nonetheless, resilience requires a system-wide approach. A cross-layer mechanism with clear failure semantics can support the design of resilient techniques and optimizations at different stack layers. However, it is also important to provide isolation between global/local storage, so that there can be a timely notification and avoidance of failures to ensure data integrity.

**2.3.2. Big Data + HPC integrated SW stack.** A recent study characterized the storage I/O of computational scientific applications handling large amounts of data, including jobs in Earth science, nuclear physics, energy, and climate [13]. It has been found that the majority of applications prefer to use POSIX interfaces rather than the MPI-IO interface or high-level libraries. Additionally, processes accessed either unique files, shared files, partially shared files or zero files. A surprising amount of data is stored on small files in the range 64KiB-128KiB, and 86% of the files have size below 1MiB. The read and write size was 100KiB to 1MiB across most jobs, although two specific jobs biased the most popular write size between 100B and 1KiB. Checkpointing is recognized as the primary storage driver. Current requirements are specifying that a checkpoint of up to 64PB should complete in 300s.

Another recent study introduced methods to automatically identify I/O patterns at the block level and utilized them to manage the metadata indexing and support data prefetching in physics and geoscience applications [38]. Statistical analysis of NetCDF scientific datasets was successfully explored over the Hadoop platform developed for big data applications [10]. Another study identified several common characteristics between the PVFS distributed file-system used in high-performance computing, and HDFS used in big data analytics [91]. Quality of service in shared storage servers has been previously investigated in the context of transactional and analytical workloads. Promising techniques include automated configuration of prefetch and writeback I/O size along with quanta-based device scheduling [98]. The latest approaches proactively manage quality objectives across multiple resources (e.g., network and storage) but are far from handling exascale data in the complex scientific processing [106].

Based on prior research, we recognize the challenge of managing exascale data in scientific applications and their peculiarities with respect to big data processing for analytical purposes. However, the characterization of I/O requirements of an application can include system services such as monitoring. One way to address current bottlenecks emerging from the handling of numerous files or small I/O requests is through support for storage and network I/O aggregation at the client side. Quality of service in exascale I/O performance is important in this context. The guaranteed performance obtained from shared storage servers can be improved through the exploitation of caching at the client side and efficient storage management at the server. The durability restrictions can be overcome with persistent caching over high-performance storage devices. The main advancement from existing methods can be the native incorporation of the proposed improvements within the distributed filesystem or datastore rather than adding the aggregation support in middleware layers between the client and the storage backend.

**2.4. Advancing the Big Data and HPC Usage Models: Problem-solving environments for large data.** While there is much debate about the programming models used to program exascale computing systems, the main requirements of the applications targeting this extreme scale are clear: a very large number of threads, limited communication (in space and time) and synchronization, tolerance for execution time variance, scalable data access and low energy consumption [36]. New applications must be written to satisfy these requirements. Scaling up applications to exascale will require programming efforts even if new programming models prove to be adequate for instance handling limited data exchange asynchronously will require new algorithms. Therefore, programmer productivity also matters. Writing efficient programs for a large scale computing platform is a difficult engineering endeavor that requires a lot of knowledge and experience also because complex engineering tasks are not easy to automate [84]. High-level and efficient programming environments will help in achieving this objective.

Exascale-ready problem-solving environments (PSE) should consider computing, data flows, and energy efficiency when determining how to execute pipelined tasks; for exascale computing, measuring and acting upon the computing performance alone is insufficient [30]. Since the constituents of PSE can act as data producers or data consumers, the optimization of data-flow between them is a task that should be handled by the PSE.

For example, global monitoring from space requires new platforms that will ensure the correct exploitation

of data. This unprecedented large volume of data brings new constraints in terms of discovery, access, exploitation, and visualization. How these new volumes of Earth Observation data are integrated in data-intensive applications frameworks define the next generation of Earth Science services. Likewise, even if user and application communities share the original data, we will observe an even more diversification and specialization with new requirements, methods and protocols giving origin to innovative services.

**2.5. Overview of the limitations and the paths to overcome them.** Table 2.1 summarises the discussions from the previous subsections. They list the main limitations on large data processing and report on possible solution paths.

**3. Proposed approach and methodology.** In this section we follow the paths proposed in the previous section to overcome the current limitations in extreme data processing by proposing concrete actions.

**3.1. Design and develop new HPC programming and energy models for extreme data applications.** Exascale computing faces many challenges as parallel codes will need to control millions of threads running on many cores. Such programs will need to avoid synchronization, use less communication and memory, failures could be more frequent, and power management is needed. Whilst these considerations are critically important to the scalability of future codes, the programmers themselves typically want to concentrate on their own application and not have to deal with these lower level, tricky, details. Today no available programming models and languages provide solutions to these issues. Therefore, new programming models are required to handle these challenges.

**3.1.1. Programming paradigms and models.** High-level programming can help application developers to access and use resources without the need to manage low-level architectural entities, as a parallel programming model defines a set of programming abstractions that simplify the way by which the programmer structures and expresses his or her algorithm.

To effectively support the development of data intensive algorithms and applications on exascale systems, we consider that is urgent to design a simple but scalable programming model (e.g. a SPMD programming model) based on basic operations for data intensive/data-driven applications to deal with the use of a massive amount of processing elements and develop an API based on that model which includes operations for data access, data communication and data processing on groups of cores. The model must be able to manage a very large amount of parallelism and to implement reduced communication and synchronization.

At the extreme scale, the cost of accessing, moving, and processing data across a parallel system is enormous. This requires mechanisms, techniques and operations for efficient data access, placement and querying. In addition, scalable operations must be designed in such a way to avoid global synchronizations, centralized control and global communications. Many data scientists want to be abstracted away from these tricky, lower level, aspects of HPC until at least they have their code working and then potentially to tweak communication and distribution choices in a high level manner in order to further tune their code.

Interoperability and integration with the MapReduce model and MPI must be investigated with the main goal of achieving scalability on large-scale data processing.

**3.1.2. Productive exascale heterogeneity exploitation.** Exascale data-extreme applications require large clusters of distributed memory systems, including often heterogeneous devices of very different natures. The programming of these systems is mostly based on relatively low level standards, such as CUDA and OpenCL for the exploitation of heterogeneity, or MPI for managing communication among computing nodes, which hugely reduces the productivity of programmers.

Different data-centric abstractions can be integrated in order to provide a unified programming model and API that allows the productive programming of both heterogeneous and distributed memory systems. A software implementation can take the form of a library. Its application to reference benchmarks (like Graph500 - the data-intensive benchmark - or hpcchallenge.org) allows to gather feedback that will lead to improvements in the prototype.

In order to simplify the development of applications in heterogeneous distributed memory environments, large scale data-parallelism can be exploited on top of the abstraction of n-dimensional arrays subdivided in tiles, so that different tiles are placed on different computing nodes that process in parallel the tiles they own.

Table 2.1: Limitations on large data processing and paths to overcome them

Category	Limitations	Paths to overcome the limitations
Non-conventional parallel programming	Lack of abstract representation of data-intensive tasks; exascale computing cannot be reach without considering the heterogeneity of the systems; MPI limitations in what concern data types; PGAS do not support hierarchical decomposition; MPI and PGAS implementations focus on communications rather on management of large volumes of data.	Build abstractions on top of an already familiar programming language; new libraries to support abstract data types for explicitly distributed objects; high level annotations build on top of APIs for accelerators and evolve the low-level programming of accelerators into high productivity approaches through integration with the abstract data types.
APIs for auto-tuning performance or energy	Current monitoring tools are measuring raw performance; current tools for evaluation of power consumption use system level information, leading to an intensive consumption; instantaneous power consumption is considered.	Implement adaptive prediction tools for decision systems for auto-tuning the performance and energy.
Inspection of data locality at Exascale level	Data locality is managed independently at application, middleware and file system levels; scalable file systems are not widely adopted by HEC; MPI-IO data operations are not locality-aware.	Design high-level I/O libraries to map hierarchical data models to storage data models with scalability and performance in mind.
New metrics, analysis techniques and models	Current performance and analysis tools operate at process or thread level (not scalable); existing tools focus on offline analysis; approaches for representing correlation between conflicting optimization objectives are not targeting data-intensive applications and do not apply energy modeling or prediction techniques.	Build new tools to operate at the level of the distribution and layout of data; target the on-the-fly classification and frequent pattern algorithms, non-functional parameters estimation techniques; use of GPGPU for many multi-objective optimization problems.
On-the-fly data analysis, data mining	Current data analysis tools are designed for distributed systems and not for HPC systems; preprocessing (in particular outliers detection) and stream data analysis encounters difficulties in on-line extraction of models from data streams; multivariate exascale data have too many degrees of freedom which can lead to poor data comprehension.	Outliers detection before modeling and data analysis by using of anomaly detection mechanisms; development of on-the-fly analysis methodologies to improve data comprehension; dimensionality reduction and feature selection to reduce execution and transfer times.
Fault-tolerant MPI and checkpointing	Full restart in case of faults creates job requeuing and huge checkpoint data transfers.	Implement malleable job mechanisms to be able to modify the number of required processors at run-time.
Hardware resilient exascale storage demo	The resilience of an application in an exascale system depends on the I/O system; the current I/O interfaces do not consider the type of an I/O operation (e.g. checkpointing vs. other I/O activities)	Overhead for performing checkpoints can be optimized by leveraging non-volatile memory techniques; design I/O software layers and cross-layer data management specialized for resilience, such as checkpointing in memory, hierarchical checkpointing.
Big Data + HPC integrated software stack	Bootleneck in handling numerous files or small I/O requests.	Storage and network I/O aggregation at client side; caching at client side, persistent caching over high-performance storage devices.
Problem-solving environments for large data	PSE are usually not considering data flows or energy efficiency when determining how to execute pipelined tasks.	Optimize the data-flow between the data producers or data consumers inside the PSE.

Such an approach allows one to easily process the tiles at each node in either regular CPUs or in any of the heterogeneous systems available (GPUs, Xeon Phi coprocessors, etc.) using a unified API and runtime that hides the complexity of the underlying process. This abstraction should be supported by abstract data types provided by libraries, so that they can be easily integrated in existing applications.

Another issue is the gap between users with HPC needs and experts with the skills to make the most of these technologies. An appropriate directive-based approach can be to design, implement and evaluate a compiler framework that allows generic translations from high-level languages to exascale heterogeneous platforms. A programming model should be designed at a level that is higher than that of standards, such as OpenCL. The model should enable the rapid development with reduced effort for different heterogeneous platforms. These heterogeneous platforms need to include low energy architectures and mobile devices. The new model should allow a preliminary evaluation of results on the target architectures.

**3.1.3. Energy awareness.** On exascale systems, it becomes impossible to assume that each component of applications will behave exactly the same. To manipulate tasks and components efficiently, different types of information are required. Most of the time, only resource-related information is manipulated.

In exascale systems, energy-related information is of utmost importance. Such information cannot be directly measured at the application level, therefore it must be obtained by using higher-level models of applications. The resource consumption of applications must be tracked during their execution in order to evaluate bottlenecks – when manipulating data-intensive applications these bottlenecks become even more important. Thus resource and energy consumption models need to be temporal. Either during design phase or by runtime-detection, we can model and then predict the resource and energy consumption of each particular component. Reference benchmarks (like the ones from Green Graph 500) allows one to gather feedback leading to improvements in the models.

Using this high level information, a runtime will be able to take informed decisions and thus will reduce energy consumption and prevent bottlenecks.

**3.1.4. Runtime support.** The programming models previously described need to be supported by a runtime system. The runtime system is responsible for managing, coordinating and scheduling the execution of an application by deciding when, where and how its constituent components should be executed.

The execution can be based on data-driven, dynamic DAG scheduling mechanisms, where a component in the DAG will be ready for execution once all of its required input parameters have become available. In this case the runtime system is expected to control and optimize the execution of the applications in an optimized internal representation as a dynamic DAG: the nodes represent computational components and the edges track the data dependencies between components. Once a component is ready to execute, the runtime will choose the potentially best implementation variant, depending on the available hardware resources, the estimated performance, energy and efficiency aspects, the dynamic feedback of the program and system behavior, and the user-specified optimization goals.

Such a runtime can be a rule-based system with event-condition actions. The event specifies the rule that is triggered after which the condition part is queried to see the best suites on which the application should run. When particular conditions are met, the rule fires and the appropriate actions are executed. There are several advantages to this method compared to encoding such rules into an application code. Firstly the rules are organized into a knowledge base which makes them more modular and expendable. It also improves maintenance and a knowledge base is well suited for analysis and optimization of the rules it contains. Lastly an embedded rule-base is much more specific to a certain type of reactive behavior and in our scenario the rule-base is a much more generic mechanism.

In addition, extreme data applications often involve dynamic workflows that demand a changing amount of resources. Moreover, exascale systems aggregate a very large number of computational resources with a high rate of variation in their availability and load state. Thus, applications should be able to dynamically adapt to these changing conditions. Nowadays, many parallel applications are written using the traditional MPI programming paradigm. However, MPI does not provide explicit support for malleability. Thus, MPI should be extended with libraries and run-time support to implement malleable applications. The solution can be based on checkpointing and be implemented at the application-level to improve portability and efficiency. Two different solutions can be explored. First, a virtual malleable approach, where the number of processes



is preserved and the application adapts to changes in the amount of resources by oversubscribing processors. As the number of processes is preserved, this solution has no restrictions on the type of applications allowed. Second, a scalable data redistribution approach to achieve an efficient reconfiguration of the number of processes. An incremental procedure can be followed in this case having as starting point regular data distributions and iterative applications, and extending the application's field in every new step.

### 3.2. Build new tools for monitoring and data-analysis for extreme data applications.

**3.2.1. Extreme data mining techniques.** A novel set of mechanisms and resources needs to be integrated into high-level operations and tools. These should be provided to programmers or data mining researchers for developing, configuring, and running data mining applications targeting at reaching the exascale. The novel set of operations and resources needed to address the areas of accessing, exchanging, transforming, and mining big data sets. The high-level operations should allow a user to compose the novel exascale programming mechanisms in order to access, filter, pre-process, and mine data in parallel using data analysis graphs that correspond to scalable data mining applications. These scalable tools based on novel programming paradigms should be used to design scalable codes that support the implementation of large-scale data mining applications.

Dimensionality reduction of exascale data is an important consideration which can help make near real-time analysis possible by reducing the size of the data necessary for analysis tasks thus reducing computational and ultimately energy requirements.

Another important consideration is that high data throughput is prone to errors. These errors are detrimental to any data mining application or algorithm, thus a method to detect anomalies or outliers in the incoming data needs to be investigated.

**3.2.2. Extreme data collection and monitoring.** Instrumentation, monitoring and measurement techniques should be tuned for data-intensive applications in order to provide fine-granular performance and energy information with low-overhead at the exascale level. Scalable, low overhead measurement and analysis techniques should enable trade-offs between measurement perturbation, measurement data accuracy, analysis response time and overall benefit. An analysis of such techniques should be based on lightweight messages between measurement/analysis threads and the run-time system that selectively applies tracing, profiling or sampling to measure individual non-functional parameters (NFP) for different parts of the application or computing system to control measurement accuracy and program perturbation. To achieve this, an investigation can be done on upgrading options based on techniques such as the Erlang component isolation [1] or subgraph folding algorithms [80]. For collecting measurements, statically and dynamically instrumentation is needed for the dynamic code representation in the run-time system.

To deal with missing data (e.g., energy measurements not available on a code region basis) or for compressing it, analysis techniques based on Hoeffding Tree, adaptive Bayes, classification, and frequent pattern algorithms (i.e., to find memory usage patterns that require less storage compared to simple, time-sampled data) should be investigated. The estimation of NFPs can be exploited for specific architecture parts and application components or regions with incomplete measurements based on sophisticated event processing and analysis patterns (e.g. analyse correlation between execution time and energy consumption) applied to different parallel patterns.

Scalable event processing analysis techniques should allow performance experts to spend their time on developing reusable patterns for NFPs and detecting performance problems, rather than on specific performance analysis features that are hardly reusable for new parallel applications and architectures. The necessary storage infrastructure need to be investigated to address the concurrency needs of monitoring and event processing at large scale. According to the requirements of the implemented operators, memory and disk resources need to support real-time processing and historical data access at low cost.

Existing energy monitoring software is based on specific acquisition devices or performance counters and no standard exists on how to energy profile a HPC application. Standard metrics and profile grain has to be defined, which depends on the capabilities of each power metering device. The different types of energy metering devices available should be identified and a common interface for energy metering needs of exascale HPC should be proposed. The automatic discovery of the necessary libraries and available devices at runtime should be a mandatory feature in this context.

**3.2.3. Scalable data analysis.** Existing performance analysis tools are instruction-centric and offer a code region-based profile of the application. Thus they may hide important sources of bottlenecks related, for example, to an inefficient data distribution or to some misaligned memory addresses causing false sharing. This problem is caused by the focus on processing rather than locality which is a central reason for performance problems in contemporary parallel architectures. A data-centric analysis tool should be therefore designed (in addition to the classical region-based view) exposing the complete global application address space and associating the collected metrics with program variables rather than instructions and code regions. The key insight behind such an approach is that a source of a bottleneck in a HPC application is often not the affected code fragment where it is detected (i.e. where the data is processed with a high communication or thrashing overhead), but where it is allocated. The tool can drive and filter the required instrumentation and data collection described before required for the analysis. The analysis and visualization requirements will be supported by the necessary storage facility with schema support for the operators of data insertion and retrieval involved.

**3.2.4. Automatized correlation analysis.** Understanding possible correlations between conflicting parameters such as execution time, energy consumption, and efficiency at the exascale level may significantly reduce the search space for extreme data mining or runtime optimization purposes at the exascale level. Therefore, search strategies should be investigated to approximate the set of Pareto-optimal solutions. For this kind of search, techniques such as ranked Pareto dominance, crowding, and other techniques with a proven track record in challenging multicriterial search problems like NSGA-II and PAES can be used. These techniques can be enhanced with theoretical results, for example from elementary landscape theory to reduce the search time.

In order to guide dynamic optimization and reduce the search overhead, performance and energy models associated with components that are automatically generated by the runtime system or by the user are needed. To enable dynamic optimization with minimal overhead, the optimization logic can become an HPC problem, distributed among the otherwise inefficiently used resources in a highly malleable fashion.

### **3.3. Adapt the data management and storage techniques to the extreme scale.**

**3.3.1. Predictive and adaptive data layout strategies.** In the software storage I/O stack of current petaflop machines, data locality is managed independently at various levels such as application, middleware, or file systems, thus, data locality is not exposed or propagated. Understanding the relationship between the different layers of the I/O stack is critical to providing locality-awareness in every layer, which is a key factor for building exascale systems. Therefore strategies and mechanisms required to provide predictive and adaptive data layout strategies need to be investigated. It is needed to advance the best-effort strategies that co-locate computation and data towards predictive techniques implemented in cooperation with the system scheduler. However, in the current state-of-the-art software stack data locality cannot be dynamically controlled on the data path from application to storage. This may cause inefficient accesses due to various factors such as data redundancies, lost optimization opportunities, and unnecessary data reorganization. One way to overcome these limitations is to adopt adaptive data-layout strategies that dynamically adjust their behavior to fit the application and storage data layout.

One of the major problems in exascale I/O is the lack of data distribution strategies that can increase data locality by taking into account application behavior. Current I/O systems are mostly statically configured and cannot provide dynamic features to applications and a methodology for profiling and analyzing data-intensive applications for identifying opportunities for exploiting data locality is needed. Such a methodology should allow the study of the dynamics of data movement and layout throughout the whole data storage I/O path from the back-end storage up to the application in order to understand the requirements for building mechanisms for exposing and exploiting data locality. Then, techniques for providing dynamic configurations of the I/O system can be designed and developed to enhance the whole data life-cycle by reflecting applications I/O patterns, restructuring the I/O stack functionalities, and providing predictive and adaptive data allocation strategies.

**3.3.2. Resilience through cross-layer data management.** A cross-layer data management and strategies for resilience should allow checkpointing in memory, hierarchical checkpointing, and should leverage the data layout checkpointing. To achieve resilience and integrity objects can be replicated in physically separate memory zones using an object-based virtualized data sharing for high performance storage I/O. Using fast memory (RAM, NVRAM, SSD, etc.) at the intermediate storage levels of the hierarchy is instrumental to

providing resilience through replication and checkpointing, while maintaining scalability and energy efficiency. As resilience requires a system-wide approach, a cross-layer mechanism with failure semantics to support the design of resilient techniques and optimizations at different stack layers is needed. This mechanism should provide isolation between global and local storage so that there can be a timely notification and avoidance of failures to ensure data integrity.

Supporting the development of I/O software through cross-layer mechanisms will contribute to: enhancing energy efficiency by reducing the communication through a better exploitation of data locality and layout; improving resilience by providing isolation between global/local storage so that there can be a timely notification and avoidance of failures to ensure data integrity; exploiting data locality and concurrency to hide the latencies, avoid congestion, and identify and bypass failures in an early stage. This development of the I/O software also allows the users to express some key aspect of what they want to do with their data, and lets the users know what happened with the management of their data. This bi-directional path of meta-information will provide better information for optimization and the goal is to express this meta-information in a clear way for developers.

**3.3.3. Storage structures for exascale I/O.** For several years, I/O-intensive HPC has been primarily based on distributed object-based filesystems that separate data from metadata management and allow each client to communicate in parallel directly with multiple storage servers. Exascale I/O raises the throughput and storage capacity requirements by several orders of magnitude, therefore methods that can manage the network and storage resources accordingly are needed. The systems already developed for Big Data analytics are not directly applicable to HPC due to the fine-granularity I/O involved in scientific applications. Another weakness of existing systems is the semantic gap between the application requests and the way they are managed at the block level by the storage backend.

The storage bottlenecks of the well known data-intensive applications should be analyzed when scaling the size of the processed dataset and the generated output, or the frequency of the obtained checkpoints. Approaches to aggregate the I/O requirements at the client need to be identified, as well as methodologies for providing the necessary storage support at the backend. The supported concurrency should be increased through a combination of a simple I/O interface, algorithms for both data and metadata indexing, and methods of heterogeneous device management.

Exascale data processing stresses the storage infrastructure in terms of resource utilization, reliability and performance. Therefore appropriate storage structures that rely on object-based filesystems and scalable datastores are needed. Issues that have to be examined include the degree of replication according to fault-tolerance guarantees, caching at different system components for performance at low cost, and concurrency level for parallel data processing. The proposed solutions can take advantage of the latest advances in storage and hardware technology to provide through extreme parallelism improved data throughput, low latency, and durable storage in HPC application execution – experimental software based on production-grade open-source file/storage/data management systems can be built.

An important aspect in those new exascale I/O management techniques will be avoiding metadata management, because metadata generates almost 70% of the I/O operations in most systems – small control I/O operations – usually on shared data structures, which limits global scalability. The requirements of an efficient and fault tolerant metadata service for exascale I/O need to be analyzed, and generic scalable metadata service to use in the storage structure of exascale I/O systems need to be designed and implemented.

**3.4. Validate the concepts and tools usefulness through extreme data applications.** Extreme data is encountered as input, output or intermediate data in multiple data-intensive applications, in fields such as environmental sciences or dynamic system simulations. Applications in these areas are able to measure the advances in processing data on the three dimensions introduced in Section 1, Volume, Value and Variety. We discuss in what follows some candidates for such validations.

**3.4.1. Earth Observation.** Earth Observation (EO) from satellites produces vast amounts of data and is playing an increasingly important role as a regular and reliable high-quality data source for scientific, public sector and commercial activities. The Landsat archive alone corresponds to more than five million images of the Earth's land surface (roughly 1 petabyte of data). From 2014 onwards, new satellites from Europe, USA,

China, Brazil, and India will each produce in a year as much new data as one Landsat satellite has acquired in ten years. This unprecedented amount of data made available for research and operational use will open new challenges.

For more than two decades, the European space industry has developed remote sensing sensors and launched them on robust platforms to assure regular and near-real-time provision of key parameters for the monitoring of land, ocean, ice and atmosphere. The recent data hiatus from ENVISAT's abrupt end of mission will be overcome with the new Sentinel and Earth Explorer programs operated by ESA and the European Global Monitoring for Environment and Security/Copernicus Program Contributing Missions. The above and third-party missions will be combined with data from the long-term EO archive (e.g. ERS, Envisat), in-situ networks and models. Thus, they will provide routine monitoring capabilities of the environment at a global scale and unprecedented insight into how oceans, atmosphere, land and ice operate and interact as part of an interconnected Earth System.

The expanding operational capability of global monitoring from space opens a unique opportunity to build sustainable platforms that support services exploiting archived or new rich EO data sets. In order to be successful, such platforms must exploit the latest advances in scientific data management. Thus they will offer easy and seamless access to all relevant data repositories, as well as efficient operations (search, retrieval, processing/re-processing, projection, visualization and analysis) to extract and distribute single parameters or combined products on user demand.

The broad range of existing constraints for using satellite Earth observations is related to the ability of EO missions to (i) access and monitor the target areas at the right time, and (ii) extract the needed information from the collected sensor data. When not considering timeliness constraints, the sheer volume of data needed for change analysis presents a huge challenge for the current techniques with respect to accessing and processing very large collections of satellite data. Existing classification algorithms using HPC and extracting features from data gathered by satellites or airplanes scanning the Earth cannot be applied in real time and therefore the data collected from satellites is processed only at request (event based). Recently the scalability of classification algorithms has been improved, while the problem of feeding the HPC systems with the remote sensing data and exploiting the data locality remains open.

With the establishment and maintenance of long-term EO programs (Sentinels, Earth Explorer, Landsat or past ENVISAT mission) it is finally possible to obtain a long and homogeneous time series of satellite imagery. Time-series analysis involves capturing the change of one or more variables over time and providing a rich source of information on the dynamic nature of Earth surface processes for monitoring land-cover change and vegetation-climate dynamics. Using a large set of satellite images that cover the same spatial domain but originate from different satellites at different acquisition times, makes it possible to obtain an extended data series with shorter time intervals. This capability will offer new opportunities for monitoring landscape changes and advance our understanding of the reasons behind those changes. Different sensors will support different spatial resolution and registration constraints. When the generated data is integrated in a common model will result in a valuable information source revealing complex patterns for environmental monitoring and analysis of landscape dynamics.

Analyzing big temporal datasets of satellite imagery and derived products qualifies as processing of extreme data. An example is the mining of temporal patterns on the geospatial domain through a composition of services that discover, access and analyze geospatial data cubes in an exascale environment (storages, metadata services, data, analysis tools, etc.) that connects to existing data infrastructures. In particular such EO extreme-scale application can be applied to measure land-use change over time.

**3.4.2. Weather forecast.** The current weather forecasting systems are reliant on numerical simulations. The achieved accuracy of prediction is sensitive to the accuracy of initial conditions and estimates of the current state of the atmosphere —the accuracy depends on an optimal combination of numerical simulations and observational data. Severe weather events can be very localized (within a few km) and over a short lifetime (a few minutes.) To forecast such phenomena the sensors must be able to send data at a rate of half a minute intervals and simulations should run at a resolution of few hundred meters. However, 2Pflops are estimated to be needed to run 100 simulations for 30s at a 100m resolution, producing 200GB of data at each 30s which must be merged with observational data, producing another 200GB of data in the next 30s [63].

The WRF (Weather Research and Forecasting) Model is a recent mesoscale numerical weather prediction system designed to serve both atmospheric research and operational forecasting needs [66]. It features two dynamical cores, a data assimilation system, and a software architecture facilitating parallel computation and system extensibility. WRF is in operational use at US National Centers for Environmental Prediction, Air Force Weather Agency and other centers. Currently the WRF implementations suffer from lack of accuracy and real-time response even though they run on a cluster level. To improve the quality of output and build effective warning system, data collected in real time from various sources should feed into the WRF simulator and the resolution should be increased (resulting in both computation and data-intensive challenges.) The forecasting application needs to be reprogrammed for efficiently handling the increased data requirements based on project developments in exascale programming, monitoring and storage.

Extreme data processing arises in advanced weather forecasting that is based on the effects of heat fluxes and wave height in the sea surface under consideration of hydrological models, and the sensitivity to various convective parameterization schemes of extreme precipitation events over a complex terrain. The future plans of weather forecasting and a related early-warning systems can include an extension to existing processes in space and time to cover parts of a continent at an increased vertical resolution and multiple runs per day [8, 16, 54]. Such a redesign of the forecast process can increase the volume of the output results by approximately 700 times, which will approach 1 Terabyte per day.

**3.4.3. Urban computing.** Urban computing refers to the process of acquisition, integration, and analysis of big and heterogeneous data. The data is generated by a diversity of sources in urban spaces, such as sensors, devices, vehicles, buildings, and human. The goal is to tackle the major issues that cities face, such as air pollution, increased energy consumption and traffic congestion [105]. It involves sensing technologies, advanced data management and analytics models, as well as visualization methods in order to generate solutions that improve urban environment, human life quality, city operation systems. HPC capabilities were recently introduced to develop solutions for sustainable urban operations [92, 46]. The discovery of mobility models is one of the most challenging issues which requires HPC [70], but it can improve resource furnishing and management of cities.

The category of extreme-scale applications includes the smart-cities planning, designed as a composition of different services allowing to gather and collect environmental data, and subsequently process and analyse it in order to mine social and urban behaviors. The involved components in an exascale environment (e.g. storages, metadata services and analysis tools) should interoperate and cooperate seamlessly. The access to underlying infrastructure should be secure, pervasive and ubiquitous. A trajectory pattern-extraction methodology will be applied to a real-world dataset concerning mobility of citizens within an urban area. The goal is to discover user behavior and provide useful information about mobility-related phenomena so as predict future movements of citizens, in order to support decisions in various ways.

We plan to analyze the mobility of citizens in order to discover people and community behaviour, i.e., patterns, rules and regularities in moving trajectories. A novel methodology is needed to extract and analyze the time- and geo-references associated with social data so as to mine interesting locations and frequent travel sequences among these locations in a given geo-spatial region. It will allow to infer human dynamics and behavior within urban context. The extreme amount of geo-tagged data generated also by social-media users together with the data-intensive computations needed for their analysis requires an extreme-scale distributed implementation in which memory size and I/O capabilities scale with compute power.

**3.4.4. Numerical simulations.** Large-scale numerical simulations of complex domains, modeled by partial differential equations (PDEs), comprise processing of data from billions of discretization nodes. For each node, several hundred bytes of data are stored for several thousand time steps of the simulation, creating simulation results in order of Petabytes. This data is then post-processed, analyzed and visualized, creating a new bottleneck in both data-movement and processing phases. Consequently, the scalability preservation in exascale systems requires new algorithms and data structures supported by approaches of efficient communication, data manipulation, storage principles and tailored high-performance processing.

Many of the established numerical algorithms and approaches have been designed at a time when computer platforms were based on a moderate number of very fast computing nodes. In the exascale era, new computing architectures are foreseen, built from millions of cores and equipped with accelerators able to implement data flow

approaches. The existing numerical methodologies and algorithms must follow these trends. For example, an implicit methodology is often preferred for the solution of PDEs because of longer possible time steps, however, because of the additional price for the solution of a large global linear system. An alternative approach, based on explicit methods, requires only a matrix-vector multiplication in each time step. Even though the number of time steps in explicit methods could be higher, such an approach could better fit the new architecture with many smaller processing units resulting in a more efficient methodology.

One of the most complex fields of scientific computing is the computational fluid dynamics (CFD), which is of great interest among researchers and engineers in many areas of science and technology. The core problem is the solution of the Navier-Stokes PDE equation or its variants, e.g., Darcy or Brinkman equation for flow in porous media. The CFD plays a crucial role in the modeling of many important industrial processes, e.g., heat transport-energy studies, solidification of advanced materials, microfluidics and nanofluidics, vehicles design, etc. The solution approaches that are based on local information from neighboring discretization nodes will be preferred in exascale CFD solvers, because such methodologies are closer to natural behavior. Moreover, such approaches are tailored to the execution on exascale computer architectures that incorporate multi-level processor and memory hierarchies, processing accelerators, and high-radix interconnection networks.

Solving extensive problems via local numerical methods requires efficient subdivision of the domain into several million to several billion discretization nodes. Each simulation works on Terabytes of data, but even more data is stored for each simulation in form of checkpointing and simulation results. Each node produces its own simulation data that can create substantial overhead if it has to be communicated to a centralized storage. Distributed storage in which nodes store data locally, or at least at a nearby storage location is preferable to centralized storage at a single location that becomes an interconnection and storage bottleneck. Furthermore, distributed storage of results promotes distributed analysis and data visualization, which also proves highly problematic when working with Terabytes and Petabytes of data. Therefore, the data storage of the simulation procedure should be planned with consideration of the optimal storage locations required.

**3.5. Overview of the proposed methodology.** Tables 3.1 and 3.2 summarize the proposed actions which were discussed in details in the previous subsections. In a concise way, they show the key actions to be carried out and the expected validations coming from some applications domains.

**4. Conclusions.** We provided in this paper a roadmap to reach the extreme-scale level in data processing. It is based on four pillars: new programming and energy models for extreme data applications, new tools for monitoring and data-analysis for extreme data applications, adaptation of data management and storage techniques to extreme scale, and validation of the concepts and tools through specific extreme data applications. For each topic some limitations of the existing concepts and technologies have been identified and potential solutions to overcome these limitations were sketched without claiming that they guarantee the success or that they are the only solution. We recognize that the efforts to implement these solutions can be enormous and will require the joint efforts of multiple teams. Therefore we considered it useful to expose our ideas and proposals in this paper and to seek for contributions in the proposed directions in the years to come.

## REFERENCES

- [1] J. ARMSTRONG, *Erlang*, Communications of ACM, 53(9), September 2010.
- [2] A. ACOSTA, F. ALMEIDA, *Towards a Unified Heterogeneous Development Model in AndroidTM*, Euro-Par 2013, 238-248
- [3] I. AHMAD, A. ABDULAH, A. ALGHAMDI, *Towards the Designing of a Robust Intrusion Detection System through an Optimized Advancement of Neural Networks*, Advances in Comp. Science and IT, Springer 2010.
- [4] M. GALEA, M. ATKINSON, C. S. LIEW, P. MARTIN, *Final Report on the ADMIRE Architecture*. 2011
- [5] E. ALPAYDIN, *Introduction to machine learning*. The MIT Press, 2004.
- [6] J. ARNOLD, *Software Defined Storage with OpenStack Swift*, Amazon, 2013.
- [7] A. BARAK, T. BEN-NUN, E. LEVY A. SHILOH, *A package for OpenCL based heterogeneous computing on clusters with many GPU devices*, 2010 IEEE Intl. Conf. on Cluster Computing Workshops and Posters, 17, 2010
- [8] A. BARTZOKAS, V. KOTRONI, K. LAGOUVARDOS, C.J. LOLIS, A. GKIKAS, M.I. TSIROGIANNI, *Weather forecast in north-western Greece: RISKMED warnings and verification of MM5 model*, Natural Hazards and Earth System Sciences, 10, 383-394, 2010.
- [9] A. BOURDON, A. NOUREDDINE, R. ROUYOY, L. SEINTURIER, *Powerapi: A software library to monitor the energy consumed at the process level*, ERCIM News 2013, no. 92.

Table 3.1: Actions of the proposed methodology

Category	Actions
Programming paradigms and models	Design a simple and scalable programming model based on basic operations for data intensive/data-driven applications to deal with the use of a massive amount of processing elements; develop an API based on that model which includes operations for data access, data communication and data processing on groups of cores; interoperability and integration with the MapReduce and MPI models.
Productive exascale heterogeneity exploitation	Different data-centric abstractions integrated to provide a unified programming model and API that allows the productive programming of both heterogeneous and distributed memory systems; large scale data-parallelism can be exploited on top of the abstraction of n-dimensional arrays subdivided in tiles; directive-based approach and a compiler framework that allows generic translations from high-level languages to exascale heterogeneous platforms.
Energy awareness	Model and predict the resource and energy consumption of data-intensive tasks.
Runtime support	Execution based on data-driven via dynamic DAG scheduling mechanisms; rule-based system with event-condition actions; MPI extended with libraries and run-time support to implement malleable applications.
Extreme data mining techniques	Novel set of operations needed to address the areas of accessing, exchanging, transforming, and mining big data sets; access, filter, pre-process, and mine data in parallel using data analysis graphs; dimensionality reduction techniques for exascale data; methods to detect anomalies or outliers in extreme data.
Extreme data collection and monitoring	Instrumentation, monitoring and measurement techniques tuned for data-intensive applications; support real-time processing and historical data access at low cost; common interface for energy metering needs of exascale data processing.
Scalable data analysis	Data-centric analysis tool; analysis and visualization requirements supported by the storage facility with schema support for the operators of data insertion and retrieval involved.
Automatized correlation analysis	Understanding possible correlations between conflicting parameters using parallel search strategies.
Predictive and adaptive data layout strategies	Advance the best-effort strategies that co-locate computation and data towards predictive techniques implemented in cooperation with the system scheduler; methodology for profiling and analyzing data-intensive applications for identifying opportunities for exploiting data locality.
Resilience through cross-layer management	Mechanisms for checkpointing in memory, hierarchical checkpointing, and data layout checkpointing; provide isolation between global and local storage.
Storage structures for exascale I/O	Approaches to aggregate the I/O requirements at the client; storage structures that rely on object-based filesystems and scalable datastores; efficient and fault tolerant metadata service for exascale I/O.

- [10] J. B. BUCK, N. WATKINS, J. LEFEVRE, K. IOANNIDOU, C. MALTZAHN, N. POLYZOTIS, S. BRANDT, *SciHadoop: Array-based Query Processing in Hadoop*, ACM Intl Conf for High Performance Computing, Networking, Storage and Analysis (SC), 2011.
- [11] J. BUISSON, O. SONMEZ, H. MOHAMED, W. LAMMERS, D. EPEMA, *Scheduling malleable applications in multicluster systems*, IEEE International Conference on Cluster Computing, 372381, 2007.
- [12] L. C. CANON AND E. EMMANUEL, *MO-Greedy: an Extended Beam-Search Approach for Solving a Multi-Criteria Scheduling Problem on Heterogeneous Machines*, International Symposium on Parallel and Distributed Processing, Workshops and Phd Forum, Shanghai, 2011.
- [13] P. CARNS, K. HARMS, W. ALLCOCK, C. BACON, S. LANG, R. LATHAM, R. ROSS, *Understanding and Improving Computational Science Storage Access through Continuous Characterization*, ACM Transactions on Storage (TOS), vol 7, no 3, 2011.
- [14] M. CERA, Y. GEORGIU, O. RICHARD, N. MAILLARD, P. NAVAUX, *Supporting Malleability in Parallel Architectures with Dynamic CPUSets Mapping and Dynamic MPI*, Distributed Computing and Networking, 242257. Springer, 2010.
- [15] G. CHANDRASHEKAR, F. SAHIN, *A survey on feature selection methods*, Computers & Electrical Engineering, Volume 40, Issue 1, 16-28, 2014.
- [16] F. CHEN, J. DUDHIA, *Coupling an advanced land surface-hydrology model with the Penn State-NCAR MM5 modeling system. Part I: Model implementation and sensitivity*, Mon. Wea. Rev., 129, 569-585, 2001

Table 3.2: Expected validations of the proposed actions by the selected applications

Category	Earth observation	Weather forecast	Urban computing	Numerical simulations
Programming paradigms and models	✓	✓	✓	✓
Productive exascale heterogeneity exploitation	✓			✓
Energy awareness		✓		
Runtime support	✓		✓	✓
Extreme data mining techniques	✓		✓	
Extreme data collection and monitoring		✓		
Scalable data analysis	✓	✓	✓	
Automatized correlation analysis		✓		
Predictive and adaptive data layout strategies	✓			✓
Resilience through cross-layer management		✓		✓
Storage structures for exascale I/O	✓	✓		

- [17] Z. CHEN, Y.F. LI, *Anomaly Detection Based on Enhanced DBScan Algorithm*, Procedia Engineering, 2011.
- [18] S. CONWAY, C. DEKATE, E. JOSEPH, *IDC HPC End-User Special Study of High-Performance Data Analysis (HPDA): Where Big Data Meets HPC*, Worldwide Study of HPC End-User Sites, 2013, [www.idc.com](http://www.idc.com)
- [19] L. F. CUPERTINO, G. DA COSTA, J.-M. PIERSON, *Towards a generic power estimator*, Computer Science - Research and Development, Springer Berlin / Heidelberg, Special Issue Ena-HPC 2014
- [20] P. MARTIN, G. YAIKHOM, *DISPEL: Users' Manual*, 2011, <http://www.admire-project.eu/docs/DISPEL-manual.pdf>
- [21] R. F. VICENTE, I. KLAMPANOS, A. KRAUSE, M. DAVID, A. MORENO, M. ATKINSON, *dispel4py: A Python Framework for Data-Intensive Scientific Computing*, 2014 Data Intensive Scalable Computing Systems (DISCS-2014) workshop (SC14).2014
- [22] J. DEAN AND S. GHEMAWAT, *Mapreduce: simplified data processing on large clusters*, Commun. ACM, 51(1):107113, 2008.
- [23] DEPARTMENT OF ENERGY, *Cross-cutting Technologies for Computing at the Exascale*, Washington, DC, Scientific Grand Challenges Workshop Series, pp. 99, 2009. <http://extremecomputing.labworks.org/crosscut/CrosscutWSFinalReptDraft02.pdf>.
- [24] DEPARTMENT OF ENERGY, *DOE Exascale Roadmap Highlights Big Data*, 2014, <http://www.hpcwire.com/2014/04/07/doe-exascale-roadmap-highlights-big-data/>
- [25] J. DONGARRA, P. BECKMAN, T. MOORE, P. AERTS ET AL, *The International Exascale Software Project roadmap*, International J. of High Performance Computing Applications, 2011.
- [26] D. ENGEL, L. HUTTENBERGER, B. HAMANN, *A Survey of Dimension Reduction Methods for High-Dimensional Data Analysis and Visualization*, Visualization of Large and Unstructured Data Sets: Applications in Geospatial Planning, Modeling and Engineering - Proceedings of IRTG Workshop, 2011
- [27] M. ESHEL, R. HASKIN, D. HILDEBRAND, M. NAIK, F. SCHMUCK, R. TEWARI, *Panache: A Parallel File System Cache for Global File Access*, FAST 2010. Usenix., 2010.
- [28] EUROPEAN TECHNOLOGY PLATFORM FOR HIGH PERFORMANCE COMPUTING, *ETP4HPC Strategic Research Agenda Achieving HPC leadership in Europe*, Barcelona May 2013, [www.etp4hpc.eu](http://www.etp4hpc.eu).
- [29] EUROPEAN TECHNOLOGICAL PLATFORM FOR HIGH PERFORMANCE COMPUTING, *Vision Paper*, 2012
- [30] M.J. FLYNN, O. MENCER, V. MILUTINOVIĆ, G. RAKOČEVIĆ, P. STENSTROM, R. TROBEC, M. VALERO, *Moving from petaflops to petadata*, Communications of the ACM. 2013;56:39-42;
- [31] M.M. GABER, A. ZASLAVSKY, S. KRISHNASWAMY, *Mining data streams: a review*, ACM Sigmod Record, volume 34, number 2, 18-26, ACM, 2005.
- [32] T. GAMBLIN, B.R. DE SUPINSKI, M. SCHULZ, R. FOWLER, D.A. REED, *Clustering performance data efficiently at massive scales*, 24th ACM International Conference on Supercomputing, 243-252, ACM, 2010.
- [33] C. GEORGE, S. S. VADHIYAR, *ADFT: An adaptive framework for fault tolerance on large scale systems using application malleability*, Procedia Computer Science 9 (0) (2012) 166-175, Proceedings of the International Conference on Computational Science, ICCSg 2012. doi: 10.1016/j.procs.2012.04.018.
- [34] S. GHEMAWAT, H. GOBIOFF, AND S.-T. LEUNG, *The google file system*, Proceedings of the nineteenth ACM symposium on Operating systems principles, SOSP 03, 2943, ACM, 2003.
- [35] I. GRASSO, S. PELLEGRINI, B. COSENZA, T. FAHRINGER, *LibWater: heterogeneous distributed computing made easy*, ICS 2013: 161-172, 2013
- [36] W. GROPP, M. SNIR, *Programming for Exascale Computers*, Computing in Science & Engineering, vol.15, no. 6, 27-35, 2013.
- [37] HDF GROUP, *HDF5*, <http://www.hdfgroup.org/hdf5/>.
- [38] J. HE, J. BENT, A. TORRES, G. GRIDER, G. GIBSON, C. MALTZAHN, X.-H. SUN, *I/O Acceleration with Pattern Detection*, ACM Symp on High-Performance Parallel and Distributed Computing (HPDC), 2013.
- [39] HIGH PERFORMANCE AND EMBEDDED ARCHITECTURE AND COMPILATION CONSORTIUM, *HiPEAC Roadmap*, 2011, [www.hipeac.net/roadmap](http://www.hipeac.net/roadmap)
- [40] C.-L. HUANG, J.-F. DUN, *A distributed PSOSVM hybrid system with feature selection and parameter optimization*, Applied



- Soft Computing, Vol. 8, Issue 4, 1381-1391, 2008
- [41] J. HUNGERSHOFER, *On the combined scheduling of malleable and rigid jobs*, Proceedings of the 16th Symposium on Computer Architecture and High Performance Computing (SBAC-PAD 2004), 206213, 2004.
- [42] IBM, *GPFS. General Parallel File System, Efficient storage management for big data applications*, <http://www.ibm.com/systems/software/gpfs>.
- [43] H. H. INBARANI, A. T. AZAR, G. JOTHI, *Supervised hybrid feature selection based on PSO and rough sets for medical diagnosis*, Computer Methods and Programs in Biomedicine, Vol. 113, Issue 1, 175-185, 2014.
- [44] F. ISAILA, J. GARCIA, J. CARRETERO, R.B. ROSS, D. KIMPE, *Making the Case for Reforming the I/O Software Stack of Extreme-Scale Systems*, Technical Report. Argonne Labs, IL, USA, 2014.
- [45] F. JEMILI, M. ZAGHDOUD, M. BEN AHMED, *A Framework for an Adaptive Intrusion Detection System using Bayesian Network*, Intelligence and Security Informatics, 2007.
- [46] A. JIMENEZ-MOLINA AND I.-Y. KO, *Spontaneous task composition in urban computing environments based on social, spatial, and temporal aspects*, Eng. Appl. Artif. Intell. 24, 8 2011, 1446-1460.
- [47] MD. M. KABIR, MD. M. ISLAM, K. MURASE, *A new wrapper feature selection approach using neural network*, Neurocomputing, Vol. 73, Issues 1618, 3273-3283, 2010.
- [48] Y. KESSACI, N. MELAB AND E.-G. TALBI, *A multi-start local search heuristic for an energy efficient VMs assignment on top of the OpenNebula Cloud manager*, Future Generation Computer Systems 36, 237-256, 2014.
- [49] A. K. M. KHALED, A. TALUKDER, M. KIRLEY AND R. BUYYA, *Multiobjective differential evolution for scheduling workflow applications on global Grids*, Concurrency and Computation: Practice & Experience, vol. 21, no. 13, 1742-1756, 2009.
- [50] L. KHAN, M. AWAD, B. THURASINGHAM, *A New Intrusion Detection System Using Support Vector Machines and Hierarchical Clustering*, The VLDB Journal, 2007.
- [51] V. R. KHARE, X. YAO AND K. DEB, *Performance Scaling of Multi-Objective Evolutionary Algorithms*, Conference on Evolutionary Multi-Criterion Optimization, 2003.
- [52] KUFBRIN, R. PERFSUITE, *An accessible, open source performance analysis environment for Linux*, 6th International Conference on Linux Clusters: The HPC Revolution, volume 151, p 5, 2005.
- [53] M. KUMAR, M. HANUMANTHAPPA, T. KUMAR, *Intrusion Detection System using decision tree algorithm*, IEEE 14th International Conference on Communication Technology (ICCT), 2012.
- [54] G. KORRES, A. PAPADOPOULOS, P. KATSAFADOS, D. BALLAS, L. PERIVOLIOTIS, K. NITTIS, *A 2-year intercomparison of the WAM-Cycle4 and the WAVEWATCH-III wave models implemented within the Mediterranean Sea*, Mediterranean Marine Science 12(1), 129-152, 2011
- [55] J. LI, W.-K. LIAO, A. CHOUDHARY, R. ROSS, R. THAKUR, W. GROPP, R. LATHAM, A. SIEGEL, B. GALLAGHER, M. ZINGALE, *Parallel netcdf: A high-performance scientific i/o interface*, Proceedings of the 2003 ACM/IEEE conference on Supercomputing, p. 39, ACM, 2003.
- [56] P. LLOPIS, F.J. GARCA-BLAS, F. ISAILA, J. CARRETERO, *VIDAS: Object-based Virtualized Data Sharing for High Performance Storage I/O*, Proceedings of the ACM ScienceCloud'13, 2013.
- [57] G. LLORT, J. GONZALEZ, H. SERVAT, J. GIMENEZ, J. LABARTA, *On-line detection of large-scale parallel application's structure*, 2010 IEEE International Symposium on Parallel & Distributed Processing (IPDPS), p 1-10, 2010
- [58] T.V. LUONG, N. MELAB, E.-G. TALBI, *GPU-Based multi-start local search algorithms*, Learning and Intelligent Optimization. 6683, 321-335. 2011, Springer.
- [59] T.V. LUONG, N. MELAB, E.-G. TALBI, *GPU computing for parallel local search metaheuristic algorithms*, Transactions on Computers 62, 173-185, 2013
- [60] LUSTRE, *High Performance and Scalability*, <http://www.lustre.org>.
- [61] K. EL MAGHRAOUI, T.J. DESELL, B.K. SZYMANSKI, C. A. VARELA, *Malleable iterative MPI applications*, Concurrency Computat.: Pract. Exper., 21(3): 393413, 2009.
- [62] J. MAIR, Z. HUANG, D. EYERS, L. F. CUPERTINO, G. DA COSTA, J.-M. PIERSON, H. HLAVACS, *Power Modeling, Large-Scale Distributed Systems and Energy Efficiency: A holistic view*. Jean-Marc Pierson (Eds.), John Wiley and Sons, 5, March 2015
- [63] S. MATSUOKA, H. SATO, O. TATEBE, M. KOIBUCHI, I. FUJIWARA, S.SUZUKI, ET AL, *Extreme Big Data (EBD): Next Generation Big Data Infrastructure Technologies Towards Yottabyte*, Supercomputing Frontiers and Innovations, vol. 1, no. 2, 2014, 89-107
- [64] N. MELAB, K. BOUFARAS, E.-G. TALBI, ET AL, *ParadisEO-MO-GPU: a framework for parallel GPU-based local search metaheuristics*, Proceeding of the 15th annual conference on Genetic and evolutionary computation conference, 1189-1196. ACM, 2013.
- [65] D. MEY, S. BIERSDORF, C. BISCHOF, K. DIETHELM, D. ESCHWEILER, M. GERNDT, A. KNPFER, D. LORENZ, A. MALONY, W.E. NAGEL, ET AL, *Score-P: A Unified Performance Measurement System for Petascale Applications*, Competence in High Performance Computing 2010, 85-97, Springer, 2012.
- [66] J. MICHALAKES, J. DUDHIA, D. GILL, T. HENDERSON, J. KLEMP, W. SKAMAROCK, W. WANG, *The Weather Research and Forecast Model: Software Architecture and Performance*, 11th ECMWF Workshop on the Use of High Performance Computing In Meteorology, 2004.
- [67] B.P. MILLER, M.D. CALLAGHAN, J.M. CARGILLE, J.K. HOLLINGSWORTH, R.B. IRVIN, K.L. KARAVANIC, K.L., K. KUNCHITHAPADAM, T. NEWHALL, *The Paradyn parallel performance measurement tool*, Computer, vol. 28, no. 11, 37-46, 1995.
- [68] MPI FORUM, *High-end-computing systems*, <http://www.mpi-forum.org/>.
- [69] C. MODI, D. PATEL, B. BORISANIYA, H. PATEL, A. PATEL, M. RAJARAJAN, *A survey of intrusion detection techniques in Cloud*, Journal of Network and Computer Applications, 2013.

- [70] M. NANNI, R. TRASARTI, G. ROSSETTI, D. PEDRESCHI, *Efficient distributed computation of human mobility aggregates through user mobility profiles*, Proceedings of the ACM SIGKDD International Workshop on Urban Computing (Urb-Comp '12), 2012, 87-94.
- [71] J. NIEPLOCHA, B. PALMER, V. TIPPARAJU, M. KRISHNAN, H. TREASE, E. APRA, *Advances, Applications and Performance of the Global Arrays Shared Memory Programming Toolkit*, Intl. J. of High Performance Computing Applications 20(2): 203-23, 2006.
- [72] R.V. VAN NIEUWPOORT, J.W. ROMEIN, *Correlating Radio Astronomy Signals with Many-Core Hardware*, Intl. J. of Parallel Programming 39(1), 88114, 2011.
- [73] R.W. NUMRICH, J. REID, *Co-array Fortran for parallel programming*, ACM SIGPLAN FORTRAN Forum 17(2):131, 1998.
- [74] PLANETHPC, *Strategy for Research and Innovation through HPC*, November 2011, <http://www.planethpc.eu/images/stories/planethpc-strategy2.pdf>
- [75] PARTNERSHIP FOR ADVANCED COMPUTING IN EUROPE, *PRACE Scientific Case 2012-2020*, October 2012, [www.prace-ri.eu/PRACE-The-Scientific-Case-for-HPC](http://www.prace-ri.eu/PRACE-The-Scientific-Case-for-HPC)
- [76] J. E. PECERO, P. BOUVRY, H. J. FRAIRE HUACUJA, S.U. KHAN, *A Multi-objective GRASP Algorithm for Joint Optimization of Energy Consumption and Schedule Length of Precedence-Constrained Applications*, 9th IEEE International Conference on Dependable, Autonomic and Secure Computing, 2011.
- [77] ORANGE, *Orangefs/pvfs*, <http://www.pvfs.org>.
- [78] R CORE TEAM, *R: A Language and Environment for Statistical Computing*, R Foundation for Statistical Computing, Vienna, Austria, 2014
- [79] I.RAICU, I.T. FOSTER, P. BECKMAN, *Making a case for distributed file systems at exascale*, 3rd International workshop on Large-scale system and application performance, LSAP 11, 1118, ACM, 2011.
- [80] P.C. ROTH, B.P. MILLER, *On-line automated performance diagnosis on thousands of processes*, 11th ACM SIGPLAN symposium on Principles and practice of parallel programming, 69-80, ACM, 2006.
- [81] R. REYES, I. LPEZ-RODRGUEZ, J.J. FUMERO, F. DE SANDE, *accULL: An OpenACC Implementation with CUDA and OpenCL Support*, Euro-Par 2012, 871-882, 2012.
- [82] S.S. SHENDE, A.D. MALONY, *The Tau Parallel Performance System*, International Journal of High Performance Computing Applications, vol. 20, no. 2, 287-311, 2006.
- [83] D. SINGH AND R. GARG, *A robust multi-objective optimization to workflow scheduling for dynamic grid*, International Conference on Advances in Computing and Artificial Intelligence, 183-188, 2011.
- [84] M. SNIR, R.W. WISNIEWSKI, J.A. ABRAHAM, S.V. ADVE, S. BAGCHI ET AL, *Addressing Failures in Exascale Computing*, Tech. Report ANL/MCS-TM-332, Argonne Nat'l Laboratory, Mathematics and Computer Science Division, Apr. 2013.
- [85] R. HILL, *SPRINT: A new parallel framework for R*, BMC Bioinformatics. 2008
- [86] R. SUDARSAN, C. J. RIBBENS, *ReSHAPE: A Framework for Dynamic Resizing and Scheduling of Homogeneous Applications in a Parallel Environment*, International Conference on Parallel Processing, ICPP 2007, 44-44, 2007.
- [87] C. SWEETLIN HEMALATHA, V. VAIDEHI, R. LAKSHMI, *Minimal infrequent pattern based approach for mining outliers in data streams*, Expert Systems with Applications, on-line October 2014
- [88] I. SYARIF, A. PRUGEL-BENNETT, G. WILLS, *Unsupervised Clustering Approach for Network Anomaly Detection*, Networked Digital Technologies, Springer 2012.
- [89] A. K. A. TALUKDER, M. KIRLEY, R. BUYYA, *Multiobjective Differential Evolution for Workflow Execution on Grids*, 5th International Workshop on Middleware for Grid Computing, California, 2007.
- [90] C. J. TAN, C.P. LIM, Y.N CHEAH, *A multi-objective evolutionary algorithm-based ensemble optimizer for feature selection and classification with neural network models*, Neurocomputing, Vol. 125, 217-228, 2014.
- [91] W. TANTISIROJ, S. PATIL, G. GIBSON, S. W. SON, S. J. LANG, R. B. ROSS, *On the Duality of Data-intensive File System Design: Reconciling HDFS and PVFS*, ACM Intl Conf for High Performance Computing, Networking, Storage and Analysis (SC), 2011.
- [92] A. TENSCHERT, M. ASSEL, A. CHEPTSOV, G. GALLIZO, E.D. VALLE, I. CELINO, *Parallelization and Distribution Techniques for Ontology Matching in Urban Computing Environments*, Proceedings of OM 2009.
- [93] C. TSOTSKAS, T. KIPOUROS, A.M. SAVILL, *The Design and Implementation of a GPU-enabled Multi-objective Tabu-search Intended for Real World and High-dimensional Applications*, Procedia Computer Science, Vol. 29, 2152-2161, 2014.
- [94] D. TALIA, P. TRUNFIO, O. VERTA, *The Weka4WS Framework for Distributed Data Mining in Service-oriented Grids*, Concurrency and Computation: Practice and Experience. 20(16): 1933-1951, 2008
- [95] UPC CONSORTIUM, *UPC language specifications v1.2*, 2005.
- [96] VERCE CONSORTIUM, *VERCE*, <http://www.verce.eu/>
- [97] M.VIÑAS, Z. BOZKUS, B.B. FRAGUELA, *Exploiting heterogeneous parallelism with the Heterogeneous Programming Library*, J. Parallel Distrib. Comput. 73(12): 1627-1638, 2013.
- [98] M. WACHS, M. ABD-EL-MALEK, E. THERESKA, G. R. GANGER, *Argon: performance insulation for shared storage servers*, USENIX Conf. on File and Storage Technologies (FAST), 61-76, 2007.
- [99] M. HALL, E. FRANK, G. HOLMES, B. PFAHRINGER, P. REUTEMANN, I. H. WITTEN, *The WEKA Data Mining Software: An Update*, SIGKDD Explorations, Volume 11, Issue 1. 2009
- [100] X. WANG, R. BUYYA AND J. SU, *Reliability-Oriented Genetic Algorithm for Workflow Applications using Max-Min Strategy*, 9th International Symposium on Cluster Computing and the Grid, 2009.
- [101] H. XIA, J. ZHUANG, D. YU, *Multi-objective unsupervised feature selection algorithm utilizing redundancy measure and negative epsilon-dominance for fault diagnosis*, Neurocomputing, Vol. 146, 113-124, 2014.
- [102] H. YOON, C.-S. PARK, J. S. KIM, J.-G. BAEK, *Algorithm learning based neural network integrating feature selection and classification*, Expert Systems with Applications, Vol. 40, Issue 1, 231-241, 2013.

- [103] H. YU, R. CHEN, G. ZHANG, *A SVM Stock Selection Model within PCA*, *Procedia Computer Science*, Vol. 31, 406-412, 2014.
- [104] J. YU, M. KIRLEY AND R. BUYYA, *Multi-Objective Planning for Workflow Execution on Grids*, 8th International Conference on Grid Computing, 2007.
- [105] YU ZHENG, LICIA CAPRA, OURI WOLFSON, HAI YANG, *Urban Computing: concepts, methodologies, and applications*, *ACM Transaction on Intelligent Systems and Technology (ACM TIST)*. 2014
- [106] T. ZHU, A. TUMANOV, M. A. KOZUCH, M. HARCHOL-BALTER, G. R. GANGER, *PriorityMeister: Tail Latency QoS for Shared Networked Storage*, *ACM Symp. Cloud Computing (SoCC)*, 2014.

*Edited by:* Viorel Negru

*Received:* December 16, 2015

*Accepted:* January 16, 2016



---

## AIMS AND SCOPE

The area of scalable computing has matured and reached a point where new issues and trends require a professional forum. SCPE will provide this avenue by publishing original refereed papers that address the present as well as the future of parallel and distributed computing. The journal will focus on algorithm development, implementation and execution on real-world parallel architectures, and application of parallel and distributed computing to the solution of real-life problems. Of particular interest are:

**Expressiveness:**

- high level languages,
- object oriented techniques,
- compiler technology for parallel computing,
- implementation techniques and their efficiency.

**System engineering:**

- programming environments,
- debugging tools,
- software libraries.

**Performance:**

- performance measurement: metrics, evaluation, visualization,
- performance improvement: resource allocation and scheduling, I/O, network throughput.

**Applications:**

- database,
- control systems,
- embedded systems,
- fault tolerance,
- industrial and business,
- real-time,
- scientific computing,
- visualization.

**Future:**

- limitations of current approaches,
- engineering trends and their consequences,
- novel parallel architectures.

Taking into account the extremely rapid pace of changes in the field SCPE is committed to fast turnaround of papers and a short publication time of accepted papers.

---

## INSTRUCTIONS FOR CONTRIBUTORS

Proposals of Special Issues should be submitted to the editor-in-chief.

The language of the journal is English. SCPE publishes three categories of papers: overview papers, research papers and short communications. Electronic submissions are preferred. Overview papers and short communications should be submitted to the editor-in-chief. Research papers should be submitted to the editor whose research interests match the subject of the paper most closely. The list of editors' research interests can be found at the journal WWW site (<http://www.scpe.org>). Each paper appropriate to the journal will be refereed by a minimum of two referees.

There is no a priori limit on the length of overview papers. Research papers should be limited to approximately 20 pages, while short communications should not exceed 5 pages. A 50–100 word abstract should be included.

Upon acceptance the authors will be asked to transfer copyright of the article to the publisher. The authors will be required to prepare the text in  $\text{\LaTeX} 2_{\epsilon}$  using the journal document class file (based on the SIAM's `siamltex.clo` document class, available at the journal WWW site). Figures must be prepared in encapsulated PostScript and appropriately incorporated into the text. The bibliography should be formatted using the SIAM convention. Detailed instructions for the Authors are available on the SCPE WWW site at <http://www.scpe.org>.

Contributions are accepted for review on the understanding that the same work has not been published and that it is not being considered for publication elsewhere. Technical reports can be submitted. Substantially revised versions of papers published in not easily accessible conference proceedings can also be submitted. The editor-in-chief should be notified at the time of submission and the author is responsible for obtaining the necessary copyright releases for all copyrighted material.